

**PYTHAGOREAN FUZZY SETS, ROUGH PYTHAGOREAN
FUZZY SETS, AND PYTHAGOREAN FUZZY SOFT SETS
IN UP (BCC)-ALGEBRAS**

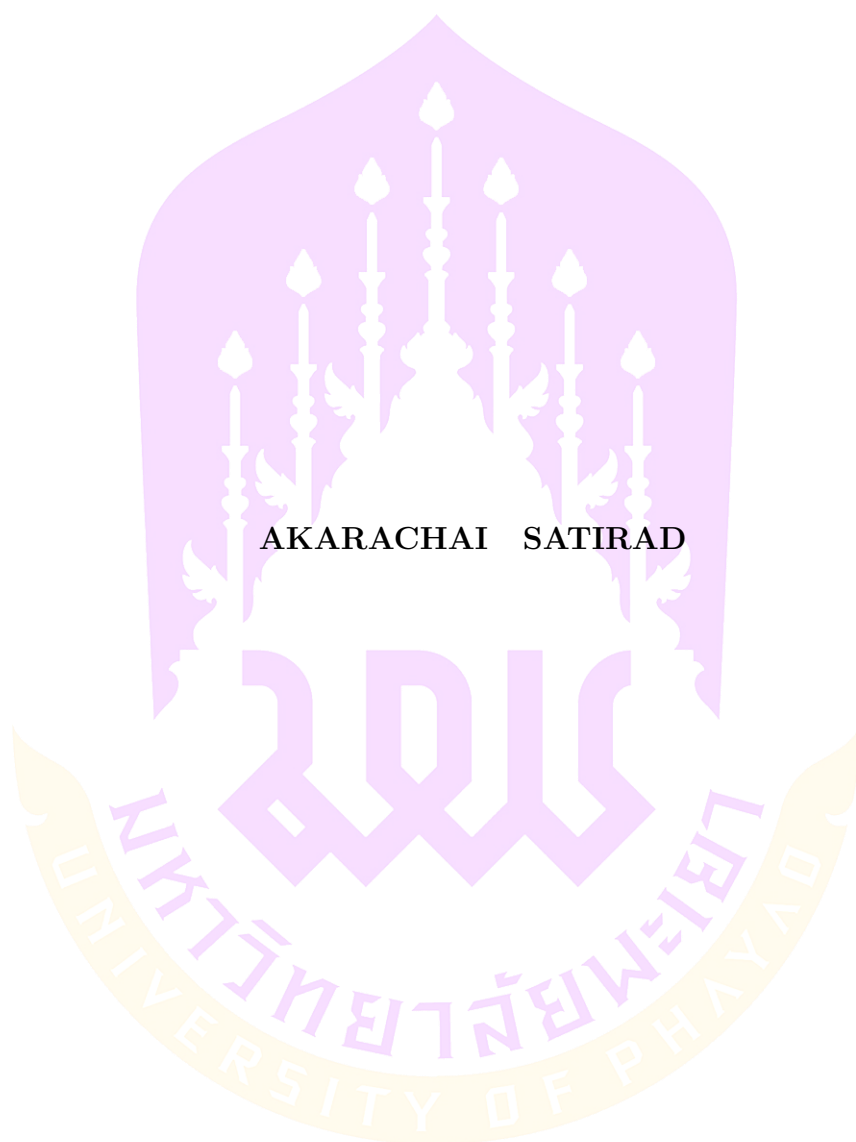

AKARACHAI SATIRAD

**A Dissertation Submitted to University of Phayao
in Partial Fulfillment of the Requirements
for the Doctor of Philosophy in Mathematics
March 2023**

Copyright 2023 by University of Phayao

Dissertation

Title

Pythagorean Fuzzy Sets, Rough Pythagorean Fuzzy Sets, and Pythagorean
Fuzzy Soft Sets in UP (BCC)-Algebras

Submitted by Akarachai Satirad

Approved in partial fulfillment of the requirements for the
Doctor of Philosophy in Mathematics
University of Phayao

Ronnason ChinramChairman

(Associate Professor Dr. Ronnason Chinram)

P. J. JulathaCommittee

(Acting Sub Lieutenant Dr. Pongpun Julatha)

A. IampanCommittee

(Associate Professor Dr. Aiyared Iampan)

Tanakit ThianwanCommittee

(Associate Professor Dr. Tanakit Thianwan)

W. CholanjiakCommittee

(Associate Professor Dr. Watcharaporn Cholanjiak)

D. YambangwaiCommittee

(Associate Professor Dr. Damrongsak Yambangwai)

Approved by

.....

(Associate Professor Dr. Chayan Boonyarak)

Dean of School of Science

March 2023

ACKNOWLEDGEMENT

First of all, I would like to express my sincere appreciation to my supervisor, Associate Professor Dr. Aiyared Iampan, for the continuous support of my Ph.D. study and related research; his primary idea, guidance and motivation enabled me to carry out my study successfully.

I gladly thank the supreme committees, Associate Professor Dr. Ronnason Chinram and Acting Sub Lieutenant Dr. Pongpun Julatha and the committees, Associate Professor Dr. Tanakit Thianwan, Associate Professor Dr. Watcharaporn Cholamjiak, and Associate Professor Dr. Damrongsak Yambangwai for recommendation about my presentation, report and future works.

I also thank all of my teachers for their previous valuable lectures that give me more knowledge during my study at the Department of Mathematics, School of Science, University of Phayao.

I appreciate the mention that my graduate study was financially supported by the National Research Council of Thailand (NRCT).

Finally, my graduation would not be achieved without the best wishes from my parents, who help me with everything and always gives me the greatest love, willpower and financial support until this study completion.

Akarachai Satirad

เรื่อง: เขตวิภันชัยพิทาโกเรียน เขตวิภันชัยพิทาโกเรียนหยาบ และเขตอ่อนวิภันชัยพิทาโกเรียนในพิชคณิตยูพี (ปีซีซี)

ผู้วิจัย: อัครชัย สติราชกูร์, ดุษฎีนิพนธ์: ปร.ด. (คณิตศาสตร์), มหาวิทยาลัยพะเยา, 2566

ประธานที่ปรึกษา: รองศาสตราจารย์ ดร.อัยเรศ เอี่ยมพันธ์

กรรมการที่ปรึกษา: รองศาสตราจารย์ ดร.ธนกฤต เทียนหวาน, รองศาสตราจารย์ ดร.วัชรภรณ์ ซอล้ำเจียก

คำสำคัญ: พิชคณิตยูพี, พิชคณิตปีซีซี, เขตวิภันชัยพิทาโกเรียน, เขตวิภันชัยพิทาโกเรียนหยาบ, เขตอ่อนวิภันชัยพิทาโกเรียน

บทคัดย่อ

เริ่มต้น เราประยุกต์แนวคิดของเขตวิภันชัยพิทาโกเรียนไปยังพิชคณิตยูพี (ปีซีซี) และแนะนำเขตวิภันชัยพิทาโกเรียนในพิชคณิตยูพี (ปีซีซี) 8 ชนิด โดยให้ชื่อว่า พิชคณิตย่อยยูพี (ปีซีซี) วิภันชัยพิทาโกเรียน ตัวกรองยูพี (ปีซีซี) ไกลวิภันชัยพิทาโกเรียน ตัวกรองยูพี (ปีซีซี) วิภันชัยพิทาโกเรียน ตัวกรองยูพี (ปีซีซี) เกี่ยวพันวิภันชัยพิทาโกเรียน ตัวกรองยูพี (ปีซีซี) เปรียบเทียบวิภันชัยพิทาโกเรียน ตัวกรองยูพี (ปีซีซี) เลื่อนวิภันชัยพิทาโกเรียน ไอดีลยูพี (ปีซีซี) วิภันชัยพิทาโกเรียน และไอดีลยูพี (ปีซีซี) เข้มวิภันชัยพิทาโกเรียน แล้วพิจารณาความสัมพันธ์ระหว่างบางประพจน์ของเขตวิภันชัยพิทาโกเรียน กับเขตวิภันชัยพิทาโกเรียนทั้ง 8 ชนิดในพิชคณิตยูพี (ปีซีซี) เพื่อศึกษาการวางนัยทั่วไปของเขตวิภันชัยพิทาโกเรียนทั้ง 8 ชนิดนี้ด้วยเงื่อนไขที่เพียงพอและศึกษาค่าใกล้เคียงบน ค่าใกล้เคียงล่าง หลังจากนั้นเราจะเราประยุกต์แนวคิดของเขตหยาบไปยังเขตวิภันชัยพิทาโกเรียนในพิชคณิตยูพี (ปีซีซี) และแนะนำเขตหยาบวิภันชัยพิทาโกเรียนในพิชคณิตยูพี (ปีซีซี) 24 ชนิด โดยให้ชื่อว่า พิชคณิตย่อยยูพี (ปีซีซี) วิภันชัยพิทาโกเรียนหยาบ(บน ล่าง) ตัวกรองยูพี (ปีซีซี) ไกลวิภันชัยพิทาโกเรียนหยาบ(บน ล่าง) ตัวกรองยูพี (ปีซีซี) วิภันชัยพิทาโกเรียนหยาบ(บน ล่าง) ตัวกรองยูพี (ปีซีซี) เกี่ยวพันวิภันชัยพิทาโกเรียนหยาบ(บน ล่าง) ตัวกรองยูพี (ปีซีซี) เปรียบเทียบวิภันชัยพิทาโกเรียนหยาบ(บน ล่าง) ตัวกรองยูพี (ปีซีซี) เลื่อนวิภันชัยพิทาโกเรียนหยาบ(บน ล่าง) ไอดีลยูพี (ปีซีซี) วิภันชัยพิทาโกเรียนหยาบ(บน ล่าง) และไอดีลยูพี (ปีซีซี) เข้มวิภันชัยพิทาโกเรียนหยาบ(บน ล่าง) แล้วศึกษาเขตย่อยระดับที่ของเขตวิภันชัยพิทาโกเรียนหยาบในพิชคณิตยูพี (ปีซีซี) ในท้ายที่สุดเราจะประยุกต์แนวคิดของเขตอ่อนวิภันชัยพิทาโกเรียนไปยังพิชคณิตยูพี (ปีซีซี) และแนะนำเขตอ่อนวิภันชัยพิทาโกเรียนเหนือพิชคณิตยูพี (ปีซีซี) 8 ชนิด โดยให้ชื่อว่า พิชคณิตย่อยยูพี (ปีซีซี) อ่อนวิภันชัยพิทาโกเรียน ตัวกรองยูพี (ปีซีซี) ไกลอ่อนวิภันชัยพิทาโกเรียน ตัวกรองยูพี (ปีซีซี) อ่อนวิภันชัยพิทาโกเรียน ตัวกรองยูพี (ปีซีซี) เกี่ยวพันอ่อนวิภันชัยพิทาโกเรียน ตัวกรองยูพี (ปีซีซี) เปรียบเทียบอ่อนวิภันชัยพิทาโกเรียน ตัวกรองยูพี (ปีซีซี) เลื่อนอ่อนวิภันชัยพิทาโกเรียน ไอดีลยูพี (ปีซีซี) อ่อนวิภันชัยพิทาโกเรียน และไอดีลยูพี (ปีซีซี) เข้มอ่อนวิภันชัยพิทาโกเรียน นอกจากนี้จะศึกษาผลลัพธ์ของการดำเนินการต่าง ๆ ในเขตอ่อนวิภันชัยพิทาโกเรียน 2 เขตในพิชคณิตยูพี (ปีซีซี) ได้แก่ ส่วนรวม(จำกัด) และส่วนรวม(ขยาย) แล้วยังศึกษาเขตย่อยระดับที่ของเขตอ่อนวิภันชัยพิทาโกเรียนในพิชคณิตยูพี (ปีซีซี)

Title: PYTHAGOREAN FUZZY SETS, ROUGH PYTHAGOREAN FUZZY SETS, AND PYTHAGOREAN FUZZY SOFT SETS IN UP (BCC)–ALGEBRAS

Author: Akarachai Satirad, Dissertation: Ph.D. (Mathematics), University of Phayao, 2023

Supervisor: Associate Professor Dr. Aiyared lampan

Co–Advisor: Associate Professor Dr. Tanakit Thianwan, Associate Professor Dr. Watcharaporn Cholanjiak

Keywords: UP–algebra, BCC–algebra, Pythagorean fuzzy set, rough Pythagorean fuzzy set, Pythagorean fuzzy soft set

ABSTRACT

Initially, we apply the concept of Pythagorean fuzzy sets to UP (BCC)–algebras, and introduce eight types of Pythagorean fuzzy sets in UP (BCC)–algebras, namely, Pythagorean fuzzy UP (BCC)–subalgebras, Pythagorean fuzzy near UP (BCC)–filters, Pythagorean fuzzy UP (BCC)–filters, Pythagorean fuzzy implicative UP (BCC)–filters, Pythagorean fuzzy comparative UP (BCC)–filters, Pythagorean fuzzy shift UP (BCC)–filters, Pythagorean fuzzy UP (BCC)–ideals, and Pythagorean fuzzy strong UP (BCC)–ideals. We discuss the relationship between some assertions of Pythagorean fuzzy sets and eight types of Pythagorean fuzzy sets in UP (BCC)–algebras for study the generalizations of eight Pythagorean fuzzy sets in UP (BCC)–algebras by finding sufficient conditions and study upper and lower approximations of Pythagorean fuzzy sets. Next, we apply the concept of rough sets to Pythagorean fuzzy sets in UP (BCC)–algebras, and introduce twenty–four types of rough Pythagorean fuzzy sets in UP (BCC)–algebras, namely, (upper, lower) rough Pythagorean fuzzy UP (BCC)–subalgebras, (upper, lower) rough Pythagorean fuzzy near UP (BCC)–filters, (upper, lower) rough Pythagorean fuzzy UP (BCC)–filters, (upper, lower) rough Pythagorean fuzzy implicative UP (BCC)–filters, (upper, lower) rough Pythagorean fuzzy comparative UP (BCC)–filters, (upper, lower) rough Pythagorean fuzzy shift UP (BCC)–filters, (upper, lower) rough Pythagorean fuzzy UP (BCC)–ideals, and (upper, lower) rough Pythagorean fuzzy strong UP (BCC)–ideals. We discuss t –level subsets of rough Pythagorean fuzzy sets in UP (BCC)–algebras. Finally, we apply the concept of Pythagorean fuzzy soft sets to UP (BCC)–algebras, and introduce eight types of Pythagorean fuzzy soft sets in UP (BCC)–algebras, namely, Pythagorean fuzzy soft UP (BCC)–subalgebras, Pythagorean fuzzy soft near UP (BCC)–filters, Pythagorean fuzzy soft UP (BCC)–filters, Pythagorean fuzzy soft implicative UP (BCC)–filters, Pythagorean fuzzy soft comparative UP (BCC)–filters, Pythagorean fuzzy soft shift UP (BCC)–filters, Pythagorean fuzzy soft UP (BCC)–ideals, and Pythagorean fuzzy soft strong UP (BCC)–ideals. In addition, we study the results of four operations of two Pythagorean fuzzy soft sets over UP (BCC)–algebras, namely, the union, the restricted union, the intersection, and the extended intersection and discuss t –level subsets of Pythagorean fuzzy soft sets over UP (BCC)–algebras.

LIST OF CONTENTS

Chapter	Page
I INTRODUCTION	1
II PRELIMINARIES	4
III PYTHAGOREAN FUZZY SETS	22
Pythagorean fuzzy sets in BCC-algebras	22
Properties of Pythagorean fuzzy sets	47
Upper and lower approximations of Pythagorean fuzzy sets	70
t -Level subsets of Pythagorean fuzzy sets	100
The operations on Pythagorean fuzzy sets	129
IV ROUGH PYTHAGOREAN FUZZY SETS	140
Rough Pythagorean fuzzy sets in BCC-algebras	140
t -Level subsets of rough Pythagorean fuzzy sets	162
V PYTHAGOREAN FUZZY SOFT SETS	175
Pythagorean fuzzy soft sets over BCC-algebras	175
The operations on Pythagorean fuzzy soft sets	197
t -Level subsets of Pythagorean fuzzy soft sets	215
VI CONCLUSIONS	223
BIBLIOGRAPHY	229
BIOGRAPHY	235

LIST OF FIGURES

Figures	Page
1	Pythagorean fuzzy sets in BCC-algebras 41
2	Properties of Pythagorean fuzzy sets in BCC-algebras 70
3	Rough Pythagorean fuzzy sets in BCC-algebras 144
4	Upper rough Pythagorean fuzzy sets in BCC-algebras 144
5	Lower rough Pythagorean fuzzy sets in BCC-algebras 145
6	Pythagorean fuzzy soft sets over BCC-algebras 197

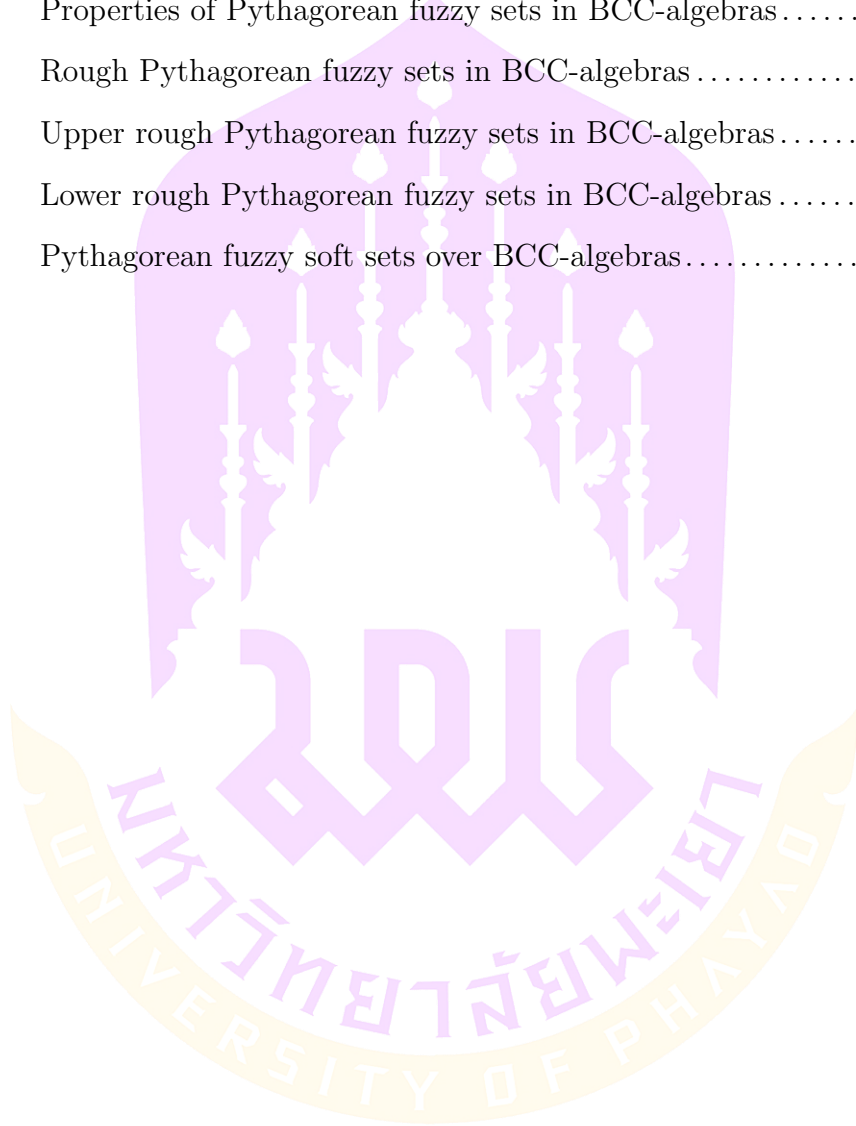

CHAPTER I

INTRODUCTION

Among many algebraic structures, algebras of logic form an important class of algebras. Examples of these are BCK-algebras [17], BCI-algebras [18], B-algebras [32], BE-algebras [25], UP-algebras [12], fully UP-semigroups [13], topological UP-algebras [41], UP-hyperalgebras [15], extension of KU/UP-algebras [37] and others. They are strongly connected with logic. For example, BCI-algebras introduced by Iséki [18] in 1966 have connections with BCI-logic being the BCI-system in combinatory logic which has application in the language of functional programming. BCK and BCI-algebras are two classes of logical algebras. They were introduced by Imai and Iséki [17, 18] in 1966 and have been extensively investigated by many researchers. In 2022, Jun et al. [21] have shown that the concept of UP-algebras (see [12]) and the concept of BCC-algebras (see [27]) are the same concept. Therefore, in this dissertation and future research, our research team will use the name BCC instead of UP in honour of Komori, who first defined it in 1984.

The concept of fuzzy sets was first considered by Zadeh [53] in 1965. Zadeh's and others' fuzzy set concepts have found numerous applications in mathematics and other fields. Following the introduction of the concept of fuzzy sets, various researchers were interviewed about generalizations of the concept of fuzzy sets, including: Atanassov [5] defined a new concept called an intuitionistic fuzzy set which is a generalization of a fuzzy set, Torra and Narukawa [49, 48] introduced the notion of hesitant fuzzy sets. Yager [51] introduced a new class of non-standard fuzzy subsets called a Pythagorean fuzzy set and the related idea of Pythagorean membership grades, and Satirad and Iampan [38] introduced several types of subsets and of fuzzy sets of fully BCC-semigroups, and investigated

the algebraic properties of fuzzy sets under the operations of intersection and union.

The concept of rough sets was first considered by Pawlak [33] in 1982. After the introduction of the concept of rough sets, several authors have applied the concept of rough sets to the generalizations of the concept of fuzzy sets in many algebraic structures such as: in 2002, Jun [20] and Dudek et al. [9] applied rough set theory to BCK-algebras and BCI-algebras. In 2008, Chen and Wang [6] combined rough sets and fuzzy subalgebras (fuzzy ideals) fruitfully by defining rough fuzzy subalgebras (rough fuzzy ideals) of BCI-algebras. In 2016, Moradiana et al. [30] presented a definition of the lower and upper approximation of subsets of BCK-algebras concerning a fuzzy ideal. In the same year, Ahn and Kim [1] introduced the concept of rough fuzzy filters in BE-algebras. In 2018, Ahn and Ko [2] introduced the concept of rough ideals and rough fuzzy ideals in BCK/BCI-algebras, In 2019-2020, Ansari et al. [4] and Klinseesook et al. [26] applied rough set theory to BCC-algebras. In 2019, Hussain et al. [11] introduced the concept of rough Pythagorean fuzzy ideals in semigroups.

The concept of Pythagorean fuzzy sets was applied to semigroups, ternary semigroups, and many logical algebras. Then, this idea is extended to the lower and upper approximations of Pythagorean fuzzy left (resp., right) ideals, bi-ideals, interior ideals, $(1, 2)$ -ideals in semigroups and some important properties related to these concepts are given. Jansi and Mohana [19] introduced the concepts of bipolar Pythagorean fuzzy A -ideals of BCI-algebras and investigated their properties. Also, relationships between bipolar Pythagorean fuzzy subalgebras, bipolar Pythagorean fuzzy ideals, and bipolar Pythagorean fuzzy A -ideals are analyzed. In 2020, Chinram and Panityakul [7] introduced rough Pythagorean fuzzy ideals in ternary semigroups and gave some remarkable properties. This idea is extended to the lower and upper approximations of Pythagorean fuzzy ideals.

In 1999, to solve complicated problems in economics, engineering, and the environment, we cannot successfully use classical methods because of various uncertainties typical for those problems. Uncertainties cannot be handled using traditional mathematical tools but may be dealt with using a wide range of existing theories such as the probability theory, the theory of (intuitionistic) fuzzy sets, the theory of vague sets, the theory of interval mathematics, and the theory of rough sets. However, all of these theories have their own difficulties which are pointed out in [29]. In 2001, Maji et al. [28] introduced the concept of fuzzy soft sets as a generalization of the standard soft sets, and presented an application of fuzzy soft sets in a decision-making problem. In 2013, Rehman et al. [36] studied properties of fuzzy soft sets and their interrelation with respect to different operations such as union, intersection, restricted union and extended intersection. Then, they illustrate properties of AND and OR operations by giving counterexamples. In 2015, Peng et al. [34] introduced the concept of Pythagorean fuzzy soft sets and defined the operations such as complement, union, intersection, and, or, addition, multiplication, necessity, and possibility. In 2017, Satirad et al. [44] discussed the relationships among (prime, weakly prime) hesitant fuzzy BCC-subalgebras (resp., hesitant fuzzy BCC-filters, hesitant fuzzy BCC-ideals and hesitant fuzzy strong BCC-ideals) and some level subsets of a hesitant fuzzy set on BCC-algebras. In 2018, Satirad et al. [38] introduced eight types of subsets and fuzzy sets of fully BCC-semigroups, and investigated the algebraic properties of fuzzy sets under the operations of intersection and union. In 2019, Satirad and Iampan [39, 40] introduced ten types of fuzzy soft sets over fully BCC-semigroups, and investigated the algebraic properties of fuzzy soft sets under the operations of (extended) intersection and (restricted) union. In 2020, Touqeer [50] introduced the notion of intuitionistic fuzzy soft α -ideals in BCI-algebras, described connections between various types of intuitionistic fuzzy soft α -ideals and intuitionistic fuzzy soft ideals and characterised using the idea of soft (δ, η) -level set.

CHAPTER II

PRELIMINARIES

Before we begin our study, let's review the definition of BCC-algebras.

Definition 2.0.1 [12] An algebra $X = (X, \cdot, 0)$ of type $(2, 0)$ is called a *BCC-algebra*, where X is a nonempty set, \cdot is a binary operation on X , and 0 is a fixed element of X (i.e., a nullary operation) if it satisfies the following axioms:

$$\text{(BCC-1)} \quad (\forall x, y, z \in X)((y \cdot z) \cdot ((x \cdot y) \cdot (x \cdot z)) = 0),$$

$$\text{(BCC-2)} \quad (\forall x \in X)(0 \cdot x = x),$$

$$\text{(BCC-3)} \quad (\forall x \in X)(x \cdot 0 = 0), \text{ and}$$

$$\text{(BCC-4)} \quad (\forall x, y \in X)(x \cdot y = 0, y \cdot x = 0 \Rightarrow x = y),$$

and is called a *KU-algebra* if it satisfies the following axioms: (BCC-2), (BCC-3), (BCC-4), and

$$\text{(KU)} \quad (\forall x, y, z \in X)((x \cdot y) \cdot ((y \cdot z) \cdot (x \cdot z)) = 0).$$

From [12], we know that the concept of BCC-algebras is a generalization of KU-algebras (see [35]).

Example 2.0.2 [43] Let X be a universal set and let $\Omega \in \mathcal{P}(X)$ where $\mathcal{P}(X)$ means the power set of X . Let $\mathcal{P}_\Omega(X) = \{A \in \mathcal{P}(X) \mid \Omega \subseteq A\}$. Define a binary operation \cdot on $\mathcal{P}_\Omega(X)$ by putting $A \cdot B = B \cap (A^C \cup \Omega)$ for all $A, B \in \mathcal{P}_\Omega(X)$ where A^C means the complement of a subset A . Then $(\mathcal{P}_\Omega(X), \cdot, \Omega)$ is a BCC-algebra and we shall call it the *generalized power BCC-algebra of type 1 with respect to Ω* . Let $\mathcal{P}^\Omega(X) = \{A \in \mathcal{P}(X) \mid A \subseteq \Omega\}$. Define a binary operation $*$ on $\mathcal{P}^\Omega(X)$ by putting $A * B = B \cup (A^C \cap \Omega)$ for all $A, B \in \mathcal{P}^\Omega(X)$. Then $(\mathcal{P}^\Omega(X), *, \Omega)$ is

a BCC-algebra and we shall call it the *generalized power BCC-algebra of type 2 with respect to Ω* . In particular, $(\mathcal{P}(X), \cdot, \emptyset)$ is a BCC-algebra and we shall call it the *power BCC-algebra of type 1*, and $(\mathcal{P}(X), *, X)$ is a BCC-algebra and we shall call it the *power BCC-algebra of type 2*.

Example 2.0.3 [8] Let \mathbb{N}_0 be the set of all natural numbers with zero. Define two binary operations $*$ and \bullet on \mathbb{N}_0 by

$$(\forall x, y \in \mathbb{N}_0) \left(x * y = \begin{cases} y & \text{if } x < y, \\ 0 & \text{otherwise} \end{cases} \right)$$

and

$$(\forall x, y \in \mathbb{N}_0) \left(x \bullet y = \begin{cases} y & \text{if } x > y \text{ or } x = 0, \\ 0 & \text{otherwise} \end{cases} \right).$$

Then $(\mathbb{N}_0, *, 0)$ and $(\mathbb{N}_0, \bullet, 0)$ are BCC-algebras.

For more examples of BCC-algebras, see [3, 4, 13, 16, 42, 43, 45, 46].

In a BCC-algebra $X = (X, \cdot, 0)$, the following assertions are valid (see [12, 13]).

$$(\forall x \in X)(x \cdot x = 0), \tag{2.0.1}$$

$$(\forall x, y, z \in X)(x \cdot y = 0, y \cdot z = 0 \Rightarrow x \cdot z = 0), \tag{2.0.2}$$

$$(\forall x, y, z \in X)(x \cdot y = 0 \Rightarrow (z \cdot x) \cdot (z \cdot y) = 0), \tag{2.0.3}$$

$$(\forall x, y, z \in X)(x \cdot y = 0 \Rightarrow (y \cdot z) \cdot (x \cdot z) = 0), \tag{2.0.4}$$

$$(\forall x, y \in X)(x \cdot (y \cdot x) = 0), \tag{2.0.5}$$

$$(\forall x, y \in X)((y \cdot x) \cdot x = 0 \Leftrightarrow x = y \cdot x), \tag{2.0.6}$$

$$(\forall x, y \in X)(x \cdot (y \cdot y) = 0), \tag{2.0.7}$$

$$(\forall a, x, y, z \in X)((x \cdot (y \cdot z)) \cdot (x \cdot ((a \cdot y) \cdot (a \cdot z))) = 0), \quad (2.0.8)$$

$$(\forall a, x, y, z \in X)((((a \cdot x) \cdot (a \cdot y)) \cdot z) \cdot ((x \cdot y) \cdot z) = 0), \quad (2.0.9)$$

$$(\forall x, y, z \in X)((x \cdot y) \cdot z \cdot (y \cdot z) = 0), \quad (2.0.10)$$

$$(\forall x, y, z \in X)(x \cdot y = 0 \Rightarrow x \cdot (z \cdot y) = 0), \quad (2.0.11)$$

$$(\forall x, y, z \in X)((x \cdot y) \cdot z \cdot (x \cdot (y \cdot z)) = 0), \text{ and} \quad (2.0.12)$$

$$(\forall a, x, y, z \in X)((x \cdot y) \cdot z \cdot (y \cdot (a \cdot z)) = 0). \quad (2.0.13)$$

From [12], the binary relation \leq on a BCC-algebra $X = (X, \cdot, 0)$ defined as follows:

$$(\forall x, y \in X)(x \leq y \Leftrightarrow x \cdot y = 0).$$

In a KU-algebra $X = (X, \cdot, 0)$, the following assertions are valid (see [31]).

$$(\forall x, y, z \in X)(x \cdot (y \cdot z) = y \cdot (x \cdot z)), \text{ and} \quad (2.0.14)$$

$$(\forall x, y \in X)(y \cdot ((y \cdot x) \cdot x) = 0). \quad (2.0.15)$$

Theorem 2.0.4 [12] *In a BCC-algebra $X = (X, \cdot, 0)$, the following statements are equivalent:*

- (1) X is a KU-algebra,
- (2) $(\forall x, y, z \in X)(x \cdot (y \cdot z) = y \cdot (x \cdot z))$, and
- (3) $(\forall x, y, z \in X)(x \cdot (y \cdot z) = 0 \Rightarrow y \cdot (x \cdot z) = 0)$.

For a nonempty subset S of a BCC-algebra $X = (X, \cdot, 0)$ which satisfies the following condition:

$$(\forall x, y \in X)(y \in S \Rightarrow x \cdot y \in S). \quad (2.0.16)$$

Then the constant 0 of X is in S . Indeed, let $x \in S$. By (2.0.1) and (2.0.16), we have $0 = x \cdot x \in S$.

Definition 2.0.5 A nonempty subset S of a BCC-algebra $X = (X, \cdot, 0)$ is called

- (1) a *BCC-subalgebra* [12] of X if it satisfies the following condition:

$$(\forall x, y \in S)(x \cdot y \in S), \quad (2.0.17)$$

- (2) a *near BCC-filter* [14] of X if it satisfies the condition (2.0.16),

- (3) a *BCC-filter* [47] of X if it satisfies the following conditions:

$$\text{the constant } 0 \text{ of } X \text{ is in } S, \quad (2.0.18)$$

$$(\forall x, y \in X)(x \cdot y \in S, x \in S \Rightarrow y \in S), \quad (2.0.19)$$

- (4) an *implicative BCC-filter* [23] of X if it satisfies the condition (2.0.18) and the following condition:

$$(\forall x, y, z \in X)(x \cdot (y \cdot z) \in S, x \cdot y \in S \Rightarrow x \cdot z \in S), \quad (2.0.20)$$

- (5) a *comparative BCC-filter* [22] of X if it satisfies the condition (2.0.18) and the following condition:

$$(\forall x, y, z \in X)(x \cdot ((y \cdot z) \cdot y) \in S, x \in S \Rightarrow y \in S), \quad (2.0.21)$$

- (6) a *shift BCC-filter* [24] of X if it satisfies the condition (2.0.18) and the following condition:

$$(\forall x, y, z \in X)(x \cdot (y \cdot z) \in S, x \in S \Rightarrow ((z \cdot y) \cdot y) \cdot z \in S), \quad (2.0.22)$$

(7) a *BCC-ideal* [12] of X if it satisfies the condition (2.0.18) and the following condition:

$$(\forall x, y, z \in X)(x \cdot (y \cdot z) \in S, y \in S \Rightarrow x \cdot z \in S), \quad (2.0.23)$$

(8) a *strong BCC-ideal* [10] of X if it satisfies the condition (2.0.18) and the following condition:

$$(\forall x, y, z \in X)((z \cdot y) \cdot (z \cdot x) \in S, y \in S \Rightarrow x \in S). \quad (2.0.24)$$

We have that the concept of BCC-subalgebras is a generalization of near BCC-filters, near BCC-filters is a generalization of BCC-filters, BCC-filters is a generalization of BCC-ideals, BCC-filters is a generalization of comparative BCC-filters, BCC-filters is a generalization of shift BCC-filters, BCC-ideals is a generalization of implicative BCC-filters, implicative BCC-filters is a generalization of strong BCC-ideals, comparative BCC-filters is a generalization of strong BCC-ideals, and shift BCC-filters is a generalization of strong BCC-ideals. Furthermore, they proved that the only strong BCC-ideal of a BCC-algebra X is X .

Definition 2.0.6 [53] A *fuzzy set* F in a nonempty set X (or a *fuzzy subset* of X) is described by its membership function f_F . To every point $x \in X$, this function associates a real number $f_F(x)$ in the closed interval $[0, 1]$. The real number $f_F(x)$ is interpreted for the point as a degree of membership of an object $x \in X$ to the fuzzy set F , that is, $F := \{(x, f_F(x)) \mid x \in X\}$. We say that a fuzzy set F in X is *constant* if its membership function f_F is constant.

Definition 2.0.7 [53] Let F be a fuzzy set in a nonempty set X . The *complement* of F , denoted by \tilde{F} , is described by its membership function $f_{\tilde{F}}$ which defined as

follows:

$$(\forall x \in X)(f_{\tilde{F}}(x) = 1 - f_F(x)). \quad (2.0.25)$$

Definition 2.0.8 [53] Let F_1 and F_2 be fuzzy sets in a nonempty set X . The relations \subseteq and $=$, and the operations \cup and \cap are defined as follows:

- (1) $F_1 \subseteq F_2 \Leftrightarrow (\forall x \in X)(f_{F_1}(x) \leq f_{F_2}(x))$,
- (2) $F_1 = F_2 \Leftrightarrow F_1 \subseteq F_2, F_1 \supseteq F_2$,
- (3) $(\forall x \in X)((f_{F_1} \cup f_{F_2})(x) = \max\{f_{F_1}(x), f_{F_2}(x)\})$, and
- (4) $(\forall x \in X)((f_{F_1} \cap f_{F_2})(x) = \min\{f_{F_1}(x), f_{F_2}(x)\})$.

The following two propositions are easy to verify.

Proposition 2.0.9 *Let F be a fuzzy set in a nonempty set X . Then following assertions are valid:*

- (1) $(\forall x, y \in X)(f_F(x) \leq f_F(y) \Leftrightarrow f_{\tilde{F}}(x) \geq f_{\tilde{F}}(y))$,
- (2) $(\forall x, y \in X)(f_F(x) = f_F(y) \Leftrightarrow f_{\tilde{F}}(x) = f_{\tilde{F}}(y))$,
- (3) $\tilde{\tilde{F}} = F$, and
- (4) $(\forall x, y \in X)(1 - \min\{f_F(x), f_F(y)\} = \max\{f_{\tilde{F}}(x), f_{\tilde{F}}(y)\} = \max\{1 - f_F(x), 1 - f_F(y)\})$.

Proposition 2.0.10 *Let $\{F_i\}_{i \in I}$ be a nonempty family of fuzzy sets in a nonempty set X where I is an arbitrary index set. Then following assertions are valid:*

- (1) $(\forall x, y \in X)(\inf_{i \in I}\{\min\{f_{F_i}(x), f_{F_i}(y)\}\} = \min\{\inf_{i \in I}\{f_{F_i}(x)\}, \inf_{i \in I}\{f_{F_i}(y)\}\})$,
- (2) $(\forall x, y \in X)(\sup_{i \in I}\{\max\{f_{F_i}(x), f_{F_i}(y)\}\} = \max\{\sup_{i \in I}\{f_{F_i}(x)\}, \sup_{i \in I}\{f_{F_i}(y)\}\})$,

$$(3) (\forall x, y \in X)(\inf_{i \in I}\{\max\{f_{F_i}(x), f_{F_i}(y)\}\} \geq \max\{\inf_{i \in I}\{f_{F_i}(x)\}, \inf_{i \in I}\{f_{F_i}(y)\}\}),$$

$$(4) (\forall x, y \in X)(\sup_{i \in I}\{\min\{f_{F_i}(x), f_{F_i}(y)\}\} \leq \min\{\sup_{i \in I}\{f_{F_i}(x)\}, \sup_{i \in I}\{f_{F_i}(y)\}\}),$$

$$(5) (\forall x \in X)(\sup_{i \in I}\{f_{F_i}(x)\}^2 = \sup_{i \in I}\{f_{F_i}(x^2)\}),$$

$$(6) (\forall x \in X)(\inf_{i \in I}\{f_{F_i}(x)\}^2 = \inf_{i \in I}\{f_{F_i}(x^2)\}),$$

$$(7) (\forall x \in X)(1 - \sup_{i \in I}\{f_{F_i}(x)\} = \inf_{i \in I}\{1 - f_{F_i}(x)\}), \text{ and}$$

$$(8) (\forall x \in X)(1 - \inf_{i \in I}\{f_{F_i}(x)\} = \sup_{i \in I}\{1 - f_{F_i}(x)\}).$$

For a fuzzy set F in a BCC-algebra $X = (X, \cdot, 0)$ which satisfies the following condition:

$$(\forall x, y \in X)(f_F(x \cdot y) \geq f_F(y)). \quad (2.0.26)$$

Then

$$(\forall x \in X)(f_F(0) \geq f_F(x)).$$

Indeed, let $x \in X$. By (2.0.1) and (2.0.26), we have $f_F(0) = f_F(x \cdot x) \geq f_F(x)$.

Definition 2.0.11 A fuzzy set F in a BCC-algebra $X = (X, \cdot, 0)$ is called

(1) a *fuzzy BCC-subalgebra* [47] of X if it satisfies the following condition:

$$(\forall x, y \in X)(f_F(x \cdot y) \geq \min\{f_F(x), f_F(y)\}), \quad (2.0.27)$$

(2) a *fuzzy near BCC-filter* [39] of X if it satisfies the condition (2.0.26),

(3) a *fuzzy BCC-filter* [47] of X if it satisfies the following conditions:

$$(\forall x \in X)(f_F(0) \geq f_F(x)), \quad (2.0.28)$$

$$(\forall x, y \in X)(f_F(y) \geq \min\{f_F(x \cdot y), f_F(x)\}), \quad (2.0.29)$$

- (4) a *fuzzy implicative BCC-filter* of X if it satisfies the condition (2.0.28) and the following condition:

$$(\forall x, y, z \in X)(f_F(x \cdot z) \geq \min\{f_F(x \cdot (y \cdot z)), f_F(x \cdot y)\}), \quad (2.0.30)$$

- (5) a *fuzzy comparative BCC-filter* of X if it satisfies the condition (2.0.28) and the following condition:

$$(\forall x, y, z \in X)(f_F(y) \geq \min\{f_F(x \cdot ((y \cdot z) \cdot y)), f_F(x)\}), \quad (2.0.31)$$

- (6) a *fuzzy shift BCC-filter* of X if it satisfies the condition (2.0.28) and the following condition:

$$(\forall x, y, z \in X)(f_F(((z \cdot y) \cdot y) \cdot z) \geq \min\{f_F(x \cdot (y \cdot z)), f_F(x)\}), \quad (2.0.32)$$

- (7) a *fuzzy BCC-ideal* [47] of X if it satisfies the condition (2.0.28) and the following condition:

$$(\forall x, y, z \in X)(f_F(x \cdot z) \geq \min\{f_F(x \cdot (y \cdot z)), f_F(y)\}), \quad (2.0.33)$$

- (8) a *fuzzy strong BCC-ideal* [10] of X if it satisfies the condition (2.0.28) and the following condition:

$$(\forall x, y, z \in X)(f_F(x) \geq \min\{f_F((z \cdot y) \cdot (z \cdot x)), f_F(y)\}). \quad (2.0.34)$$

We have that the concept of fuzzy BCC-subalgebras is a generalization of fuzzy near BCC-filters, fuzzy near BCC-filters is a generalization of fuzzy BCC-filters, fuzzy BCC-filters is a generalization of fuzzy BCC-ideals, and fuzzy BCC-ideals is a generalization of fuzzy strong BCC-ideals. Furthermore, they proved

that fuzzy strong BCC-ideals and constant fuzzy sets coincide in a BCC-algebras X .

Let ρ be an equivalence relation on a BCC-algebra $X = (X, \cdot, 0)$. If $x \in X$, then the ρ -class of x is the set $(x)_\rho$ defined as follows:

$$(x)_\rho = \{y \in X \mid (x, y) \in \rho\}.$$

An equivalence relation ρ on a BCC-algebra $X = (X, \cdot, 0)$ is called a *congruence relation* if

$$(\forall x, y, z \in X)((x, y) \in \rho \Rightarrow (x \cdot z, y \cdot z) \in \rho \text{ and } (z \cdot x, z \cdot y) \in \rho).$$

Definition 2.0.12 For nonempty subsets A and B of a BCC-algebra $X = (X, \cdot, 0)$, we denote

$$AB = A \cdot B = \{a \cdot b \mid a \in A \text{ and } b \in B\}.$$

If ρ is a congruence on a BCC-algebra $X = (X, \cdot, 0)$, then

$$(\forall x, y \in X)((x)_\rho(y)_\rho \subseteq (x \cdot y)_\rho). \quad (\text{see [26]})$$

A congruence relation ρ on a BCC-algebra $X = (X, \cdot, 0)$ is said to be *complete* if

$$(\forall x, y \in X)((x)_\rho(y)_\rho = (x \cdot y)_\rho).$$

Example 2.0.13 Let $X = \{0, 1, 2, 3\}$ be a BCC-algebra with a fixed element 0

and a binary operation \cdot defined by the following Cayley table:

\cdot	0	1	2	3
0	0	1	2	3
1	0	0	2	3
2	0	0	0	1
3	0	0	0	0

Let

$$\rho = \{(0, 0), (1, 1), (2, 2), (3, 3), (0, 1), (1, 0), (2, 3), (3, 2)\}.$$

Then ρ is a congruence relation on X . Thus

$$(0)_\rho = (1)_\rho = \{0, 1\}, (2)_\rho = (3)_\rho = \{2, 3\}.$$

We consider

$$(0 \cdot 0)_\rho = (0)_\rho = \{0, 1\} = \{0, 1\} = \{0, 1\}\{0, 1\} = (0)_\rho(0)_\rho,$$

$$(0 \cdot 1)_\rho = (1)_\rho = \{0, 1\} = \{0, 1\} = \{0, 1\}\{0, 1\} = (0)_\rho(1)_\rho,$$

$$(0 \cdot 2)_\rho = (2)_\rho = \{2, 3\} = \{2, 3\} = \{0, 1\}\{2, 3\} = (0)_\rho(2)_\rho,$$

$$(0 \cdot 3)_\rho = (3)_\rho = \{2, 3\} = \{2, 3\} = \{0, 1\}\{2, 3\} = (0)_\rho(3)_\rho,$$

$$(1 \cdot 0)_\rho = (0)_\rho = \{0, 1\} = \{0, 1\} = \{0, 1\}\{0, 1\} = (1)_\rho(0)_\rho,$$

$$(1 \cdot 1)_\rho = (0)_\rho = \{0, 1\} = \{0, 1\} = \{0, 1\}\{0, 1\} = (1)_\rho(1)_\rho,$$

$$(1 \cdot 2)_\rho = (2)_\rho = \{2, 3\} = \{2, 3\} = \{0, 1\}\{2, 3\} = (1)_\rho(2)_\rho,$$

$$(1 \cdot 3)_\rho = (3)_\rho = \{2, 3\} = \{2, 3\} = \{0, 1\}\{2, 3\} = (1)_\rho(3)_\rho,$$

$$(2 \cdot 0)_\rho = (0)_\rho = \{0, 1\} = \{0, 1\} = \{2, 3\}\{0, 1\} = (2)_\rho(0)_\rho,$$

$$(2 \cdot 1)_\rho = (0)_\rho = \{0, 1\} = \{0, 1\} = \{2, 3\}\{0, 1\} = (2)_\rho(1)_\rho,$$

$$(2 \cdot 2)_\rho = (0)_\rho = \{0, 1\} = \{0, 1\} = \{2, 3\}\{2, 3\} = (2)_\rho(2)_\rho,$$

$$(2 \cdot 3)_\rho = (1)_\rho = \{0, 1\} = \{0, 1\} = \{2, 3\}\{2, 3\} = (2)_\rho(3)_\rho,$$

$$(3 \cdot 0)_\rho = (0)_\rho = \{0, 1\} = \{0, 1\} = \{2, 3\}\{0, 1\} = (3)_\rho(0)_\rho,$$

$$(3 \cdot 1)_\rho = (0)_\rho = \{0, 1\} = \{0, 1\} = \{2, 3\}\{0, 1\} = (3)_\rho(1)_\rho,$$

$$(3 \cdot 2)_\rho = (0)_\rho = \{0, 1\} = \{0, 1\} = \{2, 3\}\{2, 3\} = (3)_\rho(2)_\rho,$$

$$(3 \cdot 3)_\rho = (0)_\rho = \{0, 1\} = \{0, 1\} = \{2, 3\}\{2, 3\} = (3)_\rho(3)_\rho.$$

Hence, ρ is a complete congruence relation on X .

Definition 2.0.14 Let ρ be an equivalence relation on a nonempty set X and $S \in \mathcal{P}(X)$. The *upper approximation* of S is defined by

$$\rho^+(S) = \{x \in X \mid (x)_\rho \subseteq S\},$$

the *lower approximation* of S is defined by

$$\rho^-(S) = \{x \in X \mid (x)_\rho \cap S \neq \emptyset\}.$$

We know that $\rho^+(S)$ and $\rho^-(S)$ are subset of X . Then we call S that a *rough set* of X .

Definition 2.0.15 [26] Let ρ be an equivalence relation on a BCC-algebra $X = (X, \cdot, 0)$. Then a nonempty subset S of X is called

- (1) an *upper rough BCC-subalgebra* of X if $\rho^+(S)$ is a BCC-subalgebra of X ,
- (2) an *upper rough near BCC-filter* of X if $\rho^+(S)$ is a near BCC-filter of X ,

- (3) an *upper rough BCC-filter* of X if $\rho^+(P)$ is a BCC-filter of X ,
- (4) an *upper rough BCC-ideal* of X if $\rho^+(S)$ is a BCC-ideal of X ,
- (5) an *upper rough strong BCC-ideal* of X if $\rho^+(S)$ is a strong BCC-ideal of X ,
- (6) a *lower rough BCC-subalgebra* of X if $\emptyset \neq \rho^-(S)$ is a BCC-subalgebra of X ,
- (7) a *lower rough near BCC-filter* of X if $\emptyset \neq \rho^-(S)$ is a near BCC-filter of X ,
- (8) a *lower rough BCC-filter* of X if $\emptyset \neq \rho^-(S)$ is a BCC-filter of X ,
- (9) a *lower rough BCC-ideal* of X if $\emptyset \neq \rho^-(S)$ is a BCC-ideal of X ,
- (10) a *lower rough strong BCC-ideal* of X if $\emptyset \neq \rho^-(S)$ is a strong BCC-ideal of X ,
- (11) a *rough BCC-subalgebra* of X if it is both an upper rough BCC-subalgebra and a lower rough BCC-subalgebra of X ,
- (12) a *rough near BCC-filter* of X if it is both an upper rough near BCC-filter and a lower rough near BCC-filter of X ,
- (13) a *rough BCC-filter* of X if it is both an upper rough BCC-filter and a lower rough BCC-filter of X ,
- (14) a *rough BCC-ideal* of X if it is both an upper rough BCC-ideal and a lower rough BCC-ideal of X , and
- (15) a *rough strong BCC-ideal* of X if it is both an upper rough strong BCC-ideal and a lower rough strong BCC-ideal of X .

Definition 2.0.16 [51, 52] A *Pythagorean fuzzy set* P in a nonempty set X is described by their membership function μ_P and non-membership function ν_P . To

every point $x \in X$, these functions associate real numbers $\mu_P(x)$ and $\nu_P(x)$ in the closed interval $[0, 1]$, with the following condition:

$$(\forall x \in X)(0 \leq \mu_P(x)^2 + \nu_P(x)^2 \leq 1). \quad (2.0.35)$$

The real numbers $\mu_P(x)$ and $\nu_P(x)$ are interpreted for the point as a degree of membership and non-membership of an object $x \in X$, respectively, to the Pythagorean fuzzy set P , that is, $P := \{(x, \mu_P(x), \nu_P(x)) \mid x \in X\}$. For the sake of simplicity, a Pythagorean fuzzy set P is denoted by $P = (\mu_P, \nu_P)$. We say that a Pythagorean fuzzy set P in X is *constant* if their membership function μ_P and non-membership function ν_P are constant.

Definition 2.0.17 Let $P = (\mu_P, \nu_P)$ and $Q = (\mu_Q, \nu_Q)$ be Pythagorean fuzzy sets in X . The relations \subseteq and $=$, and the operations \cup and \cap are defined as follows:

- (1) $P \subseteq Q \Leftrightarrow (\forall x \in X)(\mu_P(x) \leq \mu_Q(x), \nu_P(x) \geq \nu_Q(x))$,
- (2) $P = Q \Leftrightarrow P \subseteq Q, P \supseteq Q$,
- (3) $P \cup Q = (\mu_P \cup \mu_Q, \nu_P \cap \nu_Q)$, and
- (4) $P \cap Q = (\mu_P \cap \mu_Q, \nu_P \cup \nu_Q)$.

Note that, $P \cup Q$ and $P \cap Q$ are Pythagorean fuzzy sets in X . Indeed, let $x \in X$. Then $(\mu_P \cup \mu_Q)(x) = \max\{\mu_P(x), \mu_Q(x)\}$ and $(\nu_P \cap \nu_Q)(x) = \min\{\nu_P(x), \nu_Q(x)\}$. Thus we consider

$$\begin{aligned} 0 &\leq ((\mu_P \cup \mu_Q)(x))^2 + ((\nu_P \cap \nu_Q)(x))^2 \\ &= \max\{\mu_P(x), \mu_Q(x)\}^2 + \min\{\nu_P(x), \nu_Q(x)\}^2 \\ &= (\mu_P(x))^2 + \min\{\nu_P(x), \nu_Q(x)\}^2 \end{aligned}$$

(WLOG, assume that $\max\{\mu_P(x), \mu_Q(x)\} = \mu_P(x)$)

$$\begin{aligned} &\leq (\mu_P(x))^2 + (\nu_P(x))^2 \\ &\leq 1. \end{aligned}$$

This implies that $P \cup Q$ is a Pythagorean fuzzy set in X . The proof of $P \cap Q$ is similar to the proof of $P \cup Q$. Hence, we can denote $P \cup Q = (\mu_P \cup \mu_Q, \nu_P \cap \nu_Q) = (\mu_{P \cup Q}, \nu_{P \cup Q})$ and $P \cap Q = (\mu_P \cap \mu_Q, \nu_P \cup \nu_Q) = (\mu_{P \cap Q}, \nu_{P \cap Q})$.

Definition 2.0.18 [51] Let $\{P_i = (\mu_{P_i}, \nu_{P_i})\}_{i \in I}$ be a nonempty family of Pythagorean fuzzy sets in a nonempty set X where I is an arbitrary index set. The *intersection* of P_i , denoted by $\bigwedge_{i \in I} P_i$, is described by their membership function $\mu_{\bigwedge_{i \in I} P_i}$ and non-membership function $\nu_{\bigwedge_{i \in I} P_i}$ which defined as follows:

$$\begin{aligned} (\forall x \in X) (\mu_{\bigwedge_{i \in I} P_i}(x) &= \inf\{\mu_{P_i}(x)\}_{i \in I}), \\ (\forall x \in X) (\nu_{\bigwedge_{i \in I} P_i}(x) &= \sup\{\nu_{P_i}(x)\}_{i \in I}). \end{aligned}$$

The *union* of P_i , denoted by $\bigvee_{i \in I} P_i$, is described by their membership function $\mu_{\bigvee_{i \in I} P_i}$ and non-membership function $\nu_{\bigvee_{i \in I} P_i}$ which defined as follows:

$$\begin{aligned} (\forall x \in X) (\mu_{\bigvee_{i \in I} P_i}(x) &= \sup\{\mu_{P_i}(x)\}_{i \in I}), \\ (\forall x \in X) (\nu_{\bigvee_{i \in I} P_i}(x) &= \inf\{\nu_{P_i}(x)\}_{i \in I}). \end{aligned}$$

In particular, if $I = \{1, 2, \dots, n\}$, the intersection of P_1, P_2, \dots, P_n , denoted by $P_1 \wedge P_2 \wedge \dots \wedge P_n$, is described by their membership function $\mu_{P_1 \wedge P_2 \wedge \dots \wedge P_n}$ and non-membership function $\nu_{P_1 \wedge P_2 \wedge \dots \wedge P_n}$ which defined as follows:

$$\begin{aligned} (\forall x \in X) (\mu_{P_1 \wedge P_2 \wedge \dots \wedge P_n}(x) &= \min\{\mu_{P_1}(x), \mu_{P_2}(x), \dots, \mu_{P_n}(x)\}), \\ (\forall x \in X) (\nu_{P_1 \wedge P_2 \wedge \dots \wedge P_n}(x) &= \max\{\nu_{P_1}(x), \nu_{P_2}(x), \dots, \nu_{P_n}(x)\}). \end{aligned}$$

The union of P_1, P_2, \dots, P_n , denoted by $P_1 \vee P_2 \vee \dots \vee P_n$, is described by their membership function $\mu_{P_1 \vee P_2 \vee \dots \vee P_n}$ and non-membership function $\nu_{P_1 \vee P_2 \vee \dots \vee P_n}$ which defined as follows:

$$(\forall x \in X)(\mu_{P_1 \vee P_2 \vee \dots \vee P_n}(x) = \max\{\mu_{P_1}(x), \mu_{P_2}(x), \dots, \mu_{P_n}(x)\}),$$

$$(\forall x \in X)(\nu_{P_1 \vee P_2 \vee \dots \vee P_n}(x) = \min\{\nu_{P_1}(x), \nu_{P_2}(x), \dots, \nu_{P_n}(x)\}).$$

From now on, we shall let E be a set of parameters. Let $\text{PF}(X)$ be the set of all Pythagorean fuzzy sets in a universal set X . A subset A of E is called a set of statistics.

Definition 2.0.19 [34] Let $A \subseteq E$. A pair (\tilde{P}, A) is called a *Pythagorean fuzzy soft set* over X if \tilde{P} is a mapping given by $\tilde{P}: A \rightarrow \text{PF}(X)$, that is, a Pythagorean fuzzy soft set is a statistic family of Pythagorean fuzzy sets in X . In general, for every $a \in A$, $\tilde{P}[a] := \{(x, \mu_{\tilde{P}[a]}(x), \nu_{\tilde{P}[a]}(x)) \mid x \in X\}$ is a Pythagorean fuzzy set in X and it is called a *Pythagorean fuzzy value set* of statistic a . We call a Pythagorean fuzzy soft set (\tilde{P}, A) over X that is a *constant Pythagorean fuzzy soft set* based on the element $a \in A$ (we shortly call an *a-constant Pythagorean fuzzy soft set*) of X if a Pythagorean fuzzy set $\tilde{P}[a]$ in X is a constant Pythagorean fuzzy set. If (\tilde{P}, A) is an *a-constant Pythagorean fuzzy soft set* of X for all $a \in A$, we say that (\tilde{P}, A) is a *constant Pythagorean fuzzy soft set* of X .

By Definition 2.0.19, we can find an example of Pythagorean fuzzy soft sets over BCC-algebras $X = (X, \cdot, 0)$ as follows:

Example 2.0.20 Let $X = \{0, 1, 2, 3\}$ be a set which represents a collection of 4

Thai paintings. Define binary operation \cdot on X as the following Cayley tables:

\cdot	0	1	2	3
0	0	1	2	3
1	0	0	0	3
2	0	1	0	3
3	0	1	2	0

Then $X = (X, \cdot, 0)$ is a BCC-algebra. Let

$$A = \{\text{identity, beauty, skill}\}$$

with $\tilde{P}[\text{identity}]$, $\tilde{P}[\text{beauty}]$, and $\tilde{P}[\text{skill}]$ are Pythagorean fuzzy sets in X defined as follows:

\tilde{P}	0	1	2	3
identity	(0.4, 0.5)	(0.3, 0.3)	(0.1, 0.6)	(0.8, 0.2)
beauty	(0.9, 0.3)	(0.2, 0.5)	(0.1, 0.2)	(0.8, 0.4)
skill	(0.3, 0.5)	(0.3, 0.7)	(0.5, 0.6)	(0.7, 0.7)

Hence, (\tilde{P}, A) is a Pythagorean fuzzy soft set over X .

Definition 2.0.21 [34] Let $A, B \subseteq E$ and $(\tilde{P}, A), (\tilde{Q}, B)$ be two Pythagorean fuzzy soft sets over X . If (\tilde{P}, A) and (\tilde{Q}, B) satisfy the following two conditions:

- (1) $B \subseteq A$ and
- (2) $(\forall b \in B, x \in X)(\mu_{\tilde{Q}[b]}(x) \leq \mu_{\tilde{P}[b]}(x), \nu_{\tilde{Q}[b]}(x) \geq \nu_{\tilde{P}[b]}(x))$,

then we call (\tilde{Q}, B) the Pythagorean fuzzy soft subset of (\tilde{P}, A) , denoted by $(\tilde{Q}, B) \tilde{\subseteq} (\tilde{P}, A)$.

Definition 2.0.22 [34] Let $A, B \subseteq E$ and $(\tilde{P}, A), (\tilde{Q}, B)$ be two Pythagorean fuzzy soft sets over X . If $(\tilde{Q}, B) \subseteq (\tilde{P}, A)$ and $(\tilde{P}, A) \subseteq (\tilde{Q}, B)$, then we call (\tilde{P}, A) equal (\tilde{Q}, B) , denoted by $(\tilde{Q}, B) \cong (\tilde{P}, A)$, meaning, $A = B$ and $\tilde{P}[a] = \tilde{Q}[a]$ for all $a \in A$.

Definition 2.0.23 [34] Let (\tilde{P}_1, A_1) and (\tilde{P}_2, A_2) be two Pythagorean fuzzy soft sets over X . The *union* of (\tilde{P}_1, A_1) and (\tilde{P}_2, A_2) is defined to be the Pythagorean fuzzy soft set $(\tilde{P}_1, A_1) \tilde{\cup} (\tilde{P}_2, A_2) = (\tilde{P}, A)$ satisfying the following conditions:

(i) $A = A_1 \cup A_2$ and

(ii) for all $a \in A$,

$$\tilde{P}[a] = \begin{cases} \tilde{P}_1[a] & \text{if } a \in A_1 \setminus A_2 \\ \tilde{P}_2[a] & \text{if } a \in A_2 \setminus A_1 \\ \tilde{P}_1[a] \vee \tilde{P}_2[a] & \text{if } a \in A_1 \cap A_2. \end{cases}$$

The *restricted union* of (\tilde{P}_1, A_1) and (\tilde{P}_2, A_2) is defined to be the Pythagorean fuzzy soft set $(\tilde{P}_1, A_1) \tilde{\cup} (\tilde{P}_2, A_2) = (\tilde{P}, A)$ satisfying the following conditions:

(i) $A = A_1 \cap A_2 \neq \emptyset$ and

(ii) $\tilde{P}[a] = \tilde{P}_1[a] \vee \tilde{P}_2[a]$ for all $a \in A$.

Definition 2.0.24 Let (\tilde{P}_1, A_1) and (\tilde{P}_2, A_2) be two Pythagorean fuzzy soft sets over X . The *extended intersection* of (\tilde{P}_1, A_1) and (\tilde{P}_2, A_2) is defined to be the Pythagorean fuzzy soft set $(\tilde{P}_1, A_1) \tilde{\cap} (\tilde{P}_2, A_2) = (\tilde{P}, A)$ satisfying the following conditions:

(i) $A = A_1 \cup A_2$ and

(ii) for all $a \in A$,

$$\tilde{P}[a] = \begin{cases} \tilde{P}_1[a] & \text{if } a \in A_1 \setminus A_2 \\ \tilde{P}_2[a] & \text{if } a \in A_2 \setminus A_1 \\ \tilde{P}_1[a] \wedge \tilde{P}_2[a] & \text{if } a \in A_1 \cap A_2. \end{cases}$$

The *intersection* [34] of (\tilde{P}_1, A_1) and (\tilde{P}_2, A_2) is defined to be the fuzzy soft set $(\tilde{P}_1, A_1) \tilde{\cap} (\tilde{P}_2, A_2) = (\tilde{P}, A)$ satisfying the following conditions:

- (i) $A = A_1 \cap A_2 \neq \emptyset$ and
- (ii) $\tilde{P}[a] = \tilde{P}_1[a] \wedge \tilde{P}_2[a]$ for all $a \in A$.

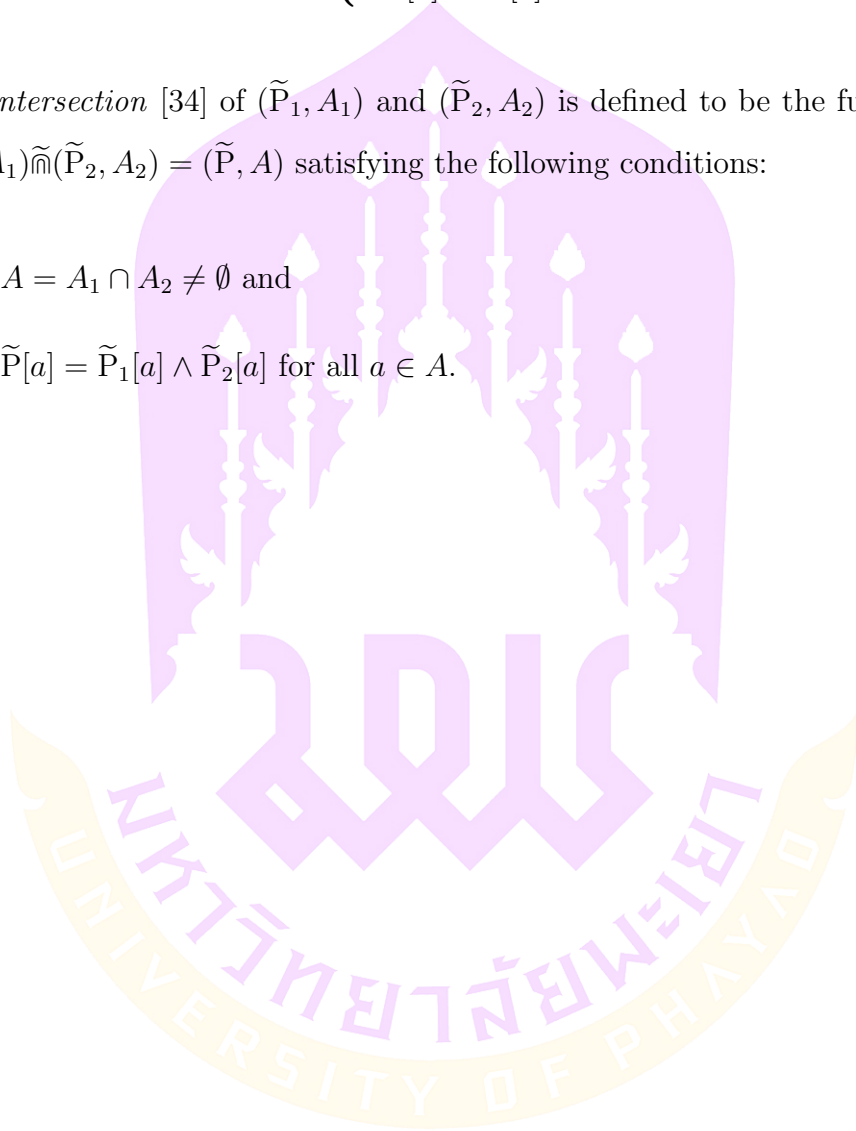

CHAPTER III

PYTHAGOREAN FUZZY SETS

Next, we shall let X be a BCC-algebra $X = (X, \cdot, 0)$.

3.1 Pythagorean fuzzy sets in BCC-algebras

We apply the concept of Pythagorean fuzzy sets to BCC-algebras and introduce the eight types of Pythagorean fuzzy sets in BCC-algebras.

Definition 3.1.1 A Pythagorean fuzzy set $P = (\mu_P, \nu_P)$ in X is called

- (1) a *Pythagorean fuzzy BCC-subalgebra* of X if it satisfies the following conditions:

$$(\forall x, y \in X)(\mu_P(x \cdot y) \geq \min\{\mu_P(x), \mu_P(y)\}), \quad (3.1.1)$$

$$(\forall x, y \in X)(\nu_P(x \cdot y) \leq \max\{\nu_P(x), \nu_P(y)\}), \quad (3.1.2)$$

- (2) a *Pythagorean fuzzy near BCC-filter* of X if it satisfies the following conditions:

$$(\forall x, y \in X)(\mu_P(x \cdot y) \geq \mu_P(y)), \quad (3.1.3)$$

$$(\forall x, y \in X)(\nu_P(x \cdot y) \leq \nu_P(y)), \quad (3.1.4)$$

- (3) a *Pythagorean fuzzy BCC-filter* of X if it satisfies the following conditions:

$$(\forall x \in X)(\mu_P(0) \geq \mu_P(x)), \quad (3.1.5)$$

$$(\forall x \in X)(\nu_P(0) \leq \nu_P(x)), \quad (3.1.6)$$

$$(\forall x, y \in X)(\mu_P(y) \geq \min\{\mu_P(x \cdot y), \mu_P(x)\}), \quad (3.1.7)$$

$$(\forall x, y \in X)(\nu_P(y) \leq \max\{\nu_P(x \cdot y), \nu_P(x)\}), \quad (3.1.8)$$

- (4) a *Pythagorean fuzzy implicative BCC-filter* of X if it satisfies the conditions (3.1.5) and (3.1.6) and the following conditions:

$$(\forall x, y, z \in X)(\mu_P(x \cdot z) \geq \min\{\mu_P(x \cdot (y \cdot z)), \mu_P(x \cdot y)\}), \quad (3.1.9)$$

$$(\forall x, y, z \in X)(\nu_P(x \cdot z) \leq \max\{\nu_P(x \cdot (y \cdot z)), \nu_P(x \cdot y)\}), \quad (3.1.10)$$

- (5) a *Pythagorean fuzzy comparative BCC-filter* of X if it satisfies the conditions (3.1.5) and (3.1.6) and the following conditions:

$$(\forall x, y, z \in X)(\mu_P(y) \geq \min\{\mu_P(x \cdot ((y \cdot z) \cdot y)), \mu_P(x)\}), \quad (3.1.11)$$

$$(\forall x, y, z \in X)(\nu_P(y) \leq \max\{\nu_P(x \cdot ((y \cdot z) \cdot y)), \nu_P(x)\}), \quad (3.1.12)$$

- (6) a *Pythagorean fuzzy shift BCC-filter* of X if it satisfies the conditions (3.1.5) and (3.1.6) and the following conditions:

$$(\forall x, y, z \in X)(\mu_P(((z \cdot y) \cdot y) \cdot z) \geq \min\{\mu_P(x \cdot (y \cdot z)), \mu_P(x)\}), \quad (3.1.13)$$

$$(\forall x, y, z \in X)(\nu_P(((z \cdot y) \cdot y) \cdot z) \leq \max\{\nu_P(x \cdot (y \cdot z)), \nu_P(x)\}). \quad (3.1.14)$$

- (7) a *Pythagorean fuzzy BCC-ideal* of X if it satisfies the conditions (3.1.5) and (3.1.6) and the following conditions:

$$(\forall x, y, z \in X)(\mu_P(x \cdot z) \geq \min\{\mu_P(x \cdot (y \cdot z)), \mu_P(y)\}), \quad (3.1.15)$$

$$(\forall x, y, z \in X)(\nu_P(x \cdot z) \leq \max\{\nu_P(x \cdot (y \cdot z)), \nu_P(y)\}), \quad (3.1.16)$$

- (8) a *Pythagorean fuzzy strong BCC-ideal* of X if it satisfies the conditions

(3.1.5) and (3.1.6) and the following conditions:

$$(\forall x, y, z \in X)(\mu_P(x) \geq \min\{\mu_P((z \cdot y) \cdot (z \cdot x)), \mu_P(y)\}), \quad (3.1.17)$$

$$(\forall x, y, z \in X)(\nu_P(x) \leq \max\{\nu_P((z \cdot y) \cdot (z \cdot x)), \nu_P(y)\}). \quad (3.1.18)$$

Theorem 3.1.2 *A Pythagorean fuzzy set in X is a Pythagorean fuzzy strong BCC-ideal if and only if it is constant.*

Proof. Assume that $P = (\mu_P, \nu_P)$ is a Pythagorean fuzzy strong BCC-ideal of X . Then it satisfies (3.1.5) and (3.1.6). Thus for all $x \in X$,

$$\mu_P(x) \geq \min\{\mu_P((x \cdot 0) \cdot (x \cdot x)), \mu_P(0)\} \quad ((3.1.17))$$

$$= \min\{\mu_P(0 \cdot (x \cdot x)), \mu_P(0)\} \quad ((\text{BCC-3}))$$

$$= \min\{\mu_P(x \cdot x), \mu_P(0)\} \quad ((\text{BCC-2}))$$

$$= \min\{\mu_P(0), \mu_P(0)\} \quad ((2.0.1))$$

$$= \mu_P(0)$$

and

$$\nu_P(x) \leq \max\{\nu_P((x \cdot 0) \cdot (x \cdot x)), \nu_P(0)\} \quad ((3.1.18))$$

$$= \max\{\nu_P(0 \cdot (x \cdot x)), \nu_P(0)\} \quad ((\text{BCC-3}))$$

$$= \max\{\nu_P(x \cdot x), \nu_P(0)\} \quad ((\text{BCC-2}))$$

$$= \max\{\nu_P(0), \nu_P(0)\} \quad ((2.0.1))$$

$$= \nu_P(0).$$

Since $\mu_P(0) \geq \mu_P(x)$ and $\nu_P(0) \leq \nu_P(x)$, we have $\mu_P(x) = \mu_P(0)$ and $\nu_P(x) = \nu_P(0)$ for all $x \in X$. Hence, μ_P and ν_P are constant, that is, P is constant.

The converse is obvious because P is constant. \square

Theorem 3.1.3 *Every Pythagorean fuzzy near BCC-filter of X is a Pythagorean fuzzy BCC-subalgebra.*

Proof. Let $P = (\mu_P, \nu_P)$ be a Pythagorean fuzzy near BCC-filter of X . Then for all $x, y \in X$,

$$\begin{aligned} \mu_P(x \cdot y) &\geq \mu_P(y) \\ &\geq \min\{\mu_P(x), \mu_P(y)\} \end{aligned} \quad ((3.1.3))$$

and

$$\begin{aligned} \nu_P(x \cdot y) &\leq \nu_P(y) \\ &\leq \max\{\nu_P(x), \nu_P(y)\}. \end{aligned} \quad ((3.1.4))$$

Therefore, P is a Pythagorean fuzzy BCC-subalgebra of X . \square

The converse of Theorem 3.1.3 does not hold in general. This is shown by the following example.

Example 3.1.4 Let $X = \{0, 1, 2, 3\}$ be a BCC-algebra with a fixed element 0 and a binary operation \cdot defined by the following Cayley table:

\cdot	0	1	2	3
0	0	1	2	3
1	0	0	1	3
2	0	0	0	3
3	0	1	1	0

We define a Pythagorean fuzzy set $P = (\mu_P, \nu_P)$ with the membership function

μ_P and the non-membership function ν_P as follows:

X	0	1	2	3
μ_P	0.9	0.7	0.8	0.5
ν_P	0	0.4	0.1	0.6

Then P is a Pythagorean fuzzy BCC-subalgebra of X . Since $\mu_P(3 \cdot 2) = \mu_P(1) = 0.7 \not\geq 0.8 = \mu_P(2)$, we have P is not a Pythagorean fuzzy near BCC-filter of X .

Theorem 3.1.5 *Every Pythagorean fuzzy BCC-filter of X is a Pythagorean fuzzy near BCC-filter.*

Proof. Let $P = (\mu_P, \nu_P)$ be a Pythagorean fuzzy BCC-filter of X . Then for all $x, y \in X$,

$$\mu_P(x \cdot y) \geq \min\{\mu_P(y \cdot (x \cdot y)), \mu_P(y)\} \quad ((3.1.7))$$

$$= \min\{\mu_P(0), \mu_P(y)\} \quad ((2.0.5))$$

$$= \mu_P(y)$$

and

$$\nu_P(x \cdot y) \leq \max\{\nu_P(y \cdot (x \cdot y)), \nu_P(y)\} \quad ((3.1.8))$$

$$= \max\{\nu_P(0), \nu_P(y)\} \quad ((2.0.5))$$

$$= \nu_P(y).$$

Therefore, P is a Pythagorean fuzzy near BCC-filter of X . \square

The converse of Theorem 3.1.5 does not hold in general. This is shown by the following example.

Example 3.1.6 Let $X = \{0, 1, 2, 3\}$ be a BCC-algebra with a fixed element 0

and a binary operation \cdot defined by the following Cayley table:

\cdot	0	1	2	3
0	0	1	2	3
1	0	0	2	3
2	0	0	0	3
3	0	0	0	0

We define a Pythagorean fuzzy set $P = (\mu_P, \nu_P)$ with the membership function μ_P and the non-membership function ν_P as follows:

X	0	1	2	3
μ_P	1	0.7	0.8	0.75
ν_P	0	0.6	0.3	0.4

Then P is a Pythagorean fuzzy near BCC-filter of X . Since $\mu_P(1) = 0.7 \not\geq 0.75 = \min\{1, 0.75\} = \min\{\mu_P(0), \mu_P(3)\} = \min\{\mu_P(3 \cdot 1), \mu_P(3)\}$, we have P is not a Pythagorean fuzzy BCC-filter of X .

Theorem 3.1.7 *Every Pythagorean fuzzy implicative BCC-filter of X is a Pythagorean fuzzy BCC-filter.*

Proof. Let $P = (\mu_P, \nu_P)$ be a Pythagorean fuzzy implicative BCC-filter of X . Then for all $x, y \in X$,

$$\mu_P(y) = \mu_P(0 \cdot y) \quad ((\text{BCC-2}))$$

$$\geq \min\{\mu_P(0 \cdot (x \cdot y)), \mu_P(0 \cdot x)\} \quad ((3.1.9))$$

$$= \min\{\mu_P(x \cdot y), \mu_P(x)\} \quad ((\text{BCC-2}))$$

and

$$\nu_P(y) = \nu_P(0 \cdot y) \quad ((\text{BCC-2}))$$

$$\leq \max\{\nu_P(0 \cdot (x \cdot y)), \nu_P(0 \cdot x)\} \quad ((3.1.10))$$

$$= \max\{\nu_P(x \cdot y), \nu_P(x)\}. \quad ((\text{BCC-2}))$$

Therefore, P is a Pythagorean fuzzy BCC-filter of X . \square

The converse of Theorem 3.1.7 does not hold in general. This is shown by the following example.

Example 3.1.8 Let $X = \{0, 1, 2, 3, 4\}$ be a BCC-algebra with a fixed element 0 and a binary operation \cdot defined by the following Cayley table:

\cdot	0	1	2	3	4
0	0	1	2	3	4
1	0	0	2	3	4
2	0	0	0	3	3
3	0	1	2	0	3
4	0	1	2	0	0

We define a Pythagorean fuzzy set $P = (\mu_P, \nu_P)$ with the membership function μ_P and the non-membership function ν_P as follows:

X	0	1	2	3	4
μ_P	0.8	0.7	0.5	0.3	0.3
ν_P	0	0.2	0.3	0.5	0.5

Then P is a Pythagorean fuzzy BCC-filter of X . Since $\mu_P(3 \cdot 4) = \mu_P(3) = 0.3 \not\geq 0.8 = \min\{0.8, 0.8\} = \min\{\mu_P(0), \mu_P(0)\} = \min\{\mu_P(3 \cdot (3 \cdot 4)), \mu_P(3 \cdot 3)\}$, we have P is not a Pythagorean fuzzy implicative BCC-filter of X .

Theorem 3.1.9 *Every Pythagorean fuzzy comparative BCC-filter of X is a Pythagorean fuzzy BCC-filter.*

Proof. Let $P = (\mu_P, \nu_P)$ be a Pythagorean fuzzy comparative BCC-filter of X .

Then for all $x, y \in X$,

$$\mu_P(y) \geq \min\{\mu_P(x \cdot ((y \cdot 0) \cdot y)), \mu_P(x)\} \quad ((3.1.11))$$

$$= \min\{\mu_P(x \cdot (0 \cdot y)), \mu_P(x)\} \quad ((\text{BCC-3}))$$

$$= \min\{\mu_P(x \cdot y), \mu_P(x)\} \quad ((\text{BCC-2}))$$

and

$$\nu_P(y) \leq \max\{\nu_P(x \cdot ((y \cdot 0) \cdot y)), \nu_P(x)\} \quad ((3.1.12))$$

$$= \max\{\nu_P(x \cdot (0 \cdot y)), \nu_P(x)\} \quad ((\text{BCC-3}))$$

$$= \max\{\nu_P(x \cdot y), \nu_P(x)\}. \quad ((\text{BCC-2}))$$

Therefore, P is a Pythagorean fuzzy BCC-filter of X . \square

The converse of Theorem 3.1.9 does not hold in general. This is shown by the following example.

Example 3.1.10 Let $X = \{0, 1, 2, 3, 4\}$ be a BCC-algebra with a fixed element 0 and a binary operation \cdot defined by the following Cayley table:

\cdot	0	1	2	3	4
0	0	1	2	3	4
1	0	0	2	3	4
2	0	0	0	3	4
3	0	0	0	0	4
4	0	1	2	3	0

We define a Pythagorean fuzzy set $P = (\mu_P, \nu_P)$ with the membership function μ_P and the non-membership function ν_P as follows:

X	0	1	2	3	4
μ_P	1	0.6	0.6	0.6	0.4
ν_P	0	0	0.1	0.1	0.4

Then P is a Pythagorean fuzzy BCC-filter of X . Since $\mu_P(2) = 0.6 \not\geq 1 = \min\{1, 1\} = \min\{\mu_P(0), \mu_P(0)\} = \min\{\mu_P(0 \cdot ((2 \cdot 3) \cdot 2)), \mu_P(0)\}$, we have P is not a Pythagorean fuzzy comparative BCC-filter of X .

Theorem 3.1.11 *Every Pythagorean fuzzy shift BCC-filter of X is a Pythagorean fuzzy BCC-filter.*

Proof. Let $P = (\mu_P, \nu_P)$ be a Pythagorean fuzzy shift BCC-filter of X . Then for all $x, y \in X$,

$$\mu_P(y) = \mu_P(0 \cdot y) \quad ((\text{BCC-2}))$$

$$= \mu_P((0 \cdot 0) \cdot y) \quad ((2.0.1))$$

$$= \mu_P(((y \cdot 0) \cdot 0) \cdot y) \quad ((\text{BCC-3}))$$

$$\geq \min\{\mu_P(x \cdot (0 \cdot y)), \mu_P(x)\} \quad ((3.1.13))$$

$$= \min\{\mu_P(x \cdot y), \mu_P(x)\} \quad ((\text{BCC-2}))$$

and

$$\nu_P(y) = \nu_P(0 \cdot y) \quad ((\text{BCC-2}))$$

$$= \nu_P((0 \cdot 0) \cdot y) \quad ((2.0.1))$$

$$= \nu_P(((y \cdot 0) \cdot 0) \cdot y) \quad ((\text{BCC-3}))$$

$$\leq \max\{\nu_P(x \cdot (0 \cdot y)), \nu_P(x)\} \quad ((3.1.14))$$

$$= \max\{\nu_P(x \cdot y), \nu_P(x)\}. \quad ((\text{BCC-2}))$$

Therefore, P is a Pythagorean fuzzy BCC-filter of X . \square

The converse of Theorem 3.1.11 does not hold in general. This is shown by the following example.

Example 3.1.12 Let $X = \{0, 1, 2, 3, 4\}$ be a BCC-algebra with a fixed element 0 and a binary operation \cdot defined by the following Cayley table:

\cdot	0	1	2	3	4
0	0	1	2	3	4
1	0	0	2	2	4
2	0	0	0	2	4
3	0	0	0	0	4
4	0	1	2	3	0

We define a Pythagorean fuzzy set $P = (\mu_P, \nu_P)$ with the membership function μ_P and the non-membership function ν_P as follows:

X	0	1	2	3	4
μ_P	0.9	0.5	0.2	0.2	0.2
ν_P	0.3	0.3	0.4	0.4	0.4

Then P is a Pythagorean fuzzy BCC-filter of X . Since $\mu_P(((1 \cdot 2) \cdot 2) \cdot 1) = \mu_P(1) = 0.5 \not\geq 0.9 = \min\{0.9, 0.9\} = \min\{\mu_P(0), \mu_P(0)\} = \min\{\mu_P(0 \cdot (2 \cdot 1)), \mu_P(0)\}$, we have P is not a Pythagorean fuzzy shift BCC-filter of X .

Theorem 3.1.13 *Every Pythagorean fuzzy implicative BCC-filter of X is a Pythagorean fuzzy BCC-ideal.*

Proof. Let $P = (\mu_P, \nu_P)$ be a Pythagorean fuzzy implicative BCC-filter of X .

By Theorem 3.1.7, we have P is a Pythagorean fuzzy BCC-filter, and so P is a Pythagorean fuzzy near BCC-filter. Then for all $x, y, z \in X$,

$$\mu_P(x \cdot z) \geq \min\{\mu_P(x \cdot (y \cdot z)), \mu_P(x \cdot y)\} \quad ((3.1.9))$$

$$\geq \min\{\mu_P(x \cdot (y \cdot z)), \mu_P(y)\} \quad ((3.1.3))$$

and

$$\nu_P(x \cdot z) \leq \max\{\nu_P(x \cdot (y \cdot z)), \nu_P(x \cdot y)\} \quad ((3.1.10))$$

$$\leq \max\{\nu_P(x \cdot (y \cdot z)), \nu_P(y)\}. \quad ((3.1.4))$$

Therefore, P is a Pythagorean fuzzy BCC-ideal of X . \square

The converse of Theorem 3.1.13 does not hold in general. This is shown by the following example.

Example 3.1.14 Let $X = \{0, 1, 2, 3, 4\}$ be a BCC-algebra with a fixed element 0 and a binary operation \cdot defined by the following Cayley table:

\cdot	0	1	2	3	4
0	0	1	2	3	4
1	0	0	2	3	4
2	0	0	0	3	4
3	0	0	1	0	4
4	0	0	0	0	0

We define a Pythagorean fuzzy set $P = (\mu_P, \nu_P)$ with the membership function

μ_P and the non-membership function ν_P as follows:

X	0	1	2	3	4
μ_P	0.6	0.5	0.2	0.1	0.1
ν_P	0.3	0.4	0.5	0.6	0.8

Then P is a Pythagorean fuzzy BCC-ideal of X . Since $\mu_P(3 \cdot 2) = \mu_P(1) = 0.5 \not\geq 0.6 = \min\{0.6, 0.6\} = \min\{\mu_P(0), \mu_P(0)\} = \min\{\mu_P(3 \cdot (3 \cdot 2)), \mu_P(3 \cdot 3)\}$, we have P is not a Pythagorean fuzzy implicative BCC-filter of X .

Theorem 3.1.15 *Every Pythagorean fuzzy strong BCC-ideal of X is a Pythagorean fuzzy implicative BCC-filter (resp., Pythagorean fuzzy comparative BCC-filter, Pythagorean fuzzy shift BCC-filter).*

Proof. Let $P = (\mu_P, \nu_P)$ be a Pythagorean fuzzy strong BCC-ideal of X . Since P is constant, we have P is a Pythagorean fuzzy implicative BCC-filter (resp., Pythagorean fuzzy comparative BCC-filter, Pythagorean fuzzy shift BCC-filter) of X . \square

The converse of Theorem 3.1.15 does not hold in general. This is shown by the following examples.

Example 3.1.16 Let $X = \{0, 1, 2, 3, 4\}$ be a BCC-algebra with a fixed element 0 and a binary operation \cdot defined by the following Cayley table:

\cdot	0	1	2	3	4
0	0	1	2	3	4
1	0	0	0	0	4
2	0	1	0	0	4
3	0	1	2	0	4
4	0	1	2	3	0

We define a Pythagorean fuzzy set $P = (\mu_P, \nu_P)$ with the membership function μ_P and the non-membership function ν_P as follows:

X	0	1	2	3	4
μ_P	0.5	0.4	0.4	0.4	0.3
ν_P	0.4	0.5	0.5	0.5	0.8

Then P is a Pythagorean fuzzy implicative BCC-filter of X . But P is not a constant Pythagorean fuzzy set of X . Therefore, P is not a Pythagorean fuzzy strong BCC-ideal of X .

Example 3.1.17 Let $X = \{0, 1, 2, 3, 4\}$ be a BCC-algebra with a fixed element 0 and a binary operation \cdot defined by the following Cayley table:

\cdot	0	1	2	3	4
0	0	1	2	3	4
1	0	0	1	2	4
2	0	0	0	2	4
3	0	0	0	0	4
4	0	0	0	2	0

We define a Pythagorean fuzzy set $P = (\mu_P, \nu_P)$ with the membership function μ_P and the non-membership function ν_P as follows:

X	0	1	2	3	4
μ_P	0.9	0.9	0.9	0.9	0.3
ν_P	0.3	0.3	0.3	0.3	0.6

Then P is a Pythagorean fuzzy comparative BCC-filter of X . But P is not a constant Pythagorean fuzzy set of X . Therefore, P is not a Pythagorean fuzzy strong BCC-ideal of X .

Example 3.1.18 Let $X = \{0, 1, 2, 3, 4\}$ be a BCC-algebra with a fixed element 0 and a binary operation \cdot defined by the following Cayley table:

\cdot	0	1	2	3	4
0	0	1	2	3	4
1	0	0	1	2	4
2	0	0	0	1	4
3	0	0	0	0	4
4	0	1	2	3	0

We define a Pythagorean fuzzy set $P = (\mu_P, \nu_P)$ with the membership function μ_P and the non-membership function ν_P as follows:

X	0	1	2	3	4
μ_P	0.5	0.2	0.2	0.2	0.1
ν_P	0.2	0.6	0.6	0.6	0.8

Then P is a Pythagorean fuzzy shift BCC-filter of X . But P is not a constant Pythagorean fuzzy set of X . Therefore, P is not a Pythagorean fuzzy strong BCC-ideal of X .

Theorem 3.1.19 *Every Pythagorean fuzzy BCC-ideal of X is a Pythagorean fuzzy BCC-filter.*

Proof. Let $P = (\mu_P, \nu_P)$ be a Pythagorean fuzzy BCC-ideal of X . It is sufficient to prove the conditions (3.1.7) and (3.1.8). Then for all $x, y \in X$,

$$\mu_P(y) = \mu_P(0 \cdot y) \quad ((\text{BCC-2}))$$

$$\geq \min\{\mu_P(0 \cdot (x \cdot y)), \mu_P(x)\} \quad ((3.1.15))$$

$$= \min\{\mu_P(x \cdot y), \mu_P(x)\} \quad ((\text{BCC-2}))$$

and

$$\nu_P(y) = \nu_P(0 \cdot y) \quad ((\text{BCC-2}))$$

$$\leq \max\{\nu_P(0 \cdot (x \cdot y)), \nu_P(x)\} \quad ((3.1.16))$$

$$= \max\{\nu_P(x \cdot y), \nu_P(x)\}. \quad ((\text{BCC-2}))$$

Therefore, P is a Pythagorean fuzzy BCC-filter of X . \square

The converse of Theorem 3.1.19 does not hold in general. This is shown by the following example.

Example 3.1.20 Let $X = \{0, 1, 2, 3\}$ be a BCC-algebra with a fixed element 0 and a binary operation \cdot defined by the following Cayley table:

\cdot	0	1	2	3
0	0	1	2	3
1	0	0	2	2
2	0	1	0	2
3	0	1	0	0

We define a Pythagorean fuzzy set $P = (\mu_P, \nu_P)$ with the membership function μ_P and the non-membership function ν_P as follows:

X	0	1	2	3
μ_P	0.9	0.5	0.2	0.2
ν_P	0.1	0.4	0.5	0.5

Then P is a Pythagorean fuzzy BCC-filter of X . Since $\mu_P(2 \cdot 3) = \mu_P(2) = 0.2 \not\geq 0.5 = \min\{0.9, 0.5\} = \min\{\mu_P(0), \mu_P(1)\} = \min\{\mu_P(2 \cdot (1 \cdot 3)), \mu_P(1)\}$, we have P is not a Pythagorean fuzzy BCC-ideal of X .

Theorem 3.1.21 *Every Pythagorean fuzzy strong BCC-ideal of X is a Pythagorean fuzzy BCC-ideal.*

Proof. Let $P = (\mu_P, \nu_P)$ be a Pythagorean fuzzy strong BCC-ideal of X . By Theorem 3.1.2, we have P is constant. Therefore, it is obvious that P is a Pythagorean fuzzy BCC-ideal of X . \square

The converse of Theorem 3.1.21 does not hold in general. This is shown by the following example.

Example 3.1.22 Let $X = \{0, 1, 2, 3\}$ be a BCC-algebra with a fixed element 0 and a binary operation \cdot defined by the following Cayley table:

\cdot	0	1	2	3
0	0	1	2	3
1	0	0	2	3
2	0	1	0	3
3	0	1	2	0

We define a Pythagorean fuzzy set $P = (\mu_P, \nu_P)$ with the membership function μ_P and the non-membership function ν_P as follows:

X	0	1	2	3
μ_P	1	0.5	0.2	0.7
ν_P	0	0.6	0.8	0.4

Then P is a Pythagorean fuzzy BCC-ideal of X . But P is not constant and by Theorem 3.1.2, we have P is not a Pythagorean fuzzy strong BCC-ideal of X .

Next, we shall find examples for study connection of Pythagorean fuzzy sets in BCC-algebras.

Example 3.1.23 Let $X = \{0, 1, 2, 3\}$ be a BCC-algebra with a fixed element 0 and a binary operation \cdot defined by the following Cayley table:

\cdot	0	1	2	3
0	0	1	2	3
1	0	0	2	2
2	0	0	0	2
3	0	0	0	0

We define a Pythagorean fuzzy set $P = (\mu_P, \nu_P)$ with the membership function μ_P and the non-membership function ν_P as follows:

X	0	1	2	3
μ_P	0.5	0.2	0.1	0.1
ν_P	0.4	0.7	0.9	0.9

Then P is a Pythagorean fuzzy shift BCC-filter of X . Since $\mu_P(2 \cdot 3) = \mu_P(2) = 0.1 \not\geq 0.5 = \min\{0.5, 0.5\} = \min\{\mu_P(0), \mu_P(0)\} = \min\{\mu_P(2 \cdot (2 \cdot 3)), \mu_P(2 \cdot 2)\}$, we have P is not a Pythagorean fuzzy implicative BCC-filter of X .

Example 3.1.24 From Example 3.1.16, we define a Pythagorean fuzzy set $P = (\mu_P, \nu_P)$ with the membership function μ_P and the non-membership function ν_P as follows:

X	0	1	2	3	4
μ_P	0.8	0.1	0.2	0.6	0.1
ν_P	0.1	0.7	0.6	0.2	0.7

Then P is a Pythagorean fuzzy implicative BCC-filter of X . Since $\nu_P(((2 \cdot 1) \cdot 1) \cdot 2) = \nu_P(2) = 0.6 \not\leq 0.2 = \max\{0.1, 0.2\} = \max\{\nu_P(0), \nu_P(3)\} = \max\{\nu_P(3 \cdot (1 \cdot 2)), \nu_P(3)\}$, we have P is not a Pythagorean fuzzy shift BCC-filter of X .

Example 3.1.25 From Example 3.1.16, we define a Pythagorean fuzzy set $P =$

(μ_P, ν_P) with the membership function μ_P and the non-membership function ν_P as follows:

X	0	1	2	3	4
μ_P	0.5	0.2	0.3	0.4	0.2
ν_P	0.5	0.9	0.8	0.6	0.9

Then P is a Pythagorean fuzzy implicative BCC-filter of X . Since $\nu_P(2) = 0.8 \not\leq 0.6 = \max\{0.5, 0.6\} = \max\{\nu_P(0), \nu_P(3)\} = \max\{\nu_P(3 \cdot ((2 \cdot 1) \cdot 2)), \nu_P(3)\}$, we have P is not a Pythagorean fuzzy comparative BCC-filter of X .

Example 3.1.26 Let $X = \{0, 1, 2, 3, 4\}$ be a BCC-algebra with a fixed element 0 and a binary operation \cdot defined by the following Cayley table:

\cdot	0	1	2	3	4
0	0	1	2	3	4
1	0	0	0	0	0
2	0	1	0	0	4
3	0	1	2	0	4
4	0	1	2	3	0

We define a Pythagorean fuzzy set $P = (\mu_P, \nu_P)$ with the membership function μ_P and the non-membership function ν_P as follows:

X	0	1	2	3	4
μ_P	0.7	0.1	0.4	0.6	0.1
ν_P	0.2	0.7	0.6	0.4	0.7

Then P is a Pythagorean fuzzy BCC-ideal of X . Since $\nu_P(4) = 0.8 \not\leq 0.2 = \max\{0.2, 0.2\} = \max\{\nu_P(0), \nu_P(0)\} = \max\{\nu_P(0 \cdot ((4 \cdot 1) \cdot 4)), \nu_P(0)\}$, we have P is not a Pythagorean fuzzy comparative BCC-filter of X .

Example 3.1.27 Let $X = \{0, 1, 2, 3\}$ be a BCC-algebra with a fixed element 0

and a binary operation \cdot defined by the following Cayley table:

\cdot	0	1	2	3
0	0	1	2	3
1	0	0	2	3
2	0	0	0	3
3	0	0	0	0

We define a Pythagorean fuzzy set $P = (\mu_P, \nu_P)$ with the membership function μ_P and the non-membership function ν_P as follows:

X	0	1	2	3
μ_P	0.6	0.4	0.2	0.2
ν_P	0.3	0.5	0.9	0.9

Then P is a Pythagorean fuzzy BCC-ideal of X . Since $\nu_P(((1 \cdot 2) \cdot 2) \cdot 1) = \nu_P(1) = 0.5 \not\leq 0.3 = \max\{0.3, 0.3\} = \max\{\nu_P(0), \nu_P(0)\} = \max\{\nu_P(0 \cdot (2 \cdot 1)), \nu_P(0)\}$, we have P is not a Pythagorean fuzzy shift BCC-filter of X .

Example 3.1.28 From Example 3.1.23, we define a Pythagorean fuzzy set $P = (\mu_P, \nu_P)$ with the membership function μ_P and the non-membership function ν_P as follows:

X	0	1	2	3
μ_P	0.7	0.7	0.4	0.4
ν_P	0.5	0.5	0.6	0.6

Then P is a Pythagorean fuzzy shift BCC-filter of X . Since $\nu_P(2 \cdot 3) = \nu_P(2) = 0.6 \not\leq 0.5 = \max\{0.5, 0.5\} = \max\{\nu_P(0), \nu_P(1)\} = \max\{\nu_P(2 \cdot (1 \cdot 3)), \nu_P(1)\}$, we have P is not a Pythagorean fuzzy BCC-ideal of X .

Example 3.1.29 From Example 3.1.23, we define a Pythagorean fuzzy set $P = (\mu_P, \nu_P)$ with the membership function μ_P and the non-membership function ν_P

as follows:

X	0	1	2	3
μ_P	0.5	0.5	0.1	0.1
ν_P	0.6	0.6	0.8	0.8

Then P is a Pythagorean fuzzy shift BCC-filter of X . Since $\nu_P(2) = 0.8 \not\leq 0.6 = \max\{0.6, 0.6\} = \max\{\nu_P(0), \nu_P(0)\} = \max\{\nu_P(0 \cdot ((2 \cdot 3) \cdot 2)), \nu_P(0)\}$, we have P is not a Pythagorean fuzzy comparative BCC-filter of X .

We get the diagram of the generalization of Pythagorean fuzzy sets in BCC-algebras, which is shown with Figure 1

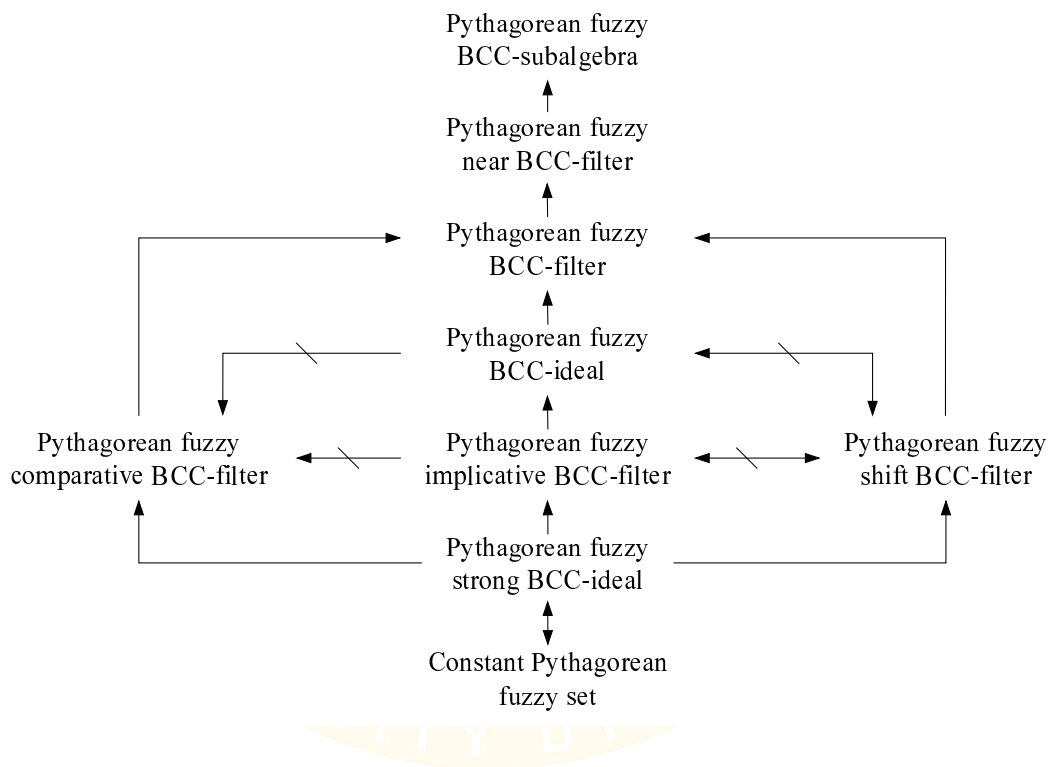

Figure 1: Pythagorean fuzzy sets in BCC-algebras

If F is a fuzzy set in X , then $(f_F, f_{\bar{F}})$ is a Pythagorean fuzzy set in X .
Indeed, for all $x \in X$,

$$\begin{aligned}
 0 &\leq (f_F(x))^2 + (f_{\bar{F}}(x))^2 \\
 &= (f_F(x))^2 + (1 - f_F(x))^2 \\
 &\leq f_F(x) + 1 - 2f_F(x) + (f_F(x))^2 \\
 &\leq f_F(x) + 1 - 2f_F(x) + f_F(x) \\
 &= 1.
 \end{aligned}$$

Theorem 3.1.30 *Let F be a fuzzy set in X . Then the following statements hold:*

- (1) $(f_F, f_{\bar{F}})$ is a Pythagorean fuzzy set in X ,
- (2) F is a fuzzy BCC-subalgebra of X if and only if $(f_F, f_{\bar{F}})$ is a Pythagorean fuzzy BCC-subalgebra of X ,
- (3) F is a fuzzy near BCC-filter of X if and only if $(f_F, f_{\bar{F}})$ is a Pythagorean fuzzy near BCC-filter of X ,
- (4) F is a fuzzy BCC-filter of X if and only if $(f_F, f_{\bar{F}})$ is a Pythagorean fuzzy BCC-filter of X ,
- (5) F is a fuzzy implicative BCC-filter of X if and only if $(f_F, f_{\bar{F}})$ is a Pythagorean fuzzy implicative BCC-filter of X ,
- (6) F is a fuzzy comparative BCC-filter of X if and only if $(f_F, f_{\bar{F}})$ is a Pythagorean fuzzy comparative BCC-filter of X ,
- (7) F is a fuzzy shift BCC-filter of X if and only if $(f_F, f_{\bar{F}})$ is a Pythagorean fuzzy shift BCC-filter of X .
- (8) F is a fuzzy BCC-ideal of X if and only if $(f_F, f_{\bar{F}})$ is a Pythagorean fuzzy BCC-ideal of X , and

(9) F is a fuzzy strong BCC-ideal of X if and only if $(f_F, f_{\bar{F}})$ is a Pythagorean fuzzy strong BCC-ideal of X .

Proof. (1) Let $x \in X$. Then $0 \leq f_F(x)^2 + f_{\bar{F}}(x)^2 = f_F(x)^2 + (1 - f_F(x))^2 \leq f_F(x) + (1 - f_F(x)) = 1$. Hence, $(f_F, f_{\bar{F}})$ is a Pythagorean fuzzy set in X .

(2) Assume that F is a fuzzy BCC-subalgebra of X . Then for all $x, y \in X$,

$$f_F(x \cdot y) \geq \min\{f_F(x), f_F(y)\} \quad ((2.0.27))$$

and

$$\begin{aligned} f_{\bar{F}}(x \cdot y) &= 1 - f_F(x \cdot y) \\ &\leq 1 - \min\{f_F(x), f_F(y)\} \\ &= \max\{f_{\bar{F}}(x), f_{\bar{F}}(y)\}. \end{aligned} \quad \begin{array}{l} ((2.0.27)) \\ \text{(Proposition 2.0.9 (4))} \end{array}$$

This implies that $(f_F, f_{\bar{F}})$ is a Pythagorean fuzzy BCC-subalgebra of X .

Conversely, assume that $(f_F, f_{\bar{F}})$ is a Pythagorean fuzzy BCC-subalgebra of X . Then F satisfies the condition (3.1.1). Hence, F is a fuzzy BCC-subalgebra of X .

(3) Assume that F is a fuzzy near BCC-filter of X . Then for all $x, y \in X$,

$$f_F(x \cdot y) \geq f_F(y) \quad ((2.0.26))$$

and

$$f_{\bar{F}}(x \cdot y) \leq f_{\bar{F}}(y). \quad \text{(Proposition 2.0.9 (1))}$$

This implies that $(f_F, f_{\bar{F}})$ is a Pythagorean fuzzy near BCC-filter of X .

Conversely, assume that $(f_F, f_{\tilde{F}})$ is a Pythagorean fuzzy near BCC-filter of X . Then F satisfies the condition (3.1.3). Hence, F is a fuzzy near BCC-filter of X .

(4) Assume that F is a fuzzy BCC-filter of X . Then for all $x, y \in X$,

$$f_F(0) \geq f_F(x), \quad ((2.0.28))$$

$$f_{\tilde{F}}(0) \leq f_{\tilde{F}}(x), \quad (\text{Proposition 2.0.9 (1)})$$

$$f_F(y) \geq \min\{f_F(x \cdot y), f_F(x)\}, \quad ((2.0.29))$$

and

$$\begin{aligned} f_{\tilde{F}}(y) &= 1 - f_F(y) \\ &\leq 1 - \min\{f_F(x \cdot y), f_F(x)\} \\ &= \max\{f_{\tilde{F}}(x \cdot y), f_{\tilde{F}}(x)\}. \end{aligned} \quad ((2.0.29)) \quad (\text{Proposition 2.0.9 (4)})$$

This implies that $(f_F, f_{\tilde{F}})$ is a Pythagorean fuzzy BCC-filter of X .

Conversely, assume that $(f_F, f_{\tilde{F}})$ is a Pythagorean fuzzy BCC-filter of X . Then F satisfies the conditions (3.1.5) and (3.1.7). Hence, F is a fuzzy BCC-filter of X .

(5) Assume that F is a fuzzy implicative BCC-filter of X . Then for all $x, y \in X$,

$$f_F(0) \geq f_F(x), \quad ((2.0.28))$$

$$f_{\tilde{F}}(0) \leq f_{\tilde{F}}(x), \quad (\text{Proposition 2.0.9 (1)})$$

$$f_F(x \cdot z) \geq \min\{f_F(x \cdot (y \cdot z)), f_F(x \cdot y)\}, \quad ((2.0.30))$$

and

$$\begin{aligned} f_{\tilde{F}}(x \cdot z) &= 1 - f_F(x \cdot z) \\ &\leq 1 - \min\{f_F(x \cdot (y \cdot z)), f_F(x \cdot y)\} \quad ((2.0.30)) \\ &= \max\{f_{\tilde{F}}(x \cdot (y \cdot z)), f_{\tilde{F}}(x \cdot y)\}. \quad (\text{Proposition 2.0.9 (4)}) \end{aligned}$$

This implies that $(f_F, f_{\tilde{F}})$ is a Pythagorean fuzzy implicative BCC-filter of X .

Conversely, assume that $(f_F, f_{\tilde{F}})$ is a Pythagorean fuzzy implicative BCC-filter of X . Then F satisfies the conditions (3.1.5) and (3.1.9). Hence, F is a fuzzy implicative BCC-filter of X .

(6) Assume that F is a fuzzy comparative BCC-filter of X . Then for all $x, y \in X$,

$$f_F(0) \geq f_F(x), \quad ((2.0.28))$$

$$f_{\tilde{F}}(0) \leq f_{\tilde{F}}(x), \quad (\text{Proposition 2.0.9 (1)})$$

$$f_F(y) \geq \min\{f_F(x \cdot ((y \cdot z) \cdot y)), f_F(x)\}, \quad ((2.0.31))$$

and

$$\begin{aligned} f_{\tilde{F}}(y) &= 1 - f_F(y) \\ &\leq 1 - \min\{f_F(x \cdot ((y \cdot z) \cdot y)), f_F(x)\} \quad ((2.0.31)) \\ &= \max\{f_{\tilde{F}}(x \cdot ((y \cdot z) \cdot y)), f_{\tilde{F}}(x)\}. \quad (\text{Proposition 2.0.9 (4)}) \end{aligned}$$

This implies that $(f_F, f_{\tilde{F}})$ is a Pythagorean fuzzy comparative BCC-filter of X .

Conversely, assume that $(f_F, f_{\bar{F}})$ is a Pythagorean fuzzy comparative BCC-filter of X . Then F satisfies the conditions (3.1.5) and (3.1.11). Hence, F is a fuzzy comparative BCC-filter of X .

(7) Assume that F is a fuzzy shift BCC-filter of X . Then for all $x, y \in X$,

$$f_F(0) \geq f_F(x), \quad ((2.0.28))$$

$$f_{\bar{F}}(0) \leq f_{\bar{F}}(x), \quad (\text{Proposition 2.0.9 (1)})$$

$$f_F(((z \cdot y) \cdot y) \cdot z) \geq \min\{f_F(x \cdot (y \cdot z)), f_F(x)\}, \quad ((2.0.32))$$

and

$$\begin{aligned} f_{\bar{F}}(((z \cdot y) \cdot y) \cdot z) &= 1 - f_F(((z \cdot y) \cdot y) \cdot z) \\ &\leq 1 - \min\{f_F(x \cdot (y \cdot z)), f_F(x)\} \quad ((2.0.32)) \\ &= \max\{f_{\bar{F}}(x \cdot (y \cdot z)), f_{\bar{F}}(x)\}. \quad (\text{Proposition 2.0.9 (4)}) \end{aligned}$$

This implies that $(f_F, f_{\bar{F}})$ is a Pythagorean fuzzy shift BCC-filter of X .

Conversely, assume that $(f_F, f_{\bar{F}})$ is a Pythagorean fuzzy shift BCC-filter of X . Then F satisfies the conditions (3.1.5) and (3.1.13). Hence, F is a fuzzy shift BCC-filter of X .

(8) Assume that F is a fuzzy BCC-ideal of X . Then for all $x, y \in X$,

$$f_F(0) \geq f_F(x), \quad ((2.0.28))$$

$$f_{\bar{F}}(0) \leq f_{\bar{F}}(x), \quad (\text{Proposition 2.0.9 (1)})$$

$$f_F(x \cdot z) \geq \min\{f_F(x \cdot (y \cdot z)), f_F(y)\}, \quad ((2.0.33))$$

and

$$\begin{aligned}
f_{\bar{F}}(x \cdot z) &= 1 - f_F(x \cdot z) \\
&\leq 1 - \min\{f_F(x \cdot (y \cdot z)), f_F(y)\} && ((2.0.33)) \\
&= \max\{f_{\bar{F}}(x \cdot (y \cdot z)), f_{\bar{F}}(y)\}. && (\text{Proposition 2.0.9 (4)})
\end{aligned}$$

This implies that $(f_F, f_{\bar{F}})$ is a Pythagorean fuzzy BCC-ideal of X .

Conversely, assume that $(f_F, f_{\bar{F}})$ is a Pythagorean fuzzy BCC-ideal of X . Then F satisfies the conditions (3.1.5) and (3.1.15). Hence, F is a fuzzy BCC-ideal of X .

(9) Assume that F is a fuzzy strong BCC-ideal of X . Then f_F is constant and so $f_{\bar{F}}$ is constant. By Theorem 3.1.2, we have $(f_F, f_{\bar{F}})$ is a Pythagorean fuzzy strong BCC-ideal of X .

Conversely, assume that $(f_F, f_{\bar{F}})$ is a Pythagorean fuzzy strong BCC-ideal of X . By Theorem 3.1.2, we have f_F is constant. Hence, F is a fuzzy strong BCC-ideal of X . \square

3.2 Properties of Pythagorean fuzzy sets

In this section, we shall find some properties and examples for study the generalizations of Pythagorean fuzzy sets in BCC-algebras.

Proposition 3.2.1 *If $P = (\mu_P, \nu_P)$ is a Pythagorean fuzzy BCC-subalgebra of X , then it satisfies the conditions (3.1.5) and (3.1.6).*

Proof. Let $P = (\mu_P, \nu_P)$ be a Pythagorean fuzzy BCC-subalgebra of X . Then for all $x \in X$,

$$\mu_P(0) = \mu_P(x \cdot x) \geq \min\{\mu_P(x), \mu_P(x)\} = \mu_P(x) \quad ((2.0.1) \text{ and } (3.1.1))$$

and

$$\nu_P(0) = \nu_P(x \cdot x) \leq \max\{\nu_P(x), \nu_P(x)\} = \nu_P(x). \quad ((2.0.1) \text{ and } (3.1.2))$$

□

Proposition 3.2.2 *If $P = (\mu_P, \nu_P)$ is a Pythagorean fuzzy BCC-filter of X , then*

$$(\forall x, y \in X) \begin{pmatrix} x \leq y \Rightarrow \mu_P(x) \leq \mu_P(y), \\ x \leq y \Rightarrow \nu_P(x) \geq \nu_P(y) \end{pmatrix}, \quad (3.2.1)$$

Proof. Let $P = (\mu_P, \nu_P)$ be a Pythagorean fuzzy BCC-filter of X and let $x, y \in X$ be such that $x \leq y$. Then $x \cdot y = 0$, so

$$\mu_P(y) \geq \min\{\mu_P(x \cdot y), \mu_P(x)\} = \min\{\mu_P(0), \mu_P(x)\} = \mu_P(x) \quad ((3.1.7))$$

and

$$\nu_P(y) \leq \max\{\nu_P(x \cdot y), \nu_P(x)\} = \max\{\nu_P(0), \nu_P(x)\} = \nu_P(x). \quad ((3.1.8))$$

□

Corollary 3.2.3 *If $P = (\mu_P, \nu_P)$ is a Pythagorean fuzzy BCC-filter of X , then*

$$(\forall x, y \in X) \begin{pmatrix} \mu_P(y) \leq \mu_P(x \cdot y), \\ \nu_P(y) \geq \nu_P(x \cdot y) \end{pmatrix}, \quad (3.2.2)$$

Proof. By (2.0.5), we have $y \cdot (x \cdot y) = 0$, that is, $y \leq x \cdot y$. By (3.2.1), we have $\mu_P(y) \leq \mu_P(x \cdot y)$ and $\nu_P(y) \geq \nu_P(x \cdot y)$. □

Proposition 3.2.4 *If $P = (\mu_P, \nu_P)$ is a Pythagorean fuzzy set in X satisfying the*

following conditions:

$$(\forall x, y, z \in X) \left(\begin{array}{l} z \leq x \Rightarrow \mu_P(x \cdot y) \geq \min\{\mu_P(z), \mu_P(y)\}, \\ z \leq x \Rightarrow \nu_P(x \cdot y) \leq \max\{\nu_P(z), \nu_P(y)\} \end{array} \right), \quad (3.2.3)$$

then it is a Pythagorean fuzzy BCC-subalgebra of X .

Proof. Let $x, y \in X$. By (2.0.1), we have $x \leq x$. It follows from (3.2.3) that $\mu_P(x \cdot y) \geq \min\{\mu_P(x), \mu_P(y)\}$ and $\nu_P(x \cdot y) \leq \max\{\nu_P(x), \nu_P(y)\}$. Hence, P is a Pythagorean fuzzy BCC-subalgebra of X . \square

Theorem 3.2.5 *If $P = (\mu_P, \nu_P)$ is a Pythagorean fuzzy set in X satisfying the condition (3.2.3), then it satisfies the conditions (3.1.5) and (3.1.6).*

Proof. It is straightforward by Proposition 3.2.4. \square

In general, the converse of Theorem 3.2.5 may be not true by the following example.

Example 3.2.6 From Example 3.1.20, we define a Pythagorean fuzzy set $P = (\mu_P, \nu_P)$ with the membership function μ_P and the non-membership function ν_P as follows:

X	0	1	2	3
μ_P	1	0.5	0.1	0.7
ν_P	0	0.5	0.6	0.4

Then P satisfies the conditions (3.1.5) and (3.1.6) but it does not satisfy the condition (3.2.3). Indeed, $1 \leq 1$ but $\mu_P(1 \cdot 3) = \mu_P(2) = 0.1 \not\geq 0.5 = \min\{0.5, 0.7\} = \min\{\mu_P(1), \mu_P(3)\}$ and $\nu_P(1 \cdot 3) = \nu_P(2) = 0.6 \not\leq 0.5 = \max\{0.5, 0.4\} = \max\{\nu_P(1), \nu_P(3)\}$.

Proposition 3.2.7 *If $P = (\mu_P, \nu_P)$ is a Pythagorean fuzzy set in X satisfying the*

following conditions:

$$(\forall x, y, z \in X) \left(\begin{array}{l} \mu_P(x \cdot y) \geq \min\{\mu_P(z), \mu_P(y)\}, \\ \nu_P(x \cdot y) \leq \max\{\nu_P(z), \nu_P(y)\} \end{array} \right), \quad (3.2.4)$$

then it satisfies the condition (3.2.3).

In general, the converse of Proposition 3.2.7 may be not true by the following example.

Example 3.2.8 Let $X = \{0, 1, 2, 3\}$ be a BCC-algebra with a fixed element 0 and a binary operation \cdot defined by the following Cayley table:

\cdot	0	1	2	3
0	0	1	2	3
1	0	0	3	3
2	0	1	0	0
3	0	1	2	0

We define a Pythagorean fuzzy set $P = (\mu_P, \nu_P)$ with the membership function μ_P and the non-membership function ν_P as follows:

X	0	1	2	3
μ_P	0.8	0.1	0.3	0.2
ν_P	0.4	0.9	0.6	0.8

Then P satisfies the condition (3.2.3) but it does not satisfy the condition (3.2.4).

Indeed, $\mu_P(1 \cdot 2) = \mu_P(3) = 0.2 \not\geq 0.3 = \min\{0.8, 0.3\} = \min\{\mu_P(0), \mu_P(2)\}$ and $\nu_P(1 \cdot 2) = \nu_P(3) = 0.8 \not\leq 0.6 = \max\{0.4, 0.6\} = \max\{\nu_P(0), \nu_P(2)\}$.

Proposition 3.2.9 If $P = (\mu_P, \nu_P)$ is a Pythagorean fuzzy set in X satisfying the

condition (3.2.1), then it is a Pythagorean fuzzy near BCC-filter of X .

Proof. Let $x, y \in X$. By (2.0.5), we have $y \leq x \cdot y$. It follows from (3.2.1) that $\mu_P(x \cdot y) \geq \mu_P(y)$ and $\nu_P(x \cdot y) \leq \nu_P(y)$. Hence, P is a Pythagorean fuzzy near BCC-filter of X . \square

Theorem 3.2.10 *If $P = (\mu_P, \nu_P)$ is a Pythagorean fuzzy set in X satisfying the condition (3.2.1), then it satisfies the condition (3.2.4).*

Proof. Let $x, y, z \in X$. By (2.0.5), we have $y \leq x \cdot y$. It follows from (3.2.1) that $\mu_P(x \cdot y) \geq \mu_P(y) \geq \min\{\mu_P(z), \mu_P(y)\}$ and $\nu_P(x \cdot y) \leq \nu_P(y) \leq \max\{\nu_P(z), \nu_P(y)\}$. \square

In general, the converse of Theorem 3.2.10 may be not true by the following example.

Example 3.2.11 From Example 3.1.6, we define a Pythagorean fuzzy set $P = (\mu_P, \nu_P)$ with the membership function μ_P and the non-membership function ν_P as follows:

X	0	1	2	3
μ_P	0.8	0.3	0.4	0.7
ν_P	0.2	0.7	0.5	0.4

Then P satisfies the condition (3.2.4) but it does not satisfy the condition (3.2.1). Indeed, $3 \leq 1$ but $\mu_P(3) = 0.7 \not\geq 0.3 = \mu_P(1)$ and $\nu_P(3) = 0.4 \not\leq 0.7 = \nu_P(1)$.

Theorem 3.2.12 *If $P = (\mu_P, \nu_P)$ is a Pythagorean fuzzy BCC-subalgebra of X satisfying the following conditions:*

$$(\forall x, y, z \in X) \left(\begin{array}{l} x \cdot y \neq 0 \Rightarrow \mu_P(x) \geq \mu_P(y), \\ x \cdot y \neq 0 \Rightarrow \nu_P(x) \leq \nu_P(y) \end{array} \right), \quad (3.2.5)$$

then it is a Pythagorean fuzzy near BCC-filter of X .

Proof. Let $x, y \in X$.

Case 1: $x \cdot y = 0$. By Proposition 3.2.1, we have $\mu_P(x \cdot y) = \mu_P(0) \geq \mu_P(y)$ and $\nu_P(x \cdot y) = \nu_P(0) \leq \nu_P(y)$.

Case 2: $x \cdot y \neq 0$. By (3.2.5), we have $\mu_P(x \cdot y) \geq \min\{\mu_P(x), \mu_P(y)\} = \mu_P(y)$ and $\nu_P(x \cdot y) \leq \max\{\nu_P(x), \nu_P(y)\} = \nu_P(y)$. Hence, P is a Pythagorean fuzzy near BCC-filter of X . \square

Proposition 3.2.13 *A Pythagorean fuzzy set $P = (\mu_P, \nu_P)$ in X satisfies the following conditions:*

$$(\forall x, y, z \in X) \left(\begin{array}{l} z \leq x \cdot y \Rightarrow \mu_P(y) \geq \min\{\mu_P(z), \mu_P(x)\}, \\ z \leq x \cdot y \Rightarrow \nu_P(y) \leq \max\{\nu_P(z), \nu_P(x)\} \end{array} \right), \quad (3.2.6)$$

if and only if it is a Pythagorean fuzzy BCC-filter of X .

Proof. Let $x \in X$. By (BCC-3), we have $x \leq x \cdot 0$. It follows from (3.2.6) that $\mu_P(0) \geq \min\{\mu_P(x), \mu_P(x)\} = \mu_P(x)$ and $\nu_P(0) \leq \max\{\nu_P(x), \nu_P(x)\} = \nu_P(x)$. Next, let $x, y \in X$. By (2.0.1), we have $x \cdot y \leq x \cdot y$. It follows from (3.2.6) that $\mu_P(y) \geq \min\{\mu_P(x \cdot y), \mu_P(x)\}$ and $\nu_P(y) \leq \max\{\nu_P(x \cdot y), \nu_P(x)\}$. Hence, P is a Pythagorean fuzzy BCC-filter of X .

Conversely, let $x, y, z \in X$ be such that $z \leq x \cdot y$. Then $z \cdot (x \cdot y) = 0$, so

$$\mu_P(x \cdot y) \geq \min\{\mu_P(z \cdot (x \cdot y)), \mu_P(z)\} = \min\{\mu_P(0), \mu_P(z)\} = \mu_P(z) \quad ((3.1.7))$$

and

$$\nu_P(x \cdot y) \leq \max\{\nu_P(z \cdot (x \cdot y)), \nu_P(z)\} = \max\{\nu_P(0), \nu_P(z)\} = \nu_P(z). \quad ((3.1.8))$$

Thus

$$\mu_P(y) \geq \min\{\mu_P(x \cdot y), \mu_P(x)\} \geq \min\{\mu_P(z), \mu_P(x)\}$$

and

$$\nu_P(y) \leq \max\{\nu_P(x \cdot y), \nu_P(x)\} \leq \max\{\nu_P(z), \nu_P(x)\}.$$

□

Theorem 3.2.14 *If $P = (\mu_P, \nu_P)$ is a Pythagorean fuzzy set in X satisfying the condition (3.2.6), then it satisfies the condition (3.2.1).*

Proof. Let $x, y \in X$ be such that $x \leq y$. By (2.0.11), we have $x \leq x \cdot y$. It follows from (3.2.6) that $\mu_P(y) \geq \min\{\mu_P(x), \mu_P(x)\} = \mu_P(x)$ and $\nu_P(y) \leq \max\{\nu_P(x), \nu_P(x)\} = \nu_P(x)$. □

In general, the converse of Theorem 3.2.14 may be not true by the following example.

Example 3.2.15 Let $X = \{0, 1, 2, 3\}$ be a BCC-algebra with a fixed element 0 and a binary operation \cdot defined by the following Cayley table:

\cdot	0	1	2	3
0	0	1	2	3
1	0	0	2	2
2	0	1	0	1
3	0	0	0	0

We define a Pythagorean fuzzy set $P = (\mu_P, \nu_P)$ with the membership function

μ_P and the non-membership function ν_P as follows:

X	0	1	2	3
μ_P	0.7	0.3	0.5	0.1
ν_P	0.3	0.7	0.5	0.8

Then P satisfies the condition (3.2.1) but it does not satisfy the condition (3.2.6). Indeed, $2 \leq 1 \cdot 3$ but $\mu_P(3) = 0.1 \not\geq 0.3 = \min\{0.5, 0.3\} = \min\{\mu_P(2), \mu_P(1)\}$ and $\nu_P(3) = 0.8 \not\leq 0.7 = \max\{0.5, 0.7\} = \max\{\nu_P(2), \nu_P(1)\}$.

Theorem 3.2.16 *If $P = (\mu_P, \nu_P)$ is a Pythagorean fuzzy near BCC-filter of X satisfying the following conditions:*

$$(\forall x, y \in X) \begin{pmatrix} \mu_P(x \cdot y) = \mu_P(y), \\ \nu_P(x \cdot y) = \nu_P(y) \end{pmatrix}, \quad (3.2.7)$$

then it is a Pythagorean fuzzy BCC-filter of X .

Proof. Let $x, y \in X$. By Theorem 3.1.3 and Proposition 3.2.1, we have P is a Pythagorean fuzzy BCC-subalgebra of X which satisfies the conditions (3.1.5) and (3.1.6). By (3.2.7), we have $\mu_P(y) \geq \min\{\mu_P(y), \mu_P(x)\} = \min\{\mu_P(x \cdot y), \mu_P(x)\}$ and $\nu_P(y) \leq \max\{\nu_P(y), \nu_P(x)\} = \max\{\nu_P(x \cdot y), \nu_P(x)\}$. Hence, P is a Pythagorean fuzzy BCC-filter of X . \square

Theorem 3.2.17 *If P is a Pythagorean fuzzy BCC-ideal of X satisfying the following condition:*

$$(\forall x, y, z \in X) \begin{pmatrix} \mu_P(x \cdot (y \cdot z)) \geq \mu_P(y) \Rightarrow \mu_P(y) \geq \mu_P(x \cdot y), \\ \nu_P(x \cdot (y \cdot z)) \leq \nu_P(y) \Rightarrow \nu_P(y) \leq \nu_P(x \cdot y) \end{pmatrix}, \quad (3.2.8)$$

then P is a Pythagorean fuzzy implicative BCC-filter of X .

Proof. Let $P = (\mu_P, \nu_P)$ be a Pythagorean fuzzy BCC-ideal of X satisfying the

condition (3.2.8). Then P satisfies the conditions (3.1.5) and (3.1.6). In case of $\mu_P(x \cdot (y \cdot z)) < \mu_P(y)$ and $\nu_P(x \cdot (y \cdot z)) > \nu_P(y)$ are easy to verify. Next, let $x, y, z \in X$,

$$\mu_P(x \cdot z) \geq \min\{\mu_P(x \cdot (y \cdot z)), \mu_P(y)\} \quad ((3.1.15))$$

$$\geq \min\{\mu_P(x \cdot (y \cdot z)), \mu_P(x \cdot y)\} \quad ((3.2.8) \text{ for } \mu_P)$$

and

$$\nu_P(x \cdot z) \leq \max\{\nu_P(x \cdot (y \cdot z)), \nu_P(y)\} \quad ((3.1.16))$$

$$\leq \max\{\nu_P(x \cdot (y \cdot z)), \nu_P(x \cdot y)\}. \quad ((3.2.8) \text{ for } \nu_P)$$

Therefore, P is a Pythagorean fuzzy implicative BCC-filter of X . \square

Theorem 3.2.18 *If P is a Pythagorean fuzzy BCC-ideal of X satisfying the following condition:*

$$(\forall x, y, z \in X) \left(\begin{array}{l} \mu_P(x \cdot y) \geq \mu_P(x \cdot ((x \cdot y) \cdot z)) \\ \Rightarrow \mu_P(x \cdot ((x \cdot y) \cdot z)) \geq \mu_P(x \cdot (y \cdot z)), \\ \nu_P(x \cdot y) \leq \nu_P(x \cdot ((x \cdot y) \cdot z)) \\ \Rightarrow \nu_P(x \cdot ((x \cdot y) \cdot z)) \leq \nu_P(x \cdot (y \cdot z)) \end{array} \right), \quad (3.2.9)$$

then P is a Pythagorean fuzzy implicative BCC-filter of X .

Proof. Let $P = (\mu_P, \nu_P)$ be a Pythagorean fuzzy BCC-ideal of X satisfying the condition (3.2.9). Then P satisfies the conditions (3.1.5) and (3.1.6). In case of $\mu_P(x \cdot y) < \mu_P(x \cdot ((x \cdot y) \cdot z))$ and $\nu_P(x \cdot y) > \nu_P(x \cdot ((x \cdot y) \cdot z))$ are easy to verify. Next, let $x, y, z \in X$,

$$\mu_P(x \cdot z) \geq \min\{\mu_P(x \cdot ((x \cdot y) \cdot z)), \mu_P(x \cdot y)\} \quad ((3.1.15))$$

$$\geq \min\{\mu_P(x \cdot (y \cdot z)), \mu_P(x \cdot y)\} \quad ((3.2.9) \text{ for } \mu_P)$$

and

$$\nu_P(x \cdot z) \leq \max\{\nu_P((x \cdot y) \cdot z), \nu_P(x \cdot y)\} \quad ((3.1.16))$$

$$\leq \max\{\nu_P(x \cdot (y \cdot z)), \nu_P(x \cdot y)\}. \quad ((3.2.9) \text{ for } \nu_P)$$

Therefore, P is a Pythagorean fuzzy implicative BCC-filter of X . \square

Theorem 3.2.19 *If P is a Pythagorean fuzzy BCC-filter of X satisfying the following condition:*

$$(\forall x, y, z \in X) \left(\begin{array}{l} \mu_P(x) \geq \mu_P(x \cdot y) \\ \Rightarrow \mu_P(x \cdot y) \geq \mu_P(x \cdot ((y \cdot z) \cdot y)), \\ \nu_P(x) \leq \nu_P(x \cdot y) \\ \Rightarrow \nu_P(x \cdot y) \leq \nu_P(x \cdot ((y \cdot z) \cdot y)) \end{array} \right), \quad (3.2.10)$$

then P is a Pythagorean fuzzy comparative BCC-filter of X .

Proof. Let $P = (\mu_P, \nu_P)$ be a Pythagorean fuzzy BCC-filter of X satisfying the condition (3.2.10). Then P satisfies the conditions (3.1.5) and (3.1.6). In case of $\mu_P(x) < \mu_P(x \cdot y)$ and $\nu_P(x) > \nu_P(x \cdot y)$ are easy to verify. Next, let $x, y, z \in X$,

$$\mu_P(y) \geq \min\{\mu_P(x \cdot y), \mu_P(x)\} \quad ((3.1.7))$$

$$\geq \min\{\mu_P(x \cdot ((y \cdot z) \cdot y)), \mu_P(x)\} \quad ((3.2.10) \text{ for } \mu_P)$$

and

$$\nu_P(y) \leq \max\{\nu_P(x \cdot y), \nu_P(x)\} \quad ((3.1.8))$$

$$\leq \max\{\nu_P(x \cdot ((y \cdot z) \cdot y)), \nu_P(x)\}. \quad ((3.2.10) \text{ for } \nu_P)$$

Therefore, P is a Pythagorean fuzzy comparative BCC-filter of X . \square

Theorem 3.2.20 *If P is a Pythagorean fuzzy BCC-filter of X satisfying the following condition:*

$$(\forall x, y, z \in X) \left(\begin{array}{l} \mu_P(x) \geq \mu_P(x \cdot ((z \cdot y) \cdot y) \cdot z) \\ \Rightarrow \mu_P(x \cdot ((z \cdot y) \cdot y) \cdot z) \geq \mu_P(x \cdot (y \cdot z)), \\ \nu_P(x) \leq \nu_P(x \cdot ((z \cdot y) \cdot y) \cdot z) \\ \Rightarrow \nu_P(x \cdot ((z \cdot y) \cdot y) \cdot z) \leq \nu_P(x \cdot (y \cdot z)) \end{array} \right), \quad (3.2.11)$$

then P is a Pythagorean fuzzy shift BCC-filter of X .

Proof. Let $P = (\mu_P, \nu_P)$ be a Pythagorean fuzzy BCC-filter of X satisfying the condition (3.2.11). Then P satisfies the conditions (3.1.5) and (3.1.6). In case of $\mu_P(x) < \mu_P(x \cdot ((z \cdot y) \cdot y) \cdot z)$ and $\nu_P(x) > \nu_P(x \cdot ((z \cdot y) \cdot y) \cdot z)$ are easy to verify. Next, let $x, y, z \in X$,

$$\mu_P(((z \cdot y) \cdot y) \cdot z) \geq \min\{\mu_P(x \cdot ((z \cdot y) \cdot y) \cdot z), \mu_P(x)\} \quad ((3.1.7))$$

$$\geq \min\{\mu_P(x \cdot (y \cdot z)), \mu_P(x)\} \quad ((3.2.11) \text{ for } \mu_P)$$

and

$$\nu_P(((z \cdot y) \cdot y) \cdot z) \leq \max\{\nu_P(x \cdot ((z \cdot y) \cdot y) \cdot z), \nu_P(x)\} \quad ((3.1.8))$$

$$\leq \max\{\nu_P(x \cdot (y \cdot z)), \nu_P(x)\}. \quad ((3.2.11) \text{ for } \nu_P)$$

Therefore, P is a Pythagorean fuzzy shift BCC-filter of X . \square

Theorem 3.2.21 *If P is a Pythagorean fuzzy set in X satisfying the following*

condition:

$$(\forall a, x, y, z \in X) \left(\begin{array}{l} (a \leq x \cdot (y \cdot z)) \\ \Rightarrow \mu_P(x \cdot z) \geq \min\{\mu_P(a), \mu_P(x \cdot y)\}, \\ (a \leq x \cdot (y \cdot z)) \\ \Rightarrow \nu_P(x \cdot z) \leq \max\{\nu_P(a), \nu_P(x \cdot y)\} \end{array} \right), \quad (3.2.12)$$

then P is a Pythagorean fuzzy implicative BCC-filter of X .

Proof. Let $P = (\mu_P, \nu_P)$ be a Pythagorean fuzzy set in X satisfying the condition (3.2.12). Let $x \in X$. By (BCC-3), we have $x \cdot (0 \cdot (x \cdot 0)) = 0$, that is, $x \leq 0 \cdot (x \cdot 0)$. It follows from (3.2.12) that

$$\begin{aligned} \mu_P(0) &= \mu_P(0 \cdot 0) \\ &\geq \min\{\mu_P(x), \mu_P(0 \cdot x)\} \\ &= \min\{\mu_P(x), \mu_P(x)\} && ((\text{BCC-2})) \\ &= \mu_P(x), \\ \nu_P(0) &= \nu_P(0 \cdot 0) \\ &\leq \max\{\nu_P(x), \nu_P(0 \cdot x)\} \\ &= \max\{\nu_P(x), \nu_P(x)\} && ((\text{BCC-2})) \\ &= \nu_P(x). \end{aligned}$$

Next, let $x, y, z \in X$. By (2.0.1), we have $(x \cdot (y \cdot z)) \cdot (x \cdot (y \cdot z)) = 0$, that is, $x \cdot (y \cdot z) \leq x \cdot (y \cdot z)$. It follows from (3.2.12) that

$$\begin{aligned} \mu_P(x \cdot z) &\geq \min\{\mu_P(x \cdot (y \cdot z)), \mu_P(x \cdot y)\}, \\ \nu_P(x \cdot z) &\leq \max\{\nu_P(x \cdot (y \cdot z)), \nu_P(x \cdot y)\}. \end{aligned}$$

Therefore, P is a Pythagorean fuzzy implicative BCC-filter of X . \square

Theorem 3.2.22 *If P is a Pythagorean fuzzy set in X satisfying the following condition:*

$$(\forall a, x, y, z \in X) \left(\begin{array}{l} (a \leq x \cdot ((y \cdot z) \cdot y)) \\ \Rightarrow \mu_P(y) \geq \min\{\mu_P(a), \mu_P(x)\}, \\ (a \leq x \cdot ((y \cdot z) \cdot y)) \\ \Rightarrow \nu_P(y) \leq \max\{\nu_P(a), \nu_P(x)\} \end{array} \right), \quad (3.2.13)$$

then P is a Pythagorean fuzzy comparative BCC-filter of X .

Proof. Let $P = (\mu_P, \nu_P)$ be a Pythagorean fuzzy set in X satisfying the condition (3.2.13). Let $x \in X$. By (BCC-3), we have $x \cdot (x \cdot ((0 \cdot x) \cdot 0)) = 0$, that is, $x \leq x \cdot ((0 \cdot x) \cdot 0)$. It follows from (3.2.13) that

$$\begin{aligned} \mu_P(0) &\geq \min\{\mu_P(x), \mu_P(x)\} = \mu_P(x), \\ \nu_P(0) &\leq \max\{\nu_P(x), \nu_P(x)\} = \nu_P(x). \end{aligned}$$

Next, let $x, y, z \in X$. By (2.0.1), we have $(x \cdot ((y \cdot z) \cdot y)) \cdot (x \cdot ((y \cdot z) \cdot y)) = 0$, that is, $x \cdot ((y \cdot z) \cdot y) \leq x \cdot ((y \cdot z) \cdot y)$. It follows from (3.2.13) that

$$\begin{aligned} \mu_P(y) &\geq \min\{\mu_P(x \cdot ((y \cdot z) \cdot y)), \mu_P(x)\}, \\ \nu_P(y) &\leq \max\{\nu_P(x \cdot ((y \cdot z) \cdot y)), \nu_P(x)\}. \end{aligned}$$

Therefore, P is a Pythagorean fuzzy comparative BCC-filter of X . \square

Theorem 3.2.23 *If P is a Pythagorean fuzzy set in X satisfying the conditions*

(3.1.7) and (3.1.8) and the following condition:

$$(\forall x, y, z \in X) \left(\begin{array}{l} \mu_P(x \cdot ((y \cdot z) \cdot y)) \geq \mu_P((x \cdot ((y \cdot z) \cdot y)) \cdot y) \\ \Rightarrow \mu_P((x \cdot ((y \cdot z) \cdot y)) \cdot y) \geq \mu_P(x), \\ \nu_P(x \cdot ((y \cdot z) \cdot y)) \leq \nu_P((x \cdot ((y \cdot z) \cdot y)) \cdot y) \\ \Rightarrow \nu_P(((x \cdot ((y \cdot z) \cdot y)) \cdot y)) \leq \nu_P(x) \end{array} \right), \quad (3.2.14)$$

then P is a Pythagorean fuzzy comparative BCC-filter of X .

Proof. Let $P = (\mu_P, \nu_P)$ be a Pythagorean fuzzy set in X satisfying the conditions (3.1.7), (3.1.8), and (3.2.14). Let $x \in X$. By (BCC-2) and (BCC-3), we have

$$\begin{aligned} \mu_P(x \cdot ((0 \cdot x) \cdot 0)) &= \mu_P(0) \geq \mu_P(0) = \mu_P((x \cdot ((0 \cdot x) \cdot 0)) \cdot 0), \\ \nu_P(x \cdot ((0 \cdot x) \cdot 0)) &= \nu_P(0) \leq \nu_P(0) = \nu_P((x \cdot ((0 \cdot x) \cdot 0)) \cdot 0). \end{aligned}$$

It follows from (3.2.14) that

$$\begin{aligned} \mu_P(0) &= \mu_P((x \cdot ((0 \cdot x) \cdot 0)) \cdot 0) \geq \mu_P(x), \\ \nu_P(0) &= \nu_P((x \cdot ((0 \cdot x) \cdot 0)) \cdot 0) \leq \nu_P(x). \end{aligned}$$

Thus P satisfies the conditions (3.1.5) and (3.1.6). In case of $\mu_P(x \cdot ((y \cdot z) \cdot y)) < \mu_P((x \cdot ((y \cdot z) \cdot y)) \cdot y)$ and $\nu_P(x \cdot ((y \cdot z) \cdot y)) > \nu_P((x \cdot ((y \cdot z) \cdot y)) \cdot y)$ are easy to verify. Next, let $x, y, z \in X$. Then

$$\mu_P(y) \geq \min\{\mu_P((x \cdot ((y \cdot z) \cdot y)) \cdot y), \mu_P(x \cdot ((y \cdot z) \cdot y))\} \quad ((3.1.7))$$

$$= \min\{\mu_P(x \cdot ((y \cdot z) \cdot y)), \mu_P(x)\}, \quad ((3.2.14) \text{ for } \mu_P)$$

$$\nu_P(y) \leq \max\{\nu_P((x \cdot ((y \cdot z) \cdot y)) \cdot y), \nu_P(x \cdot ((y \cdot z) \cdot y))\} \quad ((3.1.8))$$

$$= \max\{\nu_P(x \cdot ((y \cdot z) \cdot y)), \nu_P(x)\}. \quad ((3.2.14) \text{ for } \nu_P)$$

Therefore, P is a Pythagorean fuzzy comparative BCC-filter of X . \square

Theorem 3.2.24 *If P is a Pythagorean fuzzy set in X satisfying the following condition:*

$$(\forall a, x, y, z \in X) \left(\begin{array}{l} (a \leq x \cdot (y \cdot z)) \\ \Rightarrow \mu_P(((z \cdot y) \cdot y) \cdot z) \geq \min\{\mu_P(a), \mu_P(x)\}, \\ (a \leq x \cdot (y \cdot z)) \\ \Rightarrow \nu_P(((z \cdot y) \cdot y) \cdot z) \leq \max\{\nu_P(a), \nu_P(x)\} \end{array} \right), \quad (3.2.15)$$

then P is a Pythagorean fuzzy shift BCC-filter of X .

Proof. Let $P = (\mu_P, \nu_P)$ be a Pythagorean fuzzy set in X satisfying the condition (3.2.15). Let $x \in X$. By (BCC-3), we have $x \cdot (x \cdot (x \cdot 0)) = 0$, that is, $x \leq x \cdot (x \cdot 0)$. It follows from (3.2.15) that

$$\mu_P(0) = \mu_P(((0 \cdot x) \cdot x) \cdot 0) \geq \min\{\mu_P(x), \mu_P(x)\} = \mu_P(x), \quad ((\text{BCC-2}))$$

$$\nu_P(0) = \nu_P(((0 \cdot x) \cdot x) \cdot 0) \leq \max\{\nu_P(x), \nu_P(x)\} = \nu_P(x). \quad ((\text{BCC-2}))$$

Next, let $x, y, z \in X$. By (2.0.1), we have $(x \cdot (y \cdot z)) \cdot (x \cdot (y \cdot z)) = 0$, that is, $x \cdot (y \cdot z) \leq x \cdot (y \cdot z)$. It follows from (3.2.15) that

$$\mu_P(((z \cdot y) \cdot y) \cdot z) \geq \min\{\mu_P(x \cdot (y \cdot z)), \mu_P(x)\},$$

$$\nu_P(((z \cdot y) \cdot y) \cdot z) \leq \max\{\nu_P(x \cdot (y \cdot z)), \nu_P(x)\}.$$

Therefore, P is a Pythagorean fuzzy shift BCC-filter of X . □

Theorem 3.2.25 *If P is a Pythagorean fuzzy set in X satisfying the conditions*

(3.1.7) and (3.1.8) and the following condition:

$$(\forall x, y, z \in X) \left(\begin{array}{l} \mu_P(x \cdot (y \cdot z)) \geq \mu_P((x \cdot (y \cdot z)) \cdot (((z \cdot y) \cdot y) \cdot z)) \\ \Rightarrow \mu_P((x \cdot (y \cdot z)) \cdot (((z \cdot y) \cdot y) \cdot z)) \geq \mu_P(x), \\ \nu_P(x \cdot (y \cdot z)) \leq \nu_P((x \cdot (y \cdot z)) \cdot (((z \cdot y) \cdot y) \cdot z)) \\ \Rightarrow \nu_P((x \cdot (y \cdot z)) \cdot (((z \cdot y) \cdot y) \cdot z)) \leq \nu_P(x) \end{array} \right), \quad (3.2.16)$$

then P is a Pythagorean fuzzy shift BCC-filter of X .

Proof. Let $P = (\mu_P, \nu_P)$ be a Pythagorean fuzzy set in X satisfying the conditions (3.1.7), (3.1.8), and (3.2.16). Let $x \in X$. By (BCC-2) and (BCC-3), we have

$$\begin{aligned} \mu_P(x \cdot (x \cdot 0)) &= \mu_P(0) \geq \mu_P(0) = \mu_P((x \cdot (x \cdot 0)) \cdot (((0 \cdot x) \cdot x) \cdot 0)), \\ \nu_P(x \cdot (x \cdot 0)) &= \nu_P(0) \leq \nu_P(0) = \nu_P((x \cdot (x \cdot 0)) \cdot (((0 \cdot x) \cdot x) \cdot 0)). \end{aligned}$$

It follows from (3.2.16) that

$$\begin{aligned} \mu_P(0) &= \mu_P((x \cdot (x \cdot 0)) \cdot (((0 \cdot x) \cdot x) \cdot 0)) \geq \mu_P(x), \\ \nu_P(0) &= \nu_P((x \cdot (x \cdot 0)) \cdot (((0 \cdot x) \cdot x) \cdot 0)) \leq \nu_P(x). \end{aligned}$$

Thus P satisfies the conditions (3.1.5) and (3.1.6). In case of $\mu_P(x \cdot (y \cdot z)) < \mu_P((x \cdot (y \cdot z)) \cdot (((z \cdot y) \cdot y) \cdot z))$ and $\nu_P(x \cdot (y \cdot z)) > \nu_P((x \cdot (y \cdot z)) \cdot (((z \cdot y) \cdot y) \cdot z))$ are easy to verify. Next, let $x, y, z \in X$. Then

$$\begin{aligned} &\mu_P(((z \cdot y) \cdot y) \cdot z) \\ &\geq \min\{\mu_P((x \cdot (y \cdot z)) \cdot (((z \cdot y) \cdot y) \cdot z)), \mu_P(x \cdot (y \cdot z))\} \quad ((3.1.7)) \\ &= \min\{\mu_P(x \cdot (y \cdot z)), \mu_P(x)\}, \quad ((3.2.16) \text{ for } \mu_P) \\ &\nu_P(((z \cdot y) \cdot y) \cdot z) \\ &\leq \max\{\nu_P((x \cdot (y \cdot z)) \cdot (((z \cdot y) \cdot y) \cdot z)), \nu_P(x \cdot (y \cdot z))\} \quad ((3.1.7)) \end{aligned}$$

$$= \max\{\nu_P(x \cdot (y \cdot z)), \nu_P(x)\}. \quad ((3.2.16) \text{ for } \mu_P)$$

Therefore, P is a Pythagorean fuzzy shift BCC-filter of X . \square

Proposition 3.2.26 *A Pythagorean fuzzy set $P = (\mu_P, \nu_P)$ in X satisfies the following conditions:*

$$(\forall a, x, y, z \in X) \left(\begin{array}{l} a \leq x \cdot (y \cdot z) \\ \Rightarrow \mu_P(x \cdot z) \geq \min\{\mu_P(a), \mu_P(y)\}, \\ a \leq x \cdot (y \cdot z) \\ \Rightarrow \nu_P(x \cdot z) \leq \max\{\nu_P(a), \nu_P(y)\} \end{array} \right), \quad (3.2.17)$$

if and only if it is a Pythagorean fuzzy BCC-ideal of X .

Proof. Let $x \in X$. By (BCC-3), we have $x \leq x \cdot (x \cdot 0)$. Then

$$\mu_P(0) = \mu_P(x \cdot 0) \geq \min\{\mu_P(x), \mu_P(x)\} = \mu_P(x) \quad ((\text{BCC-3}) \text{ and } (3.2.17))$$

and

$$\nu_P(0) = \nu_P(x \cdot 0) \leq \max\{\nu_P(x), \nu_P(x)\} = \nu_P(x). \quad ((\text{BCC-3}) \text{ and } (3.2.17))$$

Let $x, y, z \in X$. By (2.0.1), we have $x \cdot (y \cdot z) \leq x \cdot (y \cdot z)$. Then

$$\mu_P(x \cdot z) \geq \min\{\mu_P(x \cdot (y \cdot z)), \mu_P(y)\} \quad ((3.2.17))$$

and

$$\nu_P(x \cdot z) \leq \max\{\nu_P(x \cdot (y \cdot z)), \nu_P(y)\}. \quad ((3.2.17))$$

Hence, P is a Pythagorean fuzzy BCC-ideal of X .

Conversely, let $a, x, y, z \in X$ be such that $a \leq x \cdot (y \cdot z)$. By (3.2.1) and (3.2.1), we have $\mu_P(a) \leq \mu_P(x \cdot (y \cdot z))$ and $\nu_P(a) \geq \nu_P(x \cdot (y \cdot z))$. Thus

$$\mu_P(x \cdot z) \geq \min\{\mu_P(x \cdot (y \cdot z)), \mu_P(y)\} \geq \min\{\mu_P(a), \mu_P(y)\} \quad ((3.1.15))$$

and

$$\nu_P(x \cdot z) \leq \max\{\nu_P(x \cdot (y \cdot z)), \nu_P(y)\} \leq \max\{\nu_P(a), \nu_P(y)\}. \quad ((3.1.16))$$

□

Proposition 3.2.27 *If $P = (\mu_P, \nu_P)$ is a Pythagorean fuzzy BCC-ideal of X , then*

$$(\forall a, x, y, z \in X) \left(\begin{array}{l} a \leq x \cdot (y \cdot z) \\ \Rightarrow \mu_P(a \cdot z) \geq \min\{\mu_P(x), \mu_P(y)\}, \\ a \leq x \cdot (y \cdot z) \\ \Rightarrow \nu_P(a \cdot z) \leq \max\{\nu_P(x), \nu_P(y)\} \end{array} \right), \quad (3.2.18)$$

Proof. Let $a, x, y, z \in X$ such that $a \leq x \cdot (y \cdot z)$. Then $a \cdot (x \cdot (y \cdot z)) = 0$, so

$$\begin{aligned} \mu_P(a \cdot (y \cdot z)) &\geq \min\{\mu_P(a \cdot (x \cdot (y \cdot z))), \mu_P(x)\} \\ &= \min\{\mu_P(0), \mu_P(x)\} \\ &= \mu_P(x) \end{aligned} \quad ((3.1.15))$$

and

$$\begin{aligned} \nu_P(a \cdot (y \cdot z)) &\leq \max\{\nu_P(a \cdot (x \cdot (y \cdot z))), \nu_P(x)\} \\ &= \max\{\nu_P(0), \nu_P(x)\} \\ &= \nu_P(x). \end{aligned} \quad ((3.1.16))$$

Thus

$$\mu_P(a \cdot z) \geq \min\{\mu_P(a \cdot (y \cdot z)), \mu_P(y)\} \geq \min\{\mu_P(x), \mu_P(y)\} \quad ((3.1.15))$$

and

$$\nu_P(a \cdot z) \leq \max\{\nu_P(a \cdot (y \cdot z)), \nu_P(y)\} \leq \max\{\nu_P(x), \nu_P(y)\}. \quad ((3.1.16))$$

□

Corollary 3.2.28 *If $P = (\mu_P, \nu_P)$ is a Pythagorean fuzzy set in X satisfying the condition (3.2.17), then it satisfies the condition (3.2.18).*

Proof. It is straightforward by Propositions 3.2.26 and 3.2.27. □

Theorem 3.2.29 *If $P = (\mu_P, \nu_P)$ is a Pythagorean fuzzy set in X satisfying the conditions (2.0.14) and (3.2.18), then it satisfies the condition (3.2.17).*

Proof. Let $a, x, y, z \in X$ be such that $a \leq x \cdot (y \cdot z)$. By (2.0.14), we have $0 = a \cdot (x \cdot (y \cdot z)) = x \cdot (a \cdot (y \cdot z))$, that is, $x \leq a \cdot (y \cdot z)$. It follows from (3.2.18) that $\mu_P(x \cdot z) \geq \min\{\mu_P(a), \mu_P(y)\}$ and $\nu_P(x \cdot z) \leq \max\{\nu_P(a), \nu_P(y)\}$. □

Theorem 3.2.30 *If $P = (\mu_P, \nu_P)$ is a Pythagorean fuzzy set in X satisfying the condition (3.2.18), then it satisfies the condition (3.2.6).*

Proof. Let $x, y, z \in X$ be such that $z \leq x \cdot y$. By (2.0.1) and (2.0.3), we have $0 = z \cdot z \leq z \cdot (x \cdot y)$. By (BCC-2) and (3.2.18), we have $\mu_P(y) = \mu_P(0 \cdot y) \geq \min\{\mu_P(z), \mu_P(x)\}$ and $\nu_P(y) = \nu_P(0 \cdot y) \leq \max\{\nu_P(z), \nu_P(x)\}$. □

Corollary 3.2.31 *If $P = (\mu_P, \nu_P)$ is a Pythagorean fuzzy set in X satisfying the condition (3.2.17), then it satisfies the condition (3.2.6).*

Proof. It is straightforward by Corollary 3.2.28 and Theorem 3.2.30. □

In general, the converse of Theorem 3.2.30 may be not true by the following example.

Example 3.2.32 From Example 3.2.8, we define a Pythagorean fuzzy set $P = (\mu_P, \nu_P)$ with the membership function μ_P and the non-membership function ν_P as follows:

X	0	1	2	3
μ_P	0.7	0.3	0.2	0.2
ν_P	0.3	0.7	0.75	0.75

Then P satisfies the condition (3.2.6) but it does not satisfy the condition (3.2.18). Indeed, $3 \leq 1 \cdot (0 \cdot 2)$ but $\mu_P(3 \cdot 2) = \mu_P(2) = 0.2 \not\geq 0.3 = \min\{0.3, 0.7\} = \min\{\mu_P(1), \mu_P(0)\}$ and $\nu_P(3 \cdot 2) = \nu_P(2) = 0.75 \not\leq 0.7 = \max\{0.7, 0.3\} = \max\{\nu_P(1), \nu_P(0)\}$.

The following example shows that Pythagorean fuzzy set in a BCC-algebra which satisfies the condition (3.2.17) is not constant.

Example 3.2.33 From Example 3.1.22, we define a Pythagorean fuzzy set $P = (\mu_P, \nu_P)$ with the membership function μ_P and the non-membership function ν_P as follows:

X	0	1	2	3
μ_P	1	0.8	0.5	0.5
ν_P	0	0.3	0.6	0.6

Then P satisfies the condition (3.2.17) but it is not constant.

Theorem 3.2.34 *If $P = (\mu_P, \nu_P)$ is a Pythagorean fuzzy BCC-filter of X satisfying the condition (2.0.14), then it is a Pythagorean fuzzy BCC-ideal of X .*

Proof. Let P be a Pythagorean fuzzy BCC-filter of X . Then for all $x, y, z \in X$,

$$\mu_P(x \cdot z) \geq \min\{\mu_P(y \cdot (x \cdot z)), \mu_P(y)\}$$

$$= \min\{\mu_P(x \cdot (y \cdot z)), \mu_P(y)\} \quad ((3.1.7) \text{ and } (2.0.14))$$

and

$$\begin{aligned} \nu_P(x \cdot z) &\leq \max\{\nu_P(y \cdot (x \cdot z)), \nu_P(y)\} \\ &= \max\{\nu_P(x \cdot (y \cdot z)), \nu_P(y)\}. \end{aligned} \quad ((3.1.8) \text{ and } (2.0.14))$$

Hence, P is a Pythagorean fuzzy BCC-ideal of X . \square

Proposition 3.2.35 *A Pythagorean fuzzy set $P = (\mu_P, \nu_P)$ in X satisfies the following conditions:*

$$(\forall a, x, y, z \in X) \left(\begin{array}{l} a \leq (z \cdot y) \cdot (z \cdot x) \\ \Rightarrow \mu_P(x) \geq \min\{\mu_P(a), \mu_P(y)\}, \\ a \leq (z \cdot y) \cdot (z \cdot x) \\ \Rightarrow \nu_P(x) \leq \max\{\nu_P(a), \nu_P(y)\} \end{array} \right), \quad (3.2.19)$$

if and only if it is a Pythagorean fuzzy strong BCC-ideal of X .

Proof. Let $x \in X$. By (BCC-3), we have $x \leq 0 = x \cdot 0 = (0 \cdot x) \cdot (0 \cdot 0)$. By (3.2.19), we have $\mu_P(0) \geq \min\{\mu_P(x), \mu_P(x)\} = \mu_P(x)$ and $\nu_P(0) \leq \max\{\nu_P(x), \nu_P(x)\} = \nu_P(x)$. Next, let $x, y, z \in X$. By (2.0.1), we have $(z \cdot y) \cdot (z \cdot x) \leq (z \cdot y) \cdot (z \cdot x)$. By (3.2.19), we have $\mu_P(x) \geq \min\{\mu_P((z \cdot y) \cdot (z \cdot x)), \mu_P(y)\}$ and $\nu_P(x) \leq \max\{\nu_P((z \cdot y) \cdot (z \cdot x)), \nu_P(y)\}$. Hence, P is a Pythagorean fuzzy strong BCC-ideal of X .

The converse is obvious because P is constant by Theorem 3.1.2. \square

Theorem 3.2.36 *If $P = (\mu_P, \nu_P)$ is a Pythagorean fuzzy set in X satisfying the following conditions:*

$$(\forall x, y, z \in X) \left(\begin{array}{l} z \leq x \cdot y \Rightarrow \mu_P(z) \geq \min\{\mu_P(x), \mu_P(y)\}, \\ z \leq x \cdot y \Rightarrow \nu_P(z) \leq \max\{\nu_P(x), \nu_P(y)\} \end{array} \right), \quad (3.2.20)$$

then it satisfies the condition (3.2.3).

Proof. Let $x, y, z \in X$ be such that $z \leq x$. By (2.0.4), we have $x \cdot y \leq z \cdot y$. By (3.2.20), we have $\mu_P(x \cdot y) \geq \min\{\mu_P(z), \mu_P(y)\}$ and $\nu_P(x \cdot y) \leq \max\{\nu_P(z), \nu_P(y)\}$. \square

Proposition 3.2.37 *A Pythagorean fuzzy set $P = (\mu_P, \nu_P)$ in X satisfies the condition (3.2.20) if and only if it is a Pythagorean fuzzy strong BCC-ideal of X .*

Proof. Let $x \in X$. By (BCC-3), we have $x \leq 0 = 0 \cdot 0$. By (3.2.20), we have $\mu_P(x) \geq \min\{\mu_P(0), \mu_P(0)\} = \mu_P(0)$ and $\nu_P(x) \leq \max\{\nu_P(0), \nu_P(0)\} = \nu_P(0)$. By Theorem 3.2.36, we have P satisfies (3.2.3). Thus P a Pythagorean fuzzy BCC-subalgebra of X by Proposition 3.2.4. It follows from Proposition 3.2.1 that $\mu_P(0) \geq \mu_P(x)$ and $\nu_P(0) \leq \nu_P(x)$, so $\mu_P(x) = \mu_P(0)$ and $\nu_P(x) = \nu_P(0)$ for all $x \in X$, that is, P is constant. By Theorem 3.1.2, we have P is a Pythagorean fuzzy strong BCC-ideal of X .

The converse is obvious because P is constant by Theorem 3.1.2. \square

Theorem 3.2.38 *If $P = (\mu_P, \nu_P)$ is a Pythagorean fuzzy set in X satisfying the following conditions:*

$$(\forall x, y, z \in X) \begin{pmatrix} z \leq x \cdot y \Rightarrow \mu_P(z) \geq \mu_P(y), \\ z \leq x \cdot y \Rightarrow \nu_P(z) \leq \nu_P(y) \end{pmatrix}, \quad (3.2.21)$$

then it satisfies the condition (3.2.3).

Proof. Let $x, y, z \in X$ be such that $z \leq x$. By (2.0.4), we have $x \cdot y \leq z \cdot y$. It follows from (3.2.21) that $\mu_P(x \cdot y) \geq \mu_P(y) \geq \min\{\mu_P(z), \mu_P(y)\}$ and $\nu_P(x \cdot y) \leq \nu_P(y) \leq \max\{\nu_P(z), \nu_P(y)\}$. \square

Proposition 3.2.39 *A Pythagorean fuzzy set $P = (\mu_P, \nu_P)$ in X satisfies the condition (3.2.21) if and only if it is a Pythagorean fuzzy strong BCC-ideal of X .*

Proof. Let $x \in X$. By (BCC-3), we have $x \leq 0 = 0 \cdot 0$. By (3.2.21), we have $\mu_P(x) \geq \mu_P(0)$ and $\nu_P(x) \leq \nu_P(0)$. By Theorem 3.2.36, we have P satisfies (3.2.3). Thus P is a Pythagorean fuzzy BCC-subalgebra of X by Proposition 3.2.4. It follows from Proposition 3.2.1 that $\mu_P(0) \geq \mu_P(x)$ and $\nu_P(0) \leq \nu_P(x)$, so $\mu_P(x) = \mu_P(0)$ and $\nu_P(x) = \nu_P(0)$ for all $x \in X$, that is, P is constant. By Theorem 3.1.2, we have P is a Pythagorean fuzzy strong BCC-ideal of X .

The converse is obvious because P is constant by Theorem 3.1.2. \square

We get the diagram of sufficient conditions of Pythagorean fuzzy sets in BCC-algebras, which is shown with Figure 2.

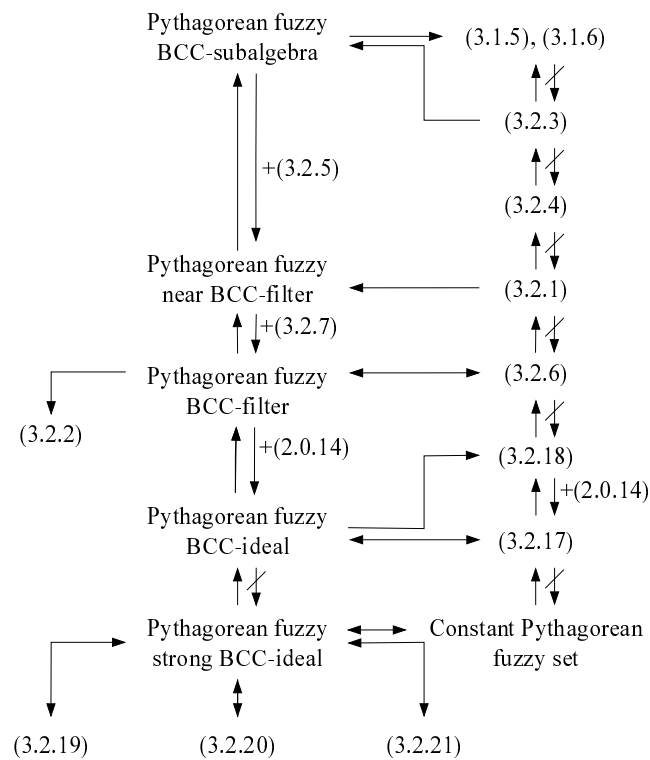

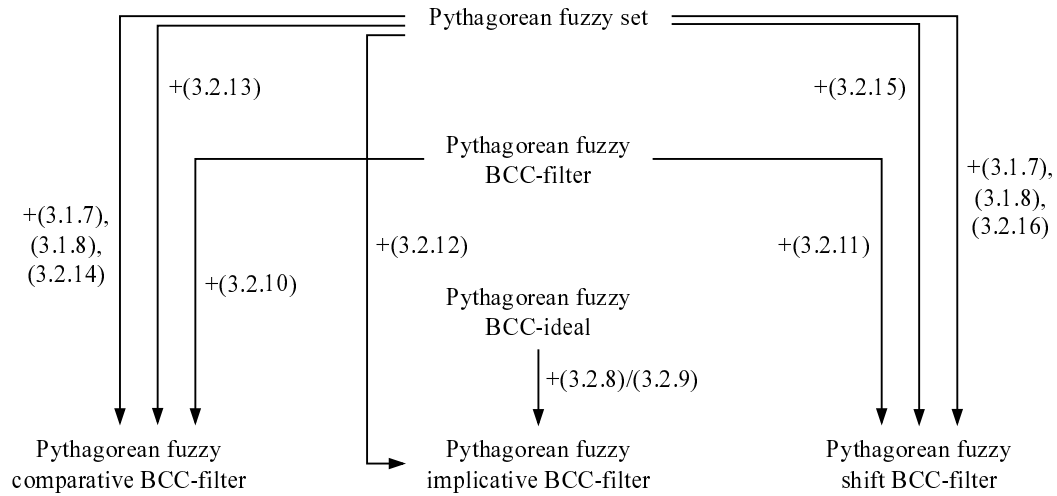

Figure 2: Properties of Pythagorean fuzzy sets in BCC-algebras

3.3 Upper and lower approximations of Pythagorean fuzzy sets

Definition 3.3.1 Let ρ be an equivalence relation on a nonempty set X and $P = (\mu_P, \nu_P)$ a Pythagorean fuzzy set in X . The *upper approximation* is defined by

$$\rho^+(P) = \{(x, \bar{\mu}_P(x), \bar{\nu}_P(x)) \mid x \in X\},$$

where $\bar{\mu}_P(x) = \sup_{a \in (x)_\rho} \{\mu_P(a)\}$ and $\bar{\nu}_P(x) = \inf_{a \in (x)_\rho} \{\nu_P(a)\}$. The *lower approximation* is defined by

$$\rho^-(P) = \{(x, \underline{\mu}_P(x), \underline{\nu}_P(x)) \mid x \in X\},$$

where $\underline{\mu}_P(x) = \inf_{a \in (x)_\rho} \{\mu_P(a)\}$ and $\underline{\nu}_P(x) = \sup_{a \in (x)_\rho} \{\nu_P(a)\}$.

Theorem 3.3.2 Let ρ be an equivalence relation on a nonempty set X and $P = (\mu_P, \nu_P)$ a Pythagorean fuzzy set in X . Then the following statements hold:

- (1) $\rho^+(P)$ is a Pythagorean fuzzy set in X , and
- (2) $\rho^-(P)$ is a Pythagorean fuzzy set in X .

Proof. Let $x \in X$.

(1) We consider

$$\begin{aligned}
0 &\leq \bar{\mu}_P(x)^2 + \bar{\nu}_P(x)^2 \\
&= \sup_{a \in (x)_\rho} \{\mu_P(a)\}^2 + \inf_{a \in (x)_\rho} \{\nu_P(a)\}^2 \\
&= \sup_{a \in (x)_\rho} \{\mu_P(a)^2\} + \inf_{a \in (x)_\rho} \{\nu_P(a)^2\} && \text{(Proposition 2.0.10 (6))} \\
&\leq \sup_{a \in (x)_\rho} \{\mu_P(a)^2\} + \inf_{a \in (x)_\rho} \{1 - \mu_P(a)^2\} \\
&= \sup_{a \in (x)_\rho} \{\mu_P(a)^2\} + 1 - \sup_{a \in (x)_\rho} \{\mu_P(a)^2\} && \text{(Proposition 2.0.10 (7))} \\
&= 1.
\end{aligned}$$

This implies that $0 \leq \bar{\mu}_P(x)^2 + \bar{\nu}_P(x)^2 \leq 1$. Therefore, $\rho^+(P)$ is a Pythagorean fuzzy set in X .

(2) The proof is similar to the proof of (1). □

Then we call P that a *rough Pythagorean fuzzy set* in a set X . Thus we can denote the upper approximation and the lower approximation by $\rho^+(P) = (\bar{\mu}_P, \bar{\nu}_P)$ and $\rho^-(P) = (\underline{\mu}_P, \underline{\nu}_P)$, respectively.

Proposition 3.3.3 *Let $P = (\mu_P, \nu_P)$ and $Q = (\mu_Q, \nu_Q)$ be Pythagorean fuzzy sets in X . If ρ is an equivalence relation on X , then the following statements hold:*

- (1) $\rho^-(P) \subseteq P \subseteq \rho^+(P)$,
- (2) $P \subseteq Q \Rightarrow \rho^+(P) \subseteq \rho^+(Q), \rho^-(P) \subseteq \rho^-(Q)$,
- (3) $\rho^+(P \cup Q) = \rho^+(P) \cup \rho^+(Q)$,
- (4) $\rho^+(P \cap Q) \subseteq \rho^+(P) \cap \rho^+(Q)$,
- (5) $\rho^-(P \cup Q) \supseteq \rho^-(P) \cup \rho^-(Q)$, and

$$(6) \quad \rho^-(P \cap Q) = \rho^-(P) \cap \rho^-(Q).$$

Proof. Let ρ be an equivalence relation on X .

(1) Then for all $x \in X$,

$$\begin{aligned} \underline{\mu}_P(x) &= \inf_{a \in (x)_\rho} \{\mu_P(a)\} \\ &\leq \mu_P(x) \\ &\leq \sup_{a \in (x)_\rho} \{\mu_P(a)\} \\ &= \bar{\mu}_P(x) \end{aligned}$$

and

$$\begin{aligned} \underline{\nu}_P(x) &= \sup_{a \in (x)_\rho} \{\nu_P(a)\} \\ &\geq \nu_P(x) \\ &\geq \inf_{a \in (x)_\rho} \{\nu_P(a)\} \\ &= \bar{\nu}_P(x). \end{aligned}$$

By Definition 2.0.17 (1), we have $\rho^-(P) \subseteq P \subseteq \rho^+(P)$.

(2) If $P \subseteq Q$, then $\mu_P(x) \leq \mu_Q(x)$ and $\nu_P(x) \geq \nu_Q(x)$ for all $x \in X$. We consider

$$\begin{aligned} \bar{\mu}_P(x) &= \sup_{a \in (x)_\rho} \{\mu_P(a)\} \\ &\leq \sup_{a \in (x)_\rho} \{\mu_Q(a)\} && \text{(Proposition 2.0.10 (6))} \\ &= \bar{\mu}_Q(x), \end{aligned}$$

$$\begin{aligned}
\bar{\nu}_P(x) &= \inf_{a \in (x)_\rho} \{\mu_P(a)\} \\
&\geq \inf_{a \in (x)_\rho} \{\mu_Q(a)\} && \text{(Proposition 2.0.10 (8))} \\
&= \bar{\nu}_Q(x),
\end{aligned}$$

$$\begin{aligned}
\underline{\mu}_P(x) &= \inf_{a \in (x)_\rho} \{\mu_P(a)\} \\
&\leq \inf_{a \in (x)_\rho} \{\mu_Q(a)\} && \text{(Proposition 2.0.10 (8))} \\
&= \underline{\mu}_Q(x),
\end{aligned}$$

and

$$\begin{aligned}
\underline{\nu}_P(x) &= \sup_{a \in (x)_\rho} \{\mu_P(a)\} \\
&\geq \sup_{a \in (x)_\rho} \{\mu_Q(a)\} && \text{(Proposition 2.0.10 (6))} \\
&= \underline{\nu}_Q(x).
\end{aligned}$$

By Definition 2.0.17 (1), we have $\rho^+(P) \subseteq \rho^+(Q)$ and $\rho^-(P) \subseteq \rho^-(Q)$.

(3) By Definition 2.0.17 (3), we have $P \cup Q = (\mu_{P \cup Q}, \nu_{P \cup Q})$. Then we know that

$$\rho^+(P \cup Q) = (\bar{\mu}_{P \cup Q}, \bar{\nu}_{P \cup Q})$$

and

$$\rho^+(P) \cup \rho^+(Q) = (\bar{\mu}_P \cup \bar{\mu}_Q, \bar{\nu}_P \cap \bar{\nu}_Q).$$

Thus for all $x \in X$,

$$\bar{\mu}_{P \cup Q}(x) = \sup_{a \in (x)_\rho} \{\mu_{P \cup Q}(a)\}$$

$$\begin{aligned}
&= \sup_{a \in (x)_\rho} \{(\mu_P \cup \mu_Q)(a)\} \\
&= \sup_{a \in (x)_\rho} \{\max\{\mu_P(a), \mu_Q(a)\}\} \\
&= \max\left\{ \sup_{a \in (x)_\rho} \{\mu_P(a)\}, \sup_{a \in (x)_\rho} \{\mu_Q(a)\} \right\} \quad (\text{Proposition 2.0.10 (2)}) \\
&= \max\{\bar{\mu}_P(x), \bar{\mu}_Q(x)\} \\
&= (\bar{\mu}_P \cup \bar{\mu}_Q)(x)
\end{aligned}$$

and

$$\begin{aligned}
\bar{\nu}_{P \cup Q}(x) &= \inf_{a \in (x)_\rho} \{\nu_{P \cup Q}(a)\} \\
&= \inf_{a \in (x)_\rho} \{(\nu_P \cap \nu_Q)(a)\} \\
&= \inf_{a \in (x)_\rho} \{\min\{\nu_P(a), \nu_Q(a)\}\} \\
&= \min\left\{ \inf_{a \in (x)_\rho} \{\nu_P(a)\}, \inf_{a \in (x)_\rho} \{\nu_Q(a)\} \right\} \quad (\text{Proposition 2.0.10 (1)}) \\
&= \min\{\bar{\nu}_P(x), \bar{\nu}_Q(x)\} \\
&= (\bar{\nu}_P \cap \bar{\nu}_Q)(x).
\end{aligned}$$

Hence, $\rho^+(P \cup Q) = \rho^+(P) \cup \rho^+(Q)$.

(4) By Definition 2.0.17 (4), we have $P \cap Q = (\mu_{P \cap Q}, \nu_{P \cap Q})$. Then we know that

$$\rho^+(P \cap Q) = (\bar{\mu}_{P \cap Q}, \bar{\nu}_{P \cap Q})$$

and

$$\rho^+(P) \cap \rho^+(Q) = (\bar{\mu}_P \cap \bar{\mu}_Q, \bar{\nu}_P \cup \bar{\nu}_Q).$$

Thus for all $x \in X$,

$$\bar{\mu}_{P \cap Q}(x) = \sup_{a \in (x)_\rho} \{\mu_{P \cap Q}(a)\}$$

$$\begin{aligned}
&= \sup_{a \in (x)_\rho} \{(\mu_P \cap \mu_Q)(a)\} \\
&= \sup_{a \in (x)_\rho} \{\min\{\mu_P(a), \mu_Q(a)\}\} \\
&\leq \min\left\{ \sup_{a \in (x)_\rho} \{\mu_P(a)\}, \sup_{a \in (x)_\rho} \{\mu_Q(a)\} \right\} \quad (\text{Proposition 2.0.10 (4)}) \\
&= \min\{\bar{\mu}_P(x), \bar{\mu}_Q(x)\} \\
&= (\bar{\mu}_P \cap \bar{\mu}_Q)(x)
\end{aligned}$$

and

$$\begin{aligned}
\bar{\nu}_{P \cap Q}(x) &= \inf_{a \in (x)_\rho} \{\nu_{P \cap Q}(a)\} \\
&= \inf_{a \in (x)_\rho} \{(\nu_P \cup \nu_Q)(a)\} \\
&= \inf_{a \in (x)_\rho} \{\max\{\nu_P(a), \nu_Q(a)\}\} \\
&\geq \max\left\{ \inf_{a \in (x)_\rho} \{\nu_P(a)\}, \inf_{a \in (x)_\rho} \{\nu_Q(a)\} \right\} \quad (\text{Proposition 2.0.10 (3)}) \\
&= \max\{\bar{\nu}_P(x), \bar{\nu}_Q(x)\} \\
&= (\bar{\nu}_P \cup \bar{\nu}_Q)(x).
\end{aligned}$$

Hence, $\rho^+(P \cap Q) \subseteq \rho^+(P) \cap \rho^+(Q)$.

(5) By Definition 2.0.17 (3), we have $P \cup Q = (\mu_{P \cup Q}, \nu_{P \cup Q})$. Then we know that

$$\rho^-(P \cup Q) = (\underline{\mu}_{P \cup Q}, \underline{\nu}_{P \cup Q})$$

and

$$\rho^-(P) \cup \rho^-(Q) = (\underline{\mu}_P \cup \underline{\mu}_Q, \underline{\nu}_P \cap \underline{\nu}_Q).$$

Thus for all $x \in X$,

$$\underline{\mu}_{P \cup Q}(x) = \inf_{a \in (x)_\rho} \{\mu_{P \cup Q}(a)\}$$

$$\begin{aligned}
&= \inf_{a \in (x)_\rho} \{(\mu_P \cup \mu_Q)(a)\} \\
&= \inf_{a \in (x)_\rho} \{\max\{\mu_P(a), \mu_Q(a)\}\} \\
&\geq \max\{\inf_{a \in (x)_\rho} \{\mu_P(a)\}, \inf_{a \in (x)_\rho} \{\mu_Q(a)\}\} \quad (\text{Proposition 2.0.10 (3)}) \\
&= \max\{\underline{\mu}_P(x), \underline{\mu}_Q(x)\} \\
&= (\underline{\mu}_P \cup \underline{\mu}_Q)(x)
\end{aligned}$$

and

$$\begin{aligned}
\underline{\nu}_{P \cup Q}(x) &= \sup_{a \in (x)_\rho} \{\nu_{P \cup Q}(a)\} \\
&= \sup_{a \in (x)_\rho} \{(\nu_P \cap \nu_Q)(a)\} \\
&= \sup_{a \in (x)_\rho} \{\min\{\nu_P(a), \nu_Q(a)\}\} \\
&\leq \min\{\sup_{a \in (x)_\rho} \{\nu_P(a)\}, \sup_{a \in (x)_\rho} \{\nu_Q(a)\}\} \quad (\text{Proposition 2.0.10 (4)}) \\
&= \min\{\underline{\nu}_P(x), \underline{\nu}_Q(x)\} \\
&= (\underline{\nu}_P \cap \underline{\nu}_Q)(x).
\end{aligned}$$

Hence, $\rho^-(P \cup Q) \supseteq \rho^-(P) \cup \rho^-(Q)$.

(6) By Definition 2.0.17 (4), we have $P \cap Q = (\mu_{P \cap Q}, \nu_{P \cap Q})$. Then we know that

$$\rho^-(P \cap Q) = (\underline{\mu}_{P \cap Q}, \underline{\nu}_{P \cap Q})$$

and

$$\rho^-(P) \cap \rho^-(Q) = (\underline{\mu}_P \cap \underline{\mu}_Q, \underline{\nu}_P \cup \underline{\nu}_Q).$$

Thus for all $x \in X$,

$$\underline{\mu}_{P \cap Q}(x) = \inf_{a \in (x)_\rho} \{\mu_{P \cap Q}(a)\}$$

$$\begin{aligned}
&= \inf_{a \in (x)_\rho} \{(\mu_P \cap \mu_Q)(a)\} \\
&= \inf_{a \in (x)_\rho} \{\min\{\mu_P(a), \mu_Q(a)\}\} \\
&= \min\left\{ \inf_{a \in (x)_\rho} \{\mu_P(a)\}, \inf_{a \in (x)_\rho} \{\mu_Q(a)\} \right\} \quad (\text{Proposition 2.0.10 (1)}) \\
&= \min\{\underline{\mu}_P(x), \underline{\mu}_Q(x)\} \\
&= (\underline{\mu}_P \cap \underline{\mu}_Q)(x)
\end{aligned}$$

and

$$\begin{aligned}
\underline{\nu}_{P \cap Q}(x) &= \sup_{a \in (x)_\rho} \{\nu_{P \cap Q}(a)\} \\
&= \sup_{a \in (x)_\rho} \{(\nu_P \cup \nu_Q)(a)\} \\
&= \sup_{a \in (x)_\rho} \{\max\{\nu_P(a), \nu_Q(a)\}\} \\
&= \max\left\{ \sup_{a \in (x)_\rho} \{\nu_P(a)\}, \sup_{a \in (x)_\rho} \{\nu_Q(a)\} \right\} \quad (\text{Proposition 2.0.10 (2)}) \\
&= \max\{\underline{\nu}_P(x), \underline{\nu}_Q(x)\} \\
&= (\underline{\nu}_P \cup \underline{\nu}_Q)(x).
\end{aligned}$$

Hence, $\rho^-(P \cap Q) = \rho^-(P) \cap \rho^-(Q)$. □

Lemma 3.3.4 *If ρ is an equivalence relation on a nonempty set X and $P = (\mu_P, \nu_P)$ a Pythagorean fuzzy set in X , then*

$$(\forall x, y \in X)(x\rho y \Rightarrow \bar{\mu}_P(x) = \bar{\mu}_P(y)), \quad (3.3.1)$$

$$(\forall x, y \in X)(x\rho y \Rightarrow \bar{\nu}_P(x) = \bar{\nu}_P(y)), \quad (3.3.2)$$

$$(\forall x, y \in X)(x\rho y \Rightarrow \underline{\mu}_P(x) = \underline{\mu}_P(y)), \quad (3.3.3)$$

$$(\forall x, y \in X)(x\rho y \Rightarrow \underline{\nu}_P(x) = \underline{\nu}_P(y)). \quad (3.3.4)$$

Proof. Let $x, y \in X$ be such that $x\rho y$. Then

$$\begin{aligned}\bar{\mu}_P(x) &= \sup_{a \in (x)_\rho} \{\mu_P(a)\} = \sup_{b \in (y)_\rho} \{\mu_P(b)\} = \bar{\mu}_P(y), \\ \bar{\nu}_P(x) &= \inf_{a \in (x)_\rho} \{\nu_P(a)\} = \inf_{b \in (y)_\rho} \{\nu_P(b)\} = \bar{\nu}_P(y), \\ \underline{\mu}_P(x) &= \inf_{a \in (x)_\rho} \{\mu_P(a)\} = \inf_{b \in (y)_\rho} \{\mu_P(b)\} = \underline{\mu}_P(y), \\ \underline{\nu}_P(x) &= \sup_{a \in (x)_\rho} \{\nu_P(a)\} = \sup_{b \in (y)_\rho} \{\nu_P(b)\} = \underline{\nu}_P(y).\end{aligned}$$

We complete the proof. □

Theorem 3.3.5 *Let ρ be an congruence relation on a BCC-algebra $X = (X, \cdot, 0)$ and $P = (\mu_P, \nu_P)$ a Pythagorean fuzzy set in X . Then the following statements hold:*

- (1) *if P is a Pythagorean fuzzy BCC-subalgebra of X and ρ is complete, then $\rho^-(P)$ is a Pythagorean fuzzy BCC-subalgebra of X ,*
- (2) *if P is a Pythagorean fuzzy near BCC-filter of X and ρ is complete, then $\rho^-(P)$ is a Pythagorean fuzzy near BCC-filter of X ,*
- (3) *if P is a Pythagorean fuzzy BCC-filter of X and $(0)_\rho = \{0\}$, then $\rho^-(P)$ is a Pythagorean fuzzy BCC-filter of X ,*
- (4) *if P is a Pythagorean fuzzy implicative BCC-filter of X , $(0)_\rho = \{0\}$, and ρ is complete, then $\rho^-(P)$ is a Pythagorean fuzzy implicative BCC-filter of X ,*
- (5) *if P is a Pythagorean fuzzy comparative BCC-filter of X and $(0)_\rho = \{0\}$, then $\rho^-(P)$ is a Pythagorean fuzzy comparative BCC-filter of X ,*
- (6) *if P is a Pythagorean fuzzy shift BCC-filter of X , $(0)_\rho = \{0\}$, and ρ is complete, then $\rho^-(P)$ is a Pythagorean fuzzy shift BCC-filter of X .*
- (7) *if P is a Pythagorean fuzzy BCC-ideal of X , $(0)_\rho = \{0\}$, and ρ is complete, then $\rho^-(P)$ is a Pythagorean fuzzy BCC-ideal of X , and*

- (8) if P is a Pythagorean fuzzy strong BCC-ideal of X , then $\rho^-(P)$ is a Pythagorean fuzzy strong BCC-ideal of X .

Proof. (1) Assume that P is a Pythagorean fuzzy BCC-subalgebra of X and ρ complete. Then for all $x, y \in X$,

$$\begin{aligned}
\underline{\mu}_P(x \cdot y) &= \inf_{c \in (x \cdot y)_\rho} \{\mu_P(c)\} \\
&= \inf_{c \in (x)_\rho (y)_\rho} \{\mu_P(c)\} \\
&= \inf_{a \cdot b \in (x)_\rho (y)_\rho} \{\mu_P(a \cdot b)\} \\
&\geq \inf_{a \in (x)_\rho, b \in (y)_\rho} \{\min\{\mu_P(a), \mu_P(b)\}\} && ((3.1.1)) \\
&= \min\left\{ \inf_{a \in (x)_\rho} \{\mu_P(a)\}, \inf_{b \in (y)_\rho} \{\mu_P(b)\} \right\} && (\text{Proposition 2.0.10 (1)}) \\
&= \min\{\underline{\mu}_P(x), \underline{\mu}_P(y)\}
\end{aligned}$$

and

$$\begin{aligned}
\underline{\nu}_P(x \cdot y) &= \sup_{c \in (x \cdot y)_\rho} \{\nu_P(c)\} \\
&= \sup_{c \in (x)_\rho (y)_\rho} \{\nu_P(c)\} \\
&= \sup_{a \cdot b \in (x)_\rho (y)_\rho} \{\nu_P(a \cdot b)\} \\
&\leq \sup_{a \in (x)_\rho, b \in (y)_\rho} \{\max\{\nu_P(a), \nu_P(b)\}\} && ((3.1.2)) \\
&= \max\left\{ \sup_{a \in (x)_\rho} \{\nu_P(a)\}, \sup_{b \in (y)_\rho} \{\nu_P(b)\} \right\} && (\text{Proposition 2.0.10 (2)}) \\
&= \max\{\underline{\nu}_P(x), \underline{\nu}_P(y)\}.
\end{aligned}$$

Hence, $\rho^-(P)$ is a Pythagorean fuzzy BCC-subalgebra of X .

- (2) Assume that P is a Pythagorean fuzzy near BCC-filter of X and ρ

complete. Then for all $x, y \in X$,

$$\begin{aligned}
 \underline{\mu}_P(x \cdot y) &= \inf_{c \in (x \cdot y)_\rho} \{\mu_P(c)\} \\
 &= \inf_{c \in (x)_\rho (y)_\rho} \{\mu_P(c)\} \\
 &= \inf_{a \cdot b \in (x)_\rho (y)_\rho} \{\mu_P(a \cdot b)\} \\
 &\geq \inf_{b \in (y)_\rho} \{\mu_P(b)\} \\
 &= \underline{\mu}_P(y)
 \end{aligned} \tag{3.1.3}$$

and

$$\begin{aligned}
 \underline{\nu}_P(x \cdot y) &= \sup_{c \in (x \cdot y)_\rho} \{\nu_P(c)\} \\
 &= \sup_{c \in (x)_\rho (y)_\rho} \{\nu_P(c)\} \\
 &= \sup_{a \cdot b \in (x)_\rho (y)_\rho} \{\nu_P(a \cdot b)\} \\
 &\leq \sup_{b \in (y)_\rho} \{\nu_P(b)\} \\
 &= \underline{\nu}_P(y).
 \end{aligned} \tag{3.1.4}$$

Hence, $\rho^-(P)$ is a Pythagorean fuzzy near BCC-filter of X .

(3) Assume that P is a Pythagorean fuzzy BCC-filter of X and $(0)_\rho = \{0\}$. Then for all $x, y \in X$,

$$\underline{\mu}_P(0) = \inf_{a \in (0)_\rho} \{\mu_P(a)\} = \mu_P(0) \geq \mu_P(b) \geq \inf_{b \in (x)_\rho} \{\mu_P(b)\} = \underline{\mu}_P(x),$$

$$\underline{\nu}_P(0) = \sup_{a \in (0)_\rho} \{\nu_P(a)\} = \nu_P(0) \leq \nu_P(b) \leq \sup_{b \in (x)_\rho} \{\nu_P(b)\} = \underline{\nu}_P(x),$$

$$\underline{\mu}_P(y) = \inf_{b \in (y)_\rho} \{\mu_P(b)\}$$

$$\begin{aligned}
&\geq \inf_{a \cdot b \in (x)_\rho(y)_\rho, a \in (x)_\rho} \{\min\{\mu_P(a \cdot b), \mu_P(a)\}\} && ((3.1.7)) \\
&\geq \inf_{a \cdot b \in (x \cdot y)_\rho, a \in (x)_\rho} \{\min\{\mu_P(a \cdot b), \mu_P(a)\}\} \\
&= \min\left\{ \inf_{a \cdot b \in (x \cdot y)_\rho} \{\mu_P(a \cdot b)\}, \inf_{a \in (x)_\rho} \{\mu_P(a)\} \right\} && (\text{Proposition 2.0.10 (1)}) \\
&= \min\{\underline{\mu}_P(x \cdot y), \underline{\mu}_P(x)\},
\end{aligned}$$

and

$$\begin{aligned}
\underline{\nu}_P(y) &= \sup_{b \in (y)_\rho} \{\nu_P(b)\} \\
&\leq \sup_{a \cdot b \in (x)_\rho(y)_\rho, a \in (x)_\rho} \{\max\{\nu_P(a \cdot b), \nu_P(a)\}\} && ((3.1.8)) \\
&\leq \sup_{a \cdot b \in (x \cdot y)_\rho, a \in (x)_\rho} \{\max\{\nu_P(a \cdot b), \nu_P(a)\}\} \\
&= \max\left\{ \sup_{a \cdot b \in (x \cdot y)_\rho} \{\nu_P(a \cdot b)\}, \sup_{a \in (x)_\rho} \{\nu_P(a)\} \right\} && (\text{Proposition 2.0.10 (2)}) \\
&= \max\{\underline{\nu}_P(x \cdot y), \underline{\nu}_P(x)\}.
\end{aligned}$$

Hence, $\rho^-(P)$ is a Pythagorean fuzzy BCC-filter of X .

(4) Assume that P is a Pythagorean fuzzy implicative BCC-filter of X , $(0)_\rho = \{0\}$, and ρ is complete. Then for all $x, y \in X$,

$$\begin{aligned}
\underline{\mu}_P(0) &= \inf_{a \in (0)_\rho} \{\mu_P(a)\} = \mu_P(0) \geq \mu_P(x) \geq \inf_{b \in (x)_\rho} \{\mu_P(b)\} = \underline{\mu}_P(x), \\
\underline{\nu}_P(0) &= \sup_{a \in (0)_\rho} \{\nu_P(a)\} = \nu_P(0) \leq \nu_P(x) \leq \sup_{b \in (x)_\rho} \{\nu_P(b)\} = \underline{\nu}_P(x),
\end{aligned}$$

$$\begin{aligned}
&\underline{\mu}_P(x \cdot z) \\
&= \inf_{d \in (x \cdot z)_\rho} \{\mu_P(d)\} \\
&= \inf_{d \in (x)_\rho(z)_\rho} \{\mu_P(d)\} && (\rho \text{ is complete})
\end{aligned}$$

$$\begin{aligned}
&= \inf_{a \cdot c \in (x)_\rho(z)_\rho} \{\mu_P(a \cdot c)\} \\
&\geq \inf_{a \cdot (b \cdot c) \in (x)_\rho((y)_\rho(z)_\rho), a \cdot b \in (x)_\rho(y)_\rho} \{\min\{\mu_P(a \cdot (b \cdot c)), \mu_P(a \cdot b)\}\} \quad ((3.1.9)) \\
&= \inf_{a \cdot (b \cdot c) \in (x \cdot (y \cdot z))_\rho, a \cdot b \in (x \cdot y)_\rho} \{\min\{\mu_P(a \cdot (b \cdot c)), \mu_P(a \cdot b)\}\} \quad (\rho \text{ is complete}) \\
&= \min\left\{ \inf_{a \cdot (b \cdot c) \in (x \cdot (y \cdot z))_\rho} \mu_P(a \cdot (b \cdot c)), \inf_{a \cdot b \in (x \cdot y)_\rho} \{\mu_P(a \cdot b)\} \right\} \quad (\text{Proposition 2.0.10 (1)}) \\
&= \min\{\underline{\mu}_P(x \cdot (y \cdot z)), \underline{\mu}_P(x \cdot y)\},
\end{aligned}$$

and

$$\begin{aligned}
&\underline{\nu}_P(x \cdot z) \\
&= \sup_{d \in (x \cdot z)_\rho} \{\nu_P(d)\} \\
&= \sup_{d \in (x)_\rho(z)_\rho} \{\nu_P(d)\} \quad (\rho \text{ is complete}) \\
&= \sup_{a \cdot c \in (x)_\rho(z)_\rho} \{\nu_P(a \cdot c)\} \\
&\leq \sup_{a \cdot (b \cdot c) \in (x)_\rho((y)_\rho(z)_\rho), a \cdot b \in (x)_\rho(y)_\rho} \{\max\{\nu_P(a \cdot (b \cdot c)), \nu_P(a \cdot b)\}\} \quad ((3.1.10)) \\
&= \sup_{a \cdot (b \cdot c) \in (x \cdot (y \cdot z))_\rho, a \cdot b \in (x \cdot y)_\rho} \{\max\{\nu_P(a \cdot (b \cdot c)), \nu_P(a \cdot b)\}\} \quad (\rho \text{ is complete}) \\
&= \max\left\{ \sup_{a \cdot (b \cdot c) \in (x \cdot (y \cdot z))_\rho} \nu_P(a \cdot (b \cdot c)), \sup_{a \cdot b \in (x \cdot y)_\rho} \{\nu_P(a \cdot b)\} \right\} \quad (\text{Proposition 2.0.10 (2)}) \\
&= \max\{\underline{\nu}_P(x \cdot (y \cdot z)), \underline{\nu}_P(x \cdot y)\}.
\end{aligned}$$

Hence, $\rho^-(P)$ is a Pythagorean fuzzy implicative BCC-filter of X .

(5) Assume that P is a Pythagorean fuzzy comparative BCC-filter of X and $(0)_\rho = \{0\}$. Then for all $x, y \in X$,

$$\underline{\mu}_P(0) = \inf_{a \in (0)_\rho} \{\mu_P(a)\} = \mu_P(0) \geq \mu_P(x) \geq \inf_{b \in (x)_\rho} \{\mu_P(b)\} = \underline{\mu}_P(x),$$

$$\underline{\nu}_P(0) = \sup_{a \in (0)_\rho} \{\nu_P(a)\} = \nu_P(0) \leq \nu_P(x) \leq \sup_{b \in (x)_\rho} \{\nu_P(b)\} = \underline{\nu}_P(x),$$

$$\begin{aligned}
& \underline{\mu}_P(y) \\
&= \inf_{b \in (y)_\rho} \{\mu_P(b)\} \\
&\geq \inf_{a \cdot ((b \cdot c) \cdot b) \in (x)_\rho, ((y)_\rho(z)_\rho)(y)_\rho, a \in (x)_\rho} \{\min\{\mu_P(a \cdot ((b \cdot c) \cdot b)), \mu_P(a)\}\} \quad ((3.1.11)) \\
&\geq \inf_{a \cdot ((b \cdot c) \cdot b) \in (x \cdot ((y \cdot z) \cdot y))_\rho, a \in (x)_\rho} \{\min\{\mu_P(a \cdot ((b \cdot c) \cdot b)), \mu_P(a)\}\} \quad (\rho \text{ is congruence}) \\
&= \min\left\{ \inf_{a \cdot ((b \cdot c) \cdot b) \in (x \cdot ((y \cdot z) \cdot y))_\rho} \{\mu_P(a \cdot ((b \cdot c) \cdot b))\} \right. \\
&\quad \left. , \inf_{a \in (x)_\rho} \{\mu_P(a)\} \right\} \quad (\text{Proposition 2.0.10 (1)}) \\
&= \min\{\underline{\mu}_P(x \cdot ((y \cdot z) \cdot y)), \underline{\mu}_P(x)\},
\end{aligned}$$

and

$$\begin{aligned}
& \underline{\nu}_P(y) \\
&= \sup_{b \in (y)_\rho} \{\nu_P(b)\} \\
&\leq \sup_{a \cdot ((b \cdot c) \cdot b) \in (x)_\rho, ((y)_\rho(z)_\rho)(y)_\rho, a \in (x)_\rho} \{\max\{\nu_P(a \cdot ((b \cdot c) \cdot b)), \nu_P(a)\}\} \quad ((3.1.12)) \\
&\leq \sup_{a \cdot ((b \cdot c) \cdot b) \in (x \cdot ((y \cdot z) \cdot y))_\rho, a \in (x)_\rho} \{\max\{\nu_P(a \cdot ((b \cdot c) \cdot b)), \nu_P(a)\}\} \quad (\rho \text{ is congruence}) \\
&= \max\left\{ \sup_{a \cdot ((b \cdot c) \cdot b) \in (x \cdot ((y \cdot z) \cdot y))_\rho} \{\nu_P(a \cdot ((b \cdot c) \cdot b))\} \right. \\
&\quad \left. , \sup_{a \in (x)_\rho} \{\nu_P(a)\} \right\} \quad (\text{Proposition 2.0.10 (2)}) \\
&= \max\{\underline{\nu}_P(x \cdot ((y \cdot z) \cdot y)), \underline{\nu}_P(x)\}.
\end{aligned}$$

Hence, $\rho^-(P)$ is a Pythagorean fuzzy comparative BCC-filter of X .

(6) Assume that P is a Pythagorean fuzzy shift BCC-filter of X , $(0)_\rho =$

$\{0\}$, and ρ is complete. Then for all $x, y \in X$,

$$\underline{\mu}_P(0) = \inf_{a \in (0)_\rho} \{\mu_P(a)\} = \mu_P(0) \geq \mu_P(x) \geq \inf_{b \in (x)_\rho} \{\mu_P(b)\} = \underline{\mu}_P(x),$$

$$\underline{\nu}_P(0) = \sup_{a \in (0)_\rho} \{\nu_P(a)\} = \nu_P(0) \leq \nu_P(x) \leq \sup_{b \in (x)_\rho} \{\nu_P(b)\} = \underline{\nu}_P(x),$$

$$\begin{aligned} & \underline{\mu}_P(((z \cdot y) \cdot y) \cdot z) \\ &= \inf_{d \in (((z \cdot y) \cdot y) \cdot z)_\rho} \{\mu_P(d)\} \\ &= \inf_{d \in (((z)_\rho(y)_\rho)(y)_\rho)(z)_\rho} \{\mu_P(d)\} && (\rho \text{ is complete}) \\ &= \inf_{((c \cdot b) \cdot b) \cdot c \in (((z)_\rho(y)_\rho)(y)_\rho)(z)_\rho} \{\mu_P(((c \cdot b) \cdot b) \cdot c)\} \\ &\geq \inf_{a \cdot (b \cdot c) \in (x)_\rho, (y)_\rho(z)_\rho, a \in (x)_\rho} \{\min\{\mu_P(a \cdot (b \cdot c)), \mu_P(a)\}\} && ((3.1.13)) \\ &= \inf_{a \cdot (b \cdot c) \in (x \cdot (y \cdot z))_\rho, a \cdot b \in (x \cdot y)_\rho} \{\min\{\mu_P(a \cdot (b \cdot c)), \mu_P(a \cdot b)\}\} && (\rho \text{ is complete}) \\ &= \min\left\{ \inf_{a \cdot (b \cdot c) \in (x \cdot (y \cdot z))_\rho} \mu_P(a \cdot (b \cdot c)), \inf_{a \in (x)_\rho} \{\mu_P(a)\} \right\} && (\text{Proposition 2.0.10 (1)}) \\ &= \min\{\underline{\mu}_P(x \cdot (y \cdot z)), \underline{\mu}_P(x)\}, \end{aligned}$$

and

$$\begin{aligned} & \underline{\nu}_P(((z \cdot y) \cdot y) \cdot z) \\ &= \sup_{d \in (((z \cdot y) \cdot y) \cdot z)_\rho} \{\nu_P(d)\} \\ &= \sup_{d \in (((z)_\rho(y)_\rho)(y)_\rho)(z)_\rho} \{\nu_P(d)\} && (\rho \text{ is complete}) \\ &= \sup_{((c \cdot b) \cdot b) \cdot c \in (((z)_\rho(y)_\rho)(y)_\rho)(z)_\rho} \{\nu_P(((c \cdot b) \cdot b) \cdot c)\} \\ &\leq \sup_{a \cdot (b \cdot c) \in (x)_\rho, (y)_\rho(z)_\rho, a \in (x)_\rho} \{\max\{\nu_P(a \cdot (b \cdot c)), \nu_P(a)\}\} && ((3.1.14)) \\ &= \sup_{a \cdot (b \cdot c) \in (x \cdot (y \cdot z))_\rho, a \in (x)_\rho} \{\max\{\nu_P(a \cdot (b \cdot c)), \nu_P(a)\}\} && (\rho \text{ is complete}) \end{aligned}$$

$$\begin{aligned}
&= \max\left\{\sup_{a \cdot (b \cdot c) \in (x \cdot (y \cdot z))_\rho} \nu_P(a \cdot (b \cdot c)), \sup_{a \in (x)_\rho} \{\nu_P(a)\}\right\} \quad (\text{Proposition 2.0.10 (2)}) \\
&= \max\{\underline{\nu}_P(x \cdot (y \cdot z)), \underline{\nu}_P(x)\}.
\end{aligned}$$

Hence, $\rho^-(P)$ is a Pythagorean fuzzy shift BCC-filter of X .

(7) Assume that P is a Pythagorean fuzzy BCC-ideal of X , ρ a complete, and $(0)_\rho = \{0\}$. Then for all $x, y, z \in X$,

$$\underline{\mu}_P(0) = \inf_{a \in (0)_\rho} \{\mu_P(a)\} = \mu_P(0) \geq \mu_P(b) \geq \inf_{b \in (x)_\rho} \{\mu_P(b)\} = \underline{\mu}_P(x),$$

$$\underline{\nu}_P(0) = \sup_{a \in (0)_\rho} \{\nu_P(a)\} = \nu_P(0) \leq \nu_P(b) \leq \sup_{b \in (x)_\rho} \{\nu_P(b)\} = \underline{\nu}_P(x),$$

$$\begin{aligned}
&\underline{\mu}_P(x \cdot z) \\
&= \inf_{d \in (x \cdot z)_\rho} \{\mu_P(d)\} \\
&= \inf_{d \in (x)_\rho (z)_\rho} \{\mu_P(d)\} \\
&= \inf_{a \cdot c \in (x)_\rho (z)_\rho} \{\mu_P(a \cdot c)\} \\
&\geq \inf_{a \cdot (b \cdot c) \in (x)_\rho ((y)_\rho (z)_\rho), b \in (y)_\rho} \{\min\{\mu_P(a \cdot (b \cdot c)), \mu_P(b)\}\} \quad ((3.1.15)) \\
&= \inf_{a \cdot (b \cdot c) \in (x \cdot (y \cdot z))_\rho, b \in (y)_\rho} \{\min\{\mu_P(a \cdot (b \cdot c)), \mu_P(b)\}\} \\
&= \min\left\{\inf_{a \cdot (b \cdot c) \in (x \cdot (y \cdot z))_\rho} \{\mu_P(a \cdot (b \cdot c))\}, \inf_{b \in (y)_\rho} \{\mu_P(b)\}\right\} \quad (\text{Proposition 2.0.10 (1)}) \\
&= \min\{\underline{\mu}_P(x \cdot (y \cdot z)), \underline{\mu}_P(y)\},
\end{aligned}$$

and

$$\begin{aligned}
&\underline{\nu}_P(x \cdot z) \\
&= \sup_{d \in (x \cdot z)_\rho} \{\nu_P(d)\}
\end{aligned}$$

$$\begin{aligned}
&= \sup_{d \in (x)_\rho(z)_\rho} \{\nu_P(d)\} \\
&= \sup_{a \cdot c \in (x)_\rho(z)_\rho} \{\nu_P(a \cdot c)\} \\
&\leq \sup_{a \cdot (b \cdot c) \in (x)_\rho((y)_\rho(z)_\rho), b \in (y)_\rho} \{\max\{\nu_P(a \cdot (b \cdot c)), \nu_P(b)\}\} \quad ((3.1.16)) \\
&= \sup_{a \cdot (b \cdot c) \in (x \cdot (y \cdot z))_\rho, b \in (y)_\rho} \{\max\{\nu_P(a \cdot (b \cdot c)), \nu_P(b)\}\} \\
&= \max\left\{ \sup_{a \cdot (b \cdot c) \in (x \cdot (y \cdot z))_\rho} \{\nu_P(a \cdot (b \cdot c))\}, \sup_{b \in (y)_\rho} \{\nu_P(b)\} \right\} \quad (\text{Proposition 2.0.10 (2)}) \\
&= \max\{\underline{\nu}_P(x \cdot (y \cdot z)), \underline{\nu}_P(y)\}.
\end{aligned}$$

Hence, $\rho^-(P)$ is a Pythagorean fuzzy BCC-ideal of X .

(8) Assume that P is a Pythagorean fuzzy strong BCC-ideal of X . By Theorem 3.1.2, we have P is constant. Then for all $x, y, z \in X$,

$$\begin{aligned}
\underline{\mu}_P(0) &= \inf_{a \in (0)_\rho} \{\mu_P(a)\} = \inf_{b \in (x)_\rho} \{\mu_P(b)\} = \underline{\mu}_P(x), \\
\underline{\nu}_P(0) &= \sup_{a \in (0)_\rho} \{\nu_P(a)\} = \sup_{b \in (x)_\rho} \{\nu_P(b)\} = \underline{\nu}_P(x), \\
\underline{\mu}_P(x) &= \inf_{a \in (x)_\rho} \{\mu_P(a)\} \\
&\geq \inf_{(c \cdot b) \cdot (c \cdot a) \in ((z)_\rho(y)_\rho)((z)_\rho(x)_\rho), b \in (y)_\rho} \{\min\{\mu_P((c \cdot b) \cdot (c \cdot a)), \mu_P(b)\}\} \quad ((3.1.17)) \\
&\geq \inf_{(c \cdot b) \cdot (c \cdot a) \in ((z \cdot y) \cdot (z \cdot x))_\rho, b \in (y)_\rho} \{\min\{\mu_P((c \cdot b) \cdot (c \cdot a)), \mu_P(b)\}\} \\
&= \min\left\{ \inf_{(c \cdot b) \cdot (c \cdot a) \in ((z \cdot y) \cdot (z \cdot x))_\rho} \{\mu_P((c \cdot b) \cdot (c \cdot a))\} \right. \\
&\quad \left. , \inf_{b \in (y)_\rho} \{\mu_P(b)\} \right\} \quad (\text{Proposition 2.0.10 (1)}) \\
&= \min\{\underline{\mu}_P((z \cdot y) \cdot (z \cdot x)), \underline{\mu}_P(y)\},
\end{aligned}$$

and

$$\begin{aligned}
& \underline{\nu}_P(x) \\
&= \sup_{a \in (x)_\rho} \{\nu_P(a)\} \\
&\leq \sup_{(c \cdot b) \cdot (c \cdot a) \in ((z \cdot y)_\rho(y)_\rho)((z \cdot x)_\rho(x)_\rho), b \in (y)_\rho} \{\max\{\nu_P((c \cdot b) \cdot (c \cdot a)), \nu_P(b)\}\} \quad ((3.1.18)) \\
&\leq \sup_{(c \cdot b) \cdot (c \cdot a) \in ((z \cdot y) \cdot (z \cdot x))_\rho, b \in (y)_\rho} \{\max\{\nu_P((c \cdot b) \cdot (c \cdot a)), \nu_P(b)\}\} \\
&= \max\left\{ \sup_{(c \cdot b) \cdot (c \cdot a) \in ((z \cdot y) \cdot (z \cdot x))_\rho} \{\nu_P((c \cdot b) \cdot (c \cdot a))\} \right. \\
&\quad \left. , \sup_{b \in (y)_\rho} \{\nu_P(b)\} \right\} \quad (\text{Proposition 2.0.10 (2)}) \\
&= \max\{\underline{\nu}_P((z \cdot y) \cdot (z \cdot x)), \underline{\nu}_P(y)\}.
\end{aligned}$$

Hence, $\rho^-(P)$ is a Pythagorean fuzzy strong BCC-ideal of X . \square

The following example shows that Theorem 3.3.5 (3) may be not true if $(0)_\rho \neq \{0\}$.

Example 3.3.6 Let $X = \{0, 1, 2, 3\}$ be a BCC-algebra with a fixed element 0 and a binary operation \cdot defined by the following Cayley table:

\cdot	0	1	2	3
0	0	1	2	3
1	0	0	2	0
2	0	1	0	3
3	0	1	2	0

We define a Pythagorean fuzzy set $P = (\mu_P, \nu_P)$ with the membership function

μ_P and the non-membership function ν_P as follows:

X	0	1	2	3
μ_P	0.7	0.4	0.6	0.6
ν_P	0.2	0.6	0.3	0.3

Then $P = (\mu_P, \nu_P)$ is a Pythagorean fuzzy BCC-filter of X . Let

$$\rho = \{(0, 0), (1, 1), (2, 2), (3, 3), (0, 1), (1, 0), (0, 3), (3, 0)\}.$$

Then ρ is a congruence relation on X . Thus

$$(0)_\rho = (1)_\rho = (3)_\rho = \{0, 1, 3\}, (2)_\rho = \{2\}.$$

Since $\underline{\mu}_P(0) = \min\{\mu_P(0), \mu_P(1), \mu_P(3)\} = \min\{0.7, 0.4, 0.6\} = 0.4 \not\geq 0.6 = \mu_P(2) = \underline{\mu}_P(2)$ and $\underline{\nu}_P(0) = \max\{\nu_P(0), \nu_P(1), \nu_P(3)\} = \max\{0.2, 0.6, 0.3\} = 0.6 \not\leq 0.3 = \nu_P(2) = \underline{\nu}_P(2)$, we have $\rho^-(P)$ is not a Pythagorean fuzzy BCC-filter of X .

The following example shows that Theorem 3.3.5 (4) may be not true if $(0)_\rho \neq \{0\}$ and ρ is not complete.

Example 3.3.7 Let $X = \{0, 1, 2, 3\}$ be a BCC-algebra with a fixed element 0 and a binary operation \cdot defined by the following Cayley table:

\cdot	0	1	2	3
0	0	1	2	3
1	0	0	2	0
2	0	1	0	3
3	0	1	2	0

We define a Pythagorean fuzzy set $P = (\mu_P, \nu_P)$ with the membership function

μ_P and the non-membership function ν_P as follows:

X	0	1	2	3
μ_P	1	0.1	0.3	0.3
ν_P	0	0.5	0.2	0.2

Then $P = (\mu_P, \nu_P)$ is a Pythagorean fuzzy implicative BCC-filter of X . Let

$$\rho = \{(0, 0), (1, 1), (2, 2), (3, 3), (0, 1), (1, 0), (0, 3), (3, 0)\}.$$

Then ρ is a congruence relation on X . Thus

$$(0)_\rho = (1)_\rho = (3)_\rho = \{0, 1, 3\}, (2)_\rho = \{2\}.$$

But ρ is not complete because

$$\{0\} = \{2\}\{2\} = (2)_\rho(2)_\rho \neq (2 \cdot 2)_\rho = (0)_\rho = \{0, 1, 3\},$$

Since $\underline{\mu}_P(0) = \min\{\mu_P(0), \mu_P(1), \mu_P(3)\} = \min\{1, 0.1, 0.3\} = 0.1 \not\geq 0.3 = \mu_P(2) = \underline{\mu}_P(2)$ and $\underline{\nu}_P(0) = \max\{\nu_P(0), \nu_P(1), \nu_P(3)\} = \max\{0, 0.5, 0.2\} = 0 \not\leq 0.2 = \nu_P(2) = \underline{\nu}_P(2)$, we have $\rho^-(P)$ is not a Pythagorean fuzzy implicative BCC-filter of X .

The following example shows that Theorem 3.3.5 (5) may be not true if $(0)_\rho \neq \{0\}$ and ρ is not complete.

Example 3.3.8 Let $X = \{0, 1, 2, 3\}$ be a BCC-algebra with a fixed element 0

and a binary operation \cdot defined by the following Cayley table:

\cdot	0	1	2	3
0	0	1	2	3
1	0	0	2	3
2	0	1	0	3
3	0	1	2	0

We define a Pythagorean fuzzy set $P = (\mu_P, \nu_P)$ with the membership function μ_P and the non-membership function ν_P as follows:

X	0	1	2	3
μ_P	0.8	0.3	0.5	0.8
ν_P	0.2	0.9	0.7	0.2

Then $P = (\mu_P, \nu_P)$ is a Pythagorean fuzzy comparative BCC-filter of X . Let

$$\rho = \{(0, 0), (1, 1), (2, 2), (3, 3), (0, 2), (2, 0)\}.$$

Then ρ is a congruence relation on X . Thus

$$(0)_\rho = (2)_\rho = \{0, 2\}, (1)_\rho = \{1\}, (3)_\rho = \{3\}.$$

But ρ is not complete because

$$\{0\} = \{1\}\{1\} = (1)_\rho(1)_\rho \neq (1 \cdot 1)_\rho = (0)_\rho = \{0, 2\},$$

Since $\underline{\mu}_P(0) = \min\{\mu_P(0), \mu_P(2)\} = \min\{0.8, 0.5\} = 0.5 \not\geq 0.8 = \mu_P(3) = \underline{\mu}_P(3)$
and $\underline{\nu}_P(0) = \max\{\nu_P(0), \nu_P(2)\} = \max\{0.2, 0.7\} = 0.7 \not\leq 0.2 = \nu_P(3) = \underline{\nu}_P(3)$,
we have $\rho^-(P)$ is not a Pythagorean fuzzy comparative BCC-filter of X .

The following example shows that Theorem 3.3.5 (6) may be not true if $(0)_\rho \neq \{0\}$ and ρ is not complete.

Example 3.3.9 By Example 3.3.8, we define a Pythagorean fuzzy set $P = (\mu_P, \nu_P)$ with the membership function μ_P and the non-membership function ν_P as follows:

X	0	1	2	3
μ_P	1	0.2	0.1	0.5
ν_P	0	0.6	0.9	0.4

Then $P = (\mu_P, \nu_P)$ is a Pythagorean fuzzy shift BCC-filter of X . Let

$$\rho = \{(0, 0), (1, 1), (2, 2), (3, 3), (0, 2), (2, 0)\}.$$

Then ρ is a congruence relation on X . Thus

$$(0)_\rho = (2)_\rho = \{0, 2\}, (1)_\rho = \{1\}, (3)_\rho = \{3\}.$$

But ρ is not complete because

$$\{0\} = \{3\}\{3\} = (3)_\rho(3)_\rho \neq (3 \cdot 3)_\rho = (0)_\rho = \{0, 2\},$$

Since $\underline{\mu}_P(0) = \min\{\mu_P(0), \mu_P(2)\} = \min\{1, 0.1\} = 0.1 \not\geq 0.2 = \mu_P(1) = \underline{\mu}_P(1)$ and $\underline{\nu}_P(0) = \max\{\nu_P(0), \nu_P(2)\} = \max\{0, 0.9\} = 0.9 \not\leq 0.4 = \nu_P(3) = \underline{\nu}_P(3)$, we have $\rho^-(P)$ is not a Pythagorean fuzzy shift BCC-filter of X .

The following example shows that Theorem 3.3.5 (7) may be not true if $(0)_\rho \neq \{0\}$ and ρ is not complete.

Example 3.3.10 From Example 3.1.22, we define a Pythagorean fuzzy set $P = (\mu_P, \nu_P)$ with the membership function μ_P and the non-membership function ν_P

as follows:

X	0	1	2	3
μ_P	1	0.2	0.1	0.5
ν_P	0	0.6	0.9	0.4

Then $P = (\mu_P, \nu_P)$ is a Pythagorean fuzzy BCC-ideal of X . Let

$$\rho = \{(0, 0), (1, 1), (2, 2), (3, 3), (0, 2), (2, 0)\}.$$

Then ρ is a congruence relation on X . Thus

$$(0)_\rho = (2)_\rho = \{0, 2\}, (1)_\rho = \{1\}, (3)_\rho = \{3\}.$$

Since $\underline{\mu}_P(0) = \min\{\mu_P(0), \mu_P(2)\} = \min\{1, 0.1\} = 0.1 \not\geq 0.2 = \mu_P(1) = \underline{\mu}_P(1)$ and $\underline{\nu}_P(0) = \max\{\nu_P(0), \nu_P(2)\} = \max\{0, 0.9\} = 0.9 \not\leq 0.6 = \nu_P(1) = \underline{\nu}_P(1)$, we have $\rho^-(P)$ is not a Pythagorean fuzzy BCC-ideal of X .

Open Problem. Is the lower approximation $\rho^-(P)$ a Pythagorean fuzzy BCC-ideal of X if P is a Pythagorean fuzzy BCC-ideal, $(0)_\rho \neq \{0\}$, and ρ is complete?

Lemma 3.3.11 *If ρ is an congruence relation on a BCC-algebra $X = (X, \cdot, 0)$ and $P = (\mu_P, \nu_P)$ a Pythagorean fuzzy BCC-subalgebra of X , then the upper approximation $\rho^+(P)$ satisfies the following conditions:*

$$(\forall x \in X)(\bar{\mu}_P(0) \geq \bar{\mu}_P(x)), \quad (3.3.5)$$

$$(\forall x \in X)(\bar{\nu}_P(0) \leq \bar{\nu}_P(x)). \quad (3.3.6)$$

Proof. Let $x \in X$. Then

$$\bar{\mu}_P(0) = \sup_{a \in (0)_\rho} \{\mu_P(a)\}$$

$$\begin{aligned}
&\geq \mu_P(0) \\
&\geq \sup_{b \in (x)_\rho} \{\mu_P(b)\} \\
&= \bar{\mu}_P(x)
\end{aligned} \tag{3.1.5}$$

and

$$\begin{aligned}
\bar{\nu}_P(0) &= \inf_{a \in (0)_\rho} \{\nu_P(a)\} \\
&\leq \nu_P(0) \\
&\leq \inf_{b \in (x)_\rho} \{\nu_P(b)\} \\
&= \bar{\nu}_P(x).
\end{aligned} \tag{3.1.6}$$

□

Theorem 3.3.12 *Let ρ be an congruence relation on a BCC-algebra $X = (X, \cdot, 0)$ and $P = (\mu_P, \nu_P)$ a Pythagorean fuzzy set in X . Then the following statements hold:*

- (1) *If P is a Pythagorean fuzzy BCC-subalgebra of X , then $\rho^+(P)$ is a Pythagorean fuzzy BCC-subalgebra of X ,*
- (2) *If P is a Pythagorean fuzzy near BCC-filter of X , then $\rho^+(P)$ is a Pythagorean fuzzy near BCC-filter of X , and*
- (3) *If P is a Pythagorean fuzzy strong BCC-ideal of X , then $\rho^+(P)$ is a Pythagorean fuzzy strong BCC-ideal of X .*

Proof. (1) Assume that P is a Pythagorean fuzzy BCC-subalgebra of X . Then for all $x, y \in X$,

Case 1: $x = y$. Then

$$\bar{\mu}_P(x \cdot y) = \bar{\mu}_P(0) \quad ((2.0.1))$$

$$\geq \bar{\mu}_P(x) \quad ((3.3.5))$$

$$\geq \min\{\bar{\mu}_P(x), \bar{\mu}_P(y)\}$$

and

$$\bar{\nu}_P(x \cdot y) = \bar{\nu}_P(0) \quad ((2.0.1))$$

$$\leq \bar{\nu}_P(x) \quad ((3.3.6))$$

$$\leq \max\{\bar{\nu}_P(x), \bar{\nu}_P(y)\}.$$

Case 2: $x \neq y$.

Case 2.1: $x \cdot y = x$ or y . It is sufficient to assume that $x \cdot y = x$. Then

$$\bar{\mu}_P(x \cdot y) = \bar{\mu}_P(x) \geq \min\{\bar{\mu}_P(x), \bar{\mu}_P(y)\}$$

and

$$\bar{\nu}_P(x \cdot y) = \bar{\nu}_P(x) \leq \max\{\bar{\nu}_P(x), \bar{\nu}_P(y)\}.$$

Case 2.2: $x \cdot y \neq x$ and $x \cdot y \neq y$. Assume that there exists $z \in X$ be such that $x \cdot y = z$. If $z \rho 0$, then

$$\bar{\mu}_P(x \cdot y) = \bar{\mu}_P(z) = \bar{\mu}_P(0) \geq \min\{\bar{\mu}_P(x), \bar{\mu}_P(y)\} \quad ((3.3.1))$$

and

$$\bar{\nu}_P(x \cdot y) = \bar{\nu}_P(z) = \bar{\nu}_P(0) \leq \max\{\bar{\nu}_P(x), \bar{\nu}_P(y)\}. \quad ((3.3.2))$$

If $x\rho 0$ or $y\rho 0$, it is sufficient to assume that $x\rho 0$. Since ρ is a congruence relation on X , we have $xy\rho 0y$, that is, $z\rho y$. Therefore,

$$\begin{aligned}\bar{\mu}_P(x \cdot y) &= \bar{\mu}_P(z) \\ &= \bar{\mu}_P(y)\end{aligned}\tag{(3.3.1)}$$

$$= \min\{\bar{\mu}_P(0), \bar{\mu}_P(y)\}\tag{(3.3.5)}$$

$$= \min\{\bar{\mu}_P(x), \bar{\mu}_P(y)\}\tag{(3.3.1)}$$

and

$$\begin{aligned}\bar{\nu}_P(x \cdot y) &= \bar{\nu}_P(z) \\ &= \bar{\nu}_P(y)\end{aligned}\tag{(3.3.2)}$$

$$= \min\{\bar{\nu}_P(0), \bar{\nu}_P(y)\}\tag{(3.3.6)}$$

$$= \max\{\bar{\nu}_P(x), \bar{\nu}_P(y)\}.\tag{(3.3.2)}$$

Hence, $\rho^+(P)$ is a Pythagorean fuzzy BCC-subalgebra of X .

(2) Assume that P is a Pythagorean fuzzy near BCC-filter of X . Then for all $x, y \in X$,

$$\begin{aligned}\bar{\mu}_P(x \cdot y) &= \sup_{c \in (x \cdot y)_\rho} \{\mu_P(c)\} \\ &\geq \sup_{c \in (x)_\rho (y)_\rho} \{\mu_P(c)\} \\ &= \sup_{a \cdot b \in (x)_\rho (y)_\rho} \{\mu_P(a \cdot b)\} \\ &\geq \sup_{b \in (y)_\rho} \{\mu_P(b)\} \\ &= \bar{\mu}_P(y)\end{aligned}\tag{(3.1.3)}$$

and

$$\begin{aligned}
\bar{\nu}_P(x \cdot y) &= \inf_{c \in (x \cdot y)_\rho} \{\nu_P(c)\} \\
&\leq \inf_{c \in (x)_\rho (y)_\rho} \{\nu_P(c)\} \\
&= \inf_{a \cdot b \in (x)_\rho (y)_\rho} \{\nu_P(a \cdot b)\} \\
&\leq \inf_{b \in (y)_\rho} \{\nu_P(b)\} \\
&= \bar{\nu}_P(y).
\end{aligned} \tag{3.1.4}$$

Hence, $\rho^+(P)$ is a Pythagorean fuzzy near BCC-filter of X .

(3) Assume that P is a Pythagorean fuzzy strong BCC-ideal of X . By Theorem 3.1.2, we have P is constant. Then for all $x, y, z \in X$,

$$\begin{aligned}
\bar{\mu}_P(0) &= \sup_{a \in (0)_\rho} \{\mu_P(a)\} = \sup_{b \in (x)_\rho} \{\mu_P(b)\} = \bar{\mu}_P(x), \\
\bar{\nu}_P(0) &= \inf_{a \in (0)_\rho} \{\nu_P(a)\} = \inf_{b \in (x)_\rho} \{\nu_P(b)\} = \bar{\nu}_P(x),
\end{aligned}$$

$$\begin{aligned}
&\bar{\mu}_P(x) \\
&= \sup_{a \in (x)_\rho} \{\mu_P(a)\} \\
&\geq \sup_{(c \cdot b) \cdot (c \cdot a) \in ((z)_\rho (y)_\rho) ((z)_\rho (x)_\rho), b \in (y)_\rho} \{\min\{\mu_P((c \cdot b) \cdot (c \cdot a)), \mu_P(b)\}\} \\
&= \sup_{(c \cdot b) \cdot (c \cdot a) \in ((z \cdot y) \cdot (z \cdot x))_\rho, b \in (y)_\rho} \{\min\{\mu_P((c \cdot b) \cdot (c \cdot a)), \mu_P(b)\}\} \\
&= \min\left\{ \sup_{(c \cdot b) \cdot (c \cdot a) \in ((z \cdot y) \cdot (z \cdot x))_\rho} \{\mu_P((c \cdot b) \cdot (c \cdot a))\}, \sup_{b \in (y)_\rho} \{\mu_P(b)\} \right\} \quad (P \text{ is constant}) \\
&= \min\{\bar{\mu}_P((z \cdot y) \cdot (z \cdot x)), \bar{\mu}_P(y)\},
\end{aligned} \tag{3.1.17}$$

and

$$\begin{aligned}
& \bar{\nu}_P(x) \\
&= \inf_{a \in (x)_\rho} \{\nu_P(a)\} \\
&\leq \inf_{(c \cdot b) \cdot (c \cdot a) \in ((z \cdot y)_\rho (y)_\rho) ((z)_\rho (x)_\rho), b \in (y)_\rho} \{\max\{\nu_P((c \cdot b) \cdot (c \cdot a)), \nu_P(b)\}\} \quad ((3.1.18)) \\
&= \inf_{(c \cdot b) \cdot (c \cdot a) \in ((z \cdot y) \cdot (z \cdot x))_\rho, b \in (y)_\rho} \{\max\{\nu_P((c \cdot b) \cdot (c \cdot a)), \nu_P(b)\}\} \\
&= \max\left\{ \inf_{(c \cdot b) \cdot (c \cdot a) \in ((z \cdot y) \cdot (z \cdot x))_\rho} \{\nu_P((c \cdot b) \cdot (c \cdot a))\}, \inf_{b \in (y)_\rho} \{\nu_P(b)\} \right\} \quad (P \text{ is constant}) \\
&= \max\{\bar{\nu}_P((z \cdot y) \cdot (z \cdot x)), \bar{\nu}_P(y)\}.
\end{aligned}$$

Hence, $\rho^+(P)$ is a Pythagorean fuzzy strong BCC-ideal of X . \square

The following example shows that if P is a Pythagorean fuzzy BCC-filter of X , then the upper approximation $\rho^+(P)$ is not a Pythagorean fuzzy BCC-filter in general.

Example 3.3.13 From Example 3.2.8, we define a Pythagorean fuzzy set $P = (\mu_P, \nu_P)$ with the membership function μ_P and the non-membership function ν_P as follows:

X	0	1	2	3
μ_P	0.6	0.5	0.3	0.3
ν_P	0.3	0.4	0.7	0.7

Then $P = (\mu_P, \nu_P)$ is a Pythagorean fuzzy BCC-filter of X . Let

$$\rho = \{(0, 0), (1, 1), (2, 2), (3, 3), (3, 0), (0, 3)\}.$$

Then ρ is a congruence relation on X . Thus

$$(0)_\rho = (3)_\rho = \{0, 3\}, (1)_\rho = \{1\}, (2)_\rho = \{2\}.$$

Since $\bar{\mu}_P(2) = \mu_P(2) = 0.3 \not\geq 0.5 = \min\{\max\{\mu_P(0), \mu_P(3)\}, \mu_P(1)\} = \min\{\bar{\mu}_P(3), \bar{\mu}_P(1)\} = \min\{\bar{\mu}_P(1 \cdot 2), \bar{\mu}_P(1)\}$. we have $\rho^+(P)$ is not a Pythagorean fuzzy BCC-filter of X .

Open Problem. Is the upper approximation $\rho^+(P)$ a Pythagorean fuzzy BCC-filter of X if P is a Pythagorean fuzzy BCC-filter of X ?

By Theorem 3.3.5, we discussed about relation between Pythagorean fuzzy sets and lower approximations. Next, we study relation between Pythagorean fuzzy sets and upper approximations. We found the relation of them cannot prove in the same direction with Theorem 3.3.5. Hence, we assume that ρ be an equivalence relation on X and $P = (\mu_P, \nu_P)$ a Pythagorean fuzzy set in X , then the following examples show that if P is a Pythagorean fuzzy implicative (resp., comparative, shift) BCC-filter of X , then the upper approximation $\rho^+(P)$ is not a Pythagorean fuzzy implicative (resp., comparative, shift) BCC-filter in general.

Example 3.3.14 Let $X = \{0, 1, 2, 3\}$ be a BCC-algebra with a fixed element 0 and a binary operation \cdot defined by the following Cayley table:

\cdot	0	1	2	3
0	0	1	2	3
1	0	0	3	3
2	0	0	0	0
3	0	1	1	0

We define a Pythagorean fuzzy set $P = (\mu_P, \nu_P)$ with the membership function μ_P and the non-membership function ν_P as follows:

X	0	1	2	3
μ_P	0.6	0.5	0.3	0.3
ν_P	0.4	0.5	0.7	0.7

Then $P = (\mu_P, \nu_P)$ is a Pythagorean fuzzy implicative BCC-filter of X . Let

$$\rho = \{(0, 0), (1, 1), (2, 2), (3, 3), (0, 3), (3, 0)\}.$$

Then ρ is an equivalence relation on X . Thus

$$(0)_\rho = (3)_\rho = \{0, 3\}, (1)_\rho = \{1\}, (2)_\rho = \{2\}.$$

Since $\bar{\mu}_P(0 \cdot 2) = \bar{\mu}_P(2) = 0.3 \not\geq 0.5 = \min\{0.6, 0.5\} = \min\{\max\{0.6, 0.3\}, 0.5\} = \min\{\bar{\mu}_P(3), \bar{\mu}_P(1)\} = \min\{\bar{\mu}_P(0 \cdot (1 \cdot 2)), \bar{\mu}_P(0 \cdot 1)\}$, we have $\rho^+(P)$ is not a Pythagorean fuzzy implicative BCC-filter of X .

Example 3.3.15 From Example 3.3.14, we define a Pythagorean fuzzy set $P = (\mu_P, \nu_P)$ with the membership function μ_P and the non-membership function ν_P as follows:

X	0	1	2	3
μ_P	0.8	0.2	0.1	0.1
ν_P	0.2	0.6	0.9	0.9

Then $P = (\mu_P, \nu_P)$ is a Pythagorean fuzzy comparative BCC-filter of X . Let

$$\rho = \{(0, 0), (1, 1), (2, 2), (3, 3), (0, 3), (3, 0)\}.$$

Then ρ is an equivalence relation on X . Thus

$$(0)_\rho = (3)_\rho = \{0, 3\}, (1)_\rho = \{1\}, (2)_\rho = \{2\}.$$

Since $\bar{\mu}_P(2) = 0.1 \not\geq 0.2 = \min\{0.8, 0.2\} = \min\{\max\{0.8, 0.1\}, 0.2\} = \min\{\bar{\mu}_P(3), \bar{\mu}_P(1)\} = \min\{\bar{\mu}_P(1 \cdot ((2 \cdot 3) \cdot 2)), \bar{\mu}_P(1)\}$, we have $\rho^+(P)$ is not a Pythagorean fuzzy comparative BCC-filter of X .

Example 3.3.16 From Example 3.3.14, we define a Pythagorean fuzzy set $P =$

(μ_P, ν_P) with the membership function μ_P and the non-membership function ν_P as follows:

X	0	1	2	3
μ_P	0.9	0.8	0.2	0.2
ν_P	0.3	0.4	0.8	0.8

Then $P = (\mu_P, \nu_P)$ is a Pythagorean fuzzy shift BCC-filter of X . Let

$$\rho = \{(0, 0), (1, 1), (2, 2), (3, 3), (0, 3), (3, 0)\}.$$

Then ρ is an equivalence relation on X . Thus

$$(0)_\rho = (3)_\rho = \{0, 3\}, (1)_\rho = \{1\}, (2)_\rho = \{2\}.$$

Since $\bar{\mu}_P(((2 \cdot 0) \cdot 0) \cdot 2) = \bar{\mu}_P(2) = 0.2 \not\geq 0.8 = \min\{0.9, 0.8\} = \min\{\max\{0.9, 0.2\}, 0.8\} = \min\{\bar{\mu}_P(3), \bar{\mu}_P(1)\} = \min\{\bar{\mu}_P(1 \cdot (0 \cdot 2)), \bar{\mu}_P(1)\}$, we have $\rho^+(P)$ is not a Pythagorean fuzzy shift BCC-filter of X .

Open Problem. Is the upper approximation $\rho^+(P)$ a Pythagorean fuzzy implicative (resp., comparative, shift) BCC-filter of X if P is a Pythagorean fuzzy implicative (resp., comparative, shift) BCC-filter of X and ρ is congruence?

3.4 t -Level subsets of Pythagorean fuzzy sets

In this section, we shall discuss the relationships between Pythagorean fuzzy BCC-subalgebras (Pythagorean fuzzy near BCC-filters, Pythagorean fuzzy BCC-filters, Pythagorean fuzzy BCC-ideals, and Pythagorean fuzzy strong BCC-ideals) of BCC-algebras and their t -level subsets.

Definition 3.4.1 [47] Let F be a fuzzy set with the membership function μ_F in

X . The sets

$$\begin{aligned} U(\mu_F, t) &= \{x \in X \mid \mu_F(x) \geq t\}, \\ U^+(\mu_F, t) &= \{x \in X \mid \mu_F(x) > t\}, \\ L(\mu_F, t) &= \{x \in X \mid \mu_F(x) \leq t\}, \\ L^-(\mu_F, t) &= \{x \in X \mid \mu_F(x) < t\}, \\ E(\mu_F, t) &= \{x \in X \mid \mu_F(x) = t\} \end{aligned}$$

are referred to as an *upper t -level subset*, an *upper t -strong level subset*, a *lower t -level subset*, a *lower t -strong level subset*, and an *equal t -level subset* of F , respectively, for any $t \in [0, 1]$.

Theorem 3.4.2 P is a Pythagorean fuzzy BCC-subalgebra of X if and only if $U(\mu_P, t)$ and $L(\nu_P, t)$ are, if the sets are nonempty, BCC-subalgebras of X for every $t \in [0, 1]$.

Proof. Assume $P = (\mu_P, \nu_P)$ is a Pythagorean fuzzy BCC-subalgebra of X . Let $t \in [0, 1]$ be such that $U(\mu_P, t), L(\nu_P, t) \neq \emptyset$. Let $x, y \in X$. Then

$$\begin{aligned} x, y \in U(\mu_P, t) &\Rightarrow \mu_P(x) \geq t, \mu_P(y) \geq t \\ &\Rightarrow \min\{\mu_P(x), \mu_P(y)\} \geq t \\ &\Rightarrow \mu_P(x \cdot y) \geq \min\{\mu_P(x), \mu_P(y)\} \geq t \\ &\Rightarrow x \cdot y \in U(\mu_P, t) \end{aligned} \tag{3.1.1}$$

and

$$\begin{aligned} x, y \in L(\nu_P, t) &\Rightarrow \nu_P(x) \leq t, \nu_P(y) \leq t \\ &\Rightarrow \max\{\nu_P(x), \nu_P(y)\} \leq t \\ &\Rightarrow \nu_P(x \cdot y) \leq \max\{\nu_P(x), \nu_P(y)\} \leq t \end{aligned} \tag{3.1.2}$$

$$\Rightarrow x \cdot y \in L(\nu_P, t).$$

Hence, $U(\mu_P, t)$ and $L(\nu_P, t)$ are BCC-subalgebras of X .

Conversely, assume for all $t \in [0, 1]$, $U(\mu_P, t)$ and $L(\nu_P, t)$ are BCC-subalgebras of X if the sets are nonempty. Let $x, y \in X$.

Choose $t = \min\{\mu_P(x), \mu_P(y)\} \in [0, 1]$. Then $\mu_P(x) \geq t$ and $\mu_P(y) \geq t$. Thus $x, y \in U(\mu_P, t) \neq \emptyset$. As a hypothesis, we get $U(\mu_P, t)$ is a BCC-subalgebra of X and so $x \cdot y \in U(\mu_P, t)$. Thus $\mu_P(x \cdot y) \geq t = \min\{\mu_P(x), \mu_P(y)\}$.

Choose $t = \max\{\nu_P(x), \nu_P(y)\} \in [0, 1]$. Then $\nu_P(x) \leq t$ and $\nu_P(y) \leq t$. Thus $x, y \in L(\nu_P, t) \neq \emptyset$. As a hypothesis, we get $L(\nu_P, t)$ is a BCC-subalgebra of X and so $x \cdot y \in L(\nu_P, t)$. Thus $\nu_P(x \cdot y) \leq t = \max\{\nu_P(x), \nu_P(y)\}$.

Hence, P is a Pythagorean fuzzy BCC-subalgebra of X . □

Theorem 3.4.3 P is a Pythagorean fuzzy BCC-subalgebra of X if and only if $U^+(\mu_P, t)$ and $L^-(\nu_P, t)$ are, if the sets are nonempty, BCC-subalgebras of X for every $t \in [0, 1]$.

Proof. Assume $P = (\mu_P, \nu_P)$ is a Pythagorean fuzzy BCC-subalgebra of X . Let $t \in [0, 1]$ be such that $U^+(\mu_P, t), L^-(\nu_P, t) \neq \emptyset$. Let $x, y \in X$. Then

$$\begin{aligned} x, y \in U^+(\mu_P, t) &\Rightarrow \mu_P(x) > t, \mu_P(y) > t \\ &\Rightarrow \min\{\mu_P(x), \mu_P(y)\} > t \\ &\Rightarrow \mu_P(x \cdot y) \geq \min\{\mu_P(x), \mu_P(y)\} > t && ((3.1.1)) \\ &\Rightarrow x \cdot y \in U^+(\mu_P, t) \end{aligned}$$

and

$$\begin{aligned}
x, y \in L^-(\nu_P, t) &\Rightarrow \nu_P(x) < t, \nu_P(y) < t \\
&\Rightarrow \max\{\mu_P(x), \nu_P(y)\} < t \\
&\Rightarrow \nu_P(x \cdot y) \leq \max\{\nu_P(x), \nu_P(y)\} < t \quad ((3.1.2)) \\
&\Rightarrow x \cdot y \in L^-(\nu_P, t).
\end{aligned}$$

Hence, $U^+(\mu_P, t)$ and $L^-(\nu_P, t)$ are BCC-subalgebras of X .

Conversely, assume for all $t \in [0, 1]$, $U^+(\mu_P, t)$ and $L^-(\nu_P, t)$ are BCC-subalgebras of X if the sets are nonempty.

Suppose there exist $x, y \in X$ such that $\mu_P(x \cdot y) < \min\{\mu_P(x), \mu_P(y)\}$. Choose $t = \mu_P(x \cdot y) \in [0, 1]$. Then $\mu_P(x) > t$ and $\mu_P(y) > t$. Thus $x, y \in U^+(\mu_P, t) \neq \emptyset$. As a hypothesis, we get $U^+(\mu_P, t)$ is a BCC-subalgebra of X and so $x \cdot y \in U^+(\mu_P, t)$. Thus $\mu_P(x \cdot y) > t = \mu_P(x \cdot y)$, a contradiction. Hence, $\mu_P(x \cdot y) \geq \min\{\mu_P(x), \mu_P(y)\}$ for all $x, y \in X$.

Suppose there exist $x, y \in X$ such that $\nu_P(x \cdot y) > \max\{\nu_P(x), \nu_P(y)\}$. Choose $t = \nu_P(x \cdot y) \in [0, 1]$. Then $\nu_P(x) < t$ and $\nu_P(y) < t$. Thus $x, y \in L^-(\nu_P, t) \neq \emptyset$. As a hypothesis, we get $L^-(\nu_P, t)$ is a BCC-subalgebra of X and so $x \cdot y \in L^-(\nu_P, t)$. Thus $\nu_P(x \cdot y) < t = \nu_P(x \cdot y)$, a contradiction. Hence, $\nu_P(x \cdot y) \leq \max\{\nu_P(x), \nu_P(y)\}$ for all $x, y \in X$.

Therefore, P is a Pythagorean fuzzy BCC-subalgebra of X . □

Theorem 3.4.4 P is a Pythagorean fuzzy near BCC-filter of X if and only if $U(\mu_P, t)$ and $L(\nu_P, t)$ are, if the sets are nonempty, near BCC-filters for every $t \in [0, 1]$.

Proof. Assume $P = (\mu_P, \nu_P)$ is a Pythagorean fuzzy near BCC-filter of X . Let

$t \in [0, 1]$ be such that $U(\mu_P, t), L(\nu_P, t) \neq \emptyset$. Let $x, y \in X$. Then

$$\begin{aligned} y \in U(\mu_P, t) &\Rightarrow \mu_P(y) \geq t \\ &\Rightarrow \mu_P(x \cdot y) \geq \mu_P(y) \geq t \\ &\Rightarrow x \cdot y \in U(\mu_P, t) \end{aligned} \quad ((3.1.3))$$

and

$$\begin{aligned} x, y \in L(\nu_P, t) &\Rightarrow \nu_P(y) \leq t \\ &\Rightarrow \nu_P(x \cdot y) \leq \nu_P(y) \leq t \\ &\Rightarrow x \cdot y \in L(\nu_P, t). \end{aligned} \quad ((3.1.4))$$

Hence, $U(\mu_P, t)$ and $L(\nu_P, t)$ are near BCC-filters of X .

Conversely, assume for all $t \in [0, 1]$, $U(\mu_P, t)$ and $L(\nu_P, t)$ are near BCC-filters of X if the sets are nonempty. Let $x, y \in X$.

Choose $t = \mu_P(y) \in [0, 1]$. Then $\mu_P(y) \geq t$. Thus $y \in U(\mu_P, t) \neq \emptyset$. As a hypothesis, we get $U(\mu_P, t)$ is a near BCC-filter of X and so $x \cdot y \in U(\mu_P, t)$. Thus $\mu_P(x \cdot y) \geq t = \mu_P(y)$.

Choose $t = \nu_P(y) \in [0, 1]$. The $\nu_P(y) \leq t$. Thus $y \in L(\nu_P, t) \neq \emptyset$. As a hypothesis, we get $L(\nu_P, t)$ is a near BCC-filter of X and so $x \cdot y \in L(\nu_P, t)$. Thus $\nu_P(x \cdot y) \leq t = \nu_P(y)$.

Hence, P is a Pythagorean fuzzy near BCC-filter of X . \square

Theorem 3.4.5 P is a Pythagorean fuzzy near BCC-filter of X if and only if $U^+(\mu_P, t)$ and $L^-(\nu_P, t)$ are, if the sets are nonempty, near BCC-filters of X for every $t \in [0, 1]$.

Proof. Assume $P = (\mu_P, \nu_P)$ is a Pythagorean fuzzy near BCC-filter of X . Let

$t \in [0, 1]$ be such that $U^+(\mu_P, t), L^-(\nu_P, t) \neq \emptyset$. Let $x, y \in X$. Then

$$\begin{aligned} y \in U^+(\mu_P, t) &\Rightarrow \mu_P(y) > t \\ &\Rightarrow \mu_P(x \cdot y) \geq \mu_P(y) > t \\ &\Rightarrow x \cdot y \in U^+(\mu_P, t) \end{aligned} \quad ((3.1.3))$$

and

$$\begin{aligned} y \in L^-(\nu_P, t) &\Rightarrow \nu_P(y) < t \\ &\Rightarrow \nu_P(x \cdot y) \leq \nu_P(y) < t \\ &\Rightarrow x \cdot y \in L^-(\nu_P, t). \end{aligned} \quad ((3.1.4))$$

Hence, $U^+(\mu_P, t)$ and $L^-(\nu_P, t)$ are near BCC-filers of X .

Conversely, assume for all $t \in [0, 1]$, $U^+(\mu_P, t)$ and $L^-(\nu_P, t)$ are near BCC-filers of X if the sets are nonempty.

Suppose there exist $x, y \in X$ such that $\mu_P(x \cdot y) < \mu_P(y)$. Choose $t = \mu_P(x \cdot y) \in [0, 1]$. Then $\mu_P(y) > t$. Thus $y \in U^+(\mu_P, t) \neq \emptyset$. As a hypothesis, we get $U^+(\mu_P, t)$ is a near BCC-filter of X and so $x \cdot y \in U^+(\mu_P, t)$. Thus $\mu_P(x \cdot y) > t = \mu_P(x \cdot y)$, a contradiction. Hence, $\mu_P(x \cdot y) \geq \mu_P(y)$ for all $x, y \in X$.

Suppose there exist $x, y \in X$ such that $\nu_P(x \cdot y) > \nu_P(y)$. Choose $t = \nu_P(x \cdot y) \in [0, 1]$. Then $\nu_P(y) < t$. Thus $y \in L^-(\nu_P, t) \neq \emptyset$. As a hypothesis, we get $L^-(\nu_P, t)$ is a near BCC-filter of X and so $x \cdot y \in L^-(\nu_P, t)$. Thus $\nu_P(x \cdot y) < t = \nu_P(x \cdot y)$, a contradiction. Hence, $\nu_P(x \cdot y) \leq \nu_P(y)$ for all $x, y \in X$.

Therefore, P is a Pythagorean fuzzy near BCC-filter of X . □

Theorem 3.4.6 P is a Pythagorean fuzzy BCC-filter of X if and only if $U(\mu_P, t)$

and $L(\nu_P, t)$ are, if the sets are nonempty, BCC-filers for every $t \in [0, 1]$.

Proof. Assume $P = (\mu_P, \nu_P)$ is a Pythagorean fuzzy BCC-filter of X . Let $t \in [0, 1]$ be such that $U(\mu_P, t), L(\nu_P, t) \neq \emptyset$. Let $x, y \in X$. Then

$$\begin{aligned} x \in U(\mu_P, t) &\Rightarrow \mu_P(x) \geq t \\ &\Rightarrow \mu_P(0) \geq \mu_P(x) \geq t \\ &\Rightarrow 0 \in U(\mu_P, t), \end{aligned} \tag{3.1.5}$$

$$\begin{aligned} x \cdot y, x \in U(\mu_P, t) &\Rightarrow \mu_P(x \cdot y) \geq t, \mu_P(x) \geq t \\ &\Rightarrow \min\{\mu_P(x \cdot y), \mu_P(x)\} \geq t \\ &\Rightarrow \mu_P(y) \geq \min\{\mu_P(x \cdot y), \mu_P(x)\} \geq t \\ &\Rightarrow y \in U(\mu_P, t), \end{aligned} \tag{3.1.7}$$

$$\begin{aligned} x \in L(\nu_P, t) &\Rightarrow \nu_P(x) \leq t \\ &\Rightarrow \nu_P(0) \leq \nu_P(x) \leq t \\ &\Rightarrow 0 \in L(\nu_P, t), \end{aligned} \tag{3.1.6}$$

and

$$\begin{aligned} x \cdot y, x \in L(\nu_P, t) &\Rightarrow \nu_P(x \cdot y) \leq t, \nu_P(x) \leq t \\ &\Rightarrow \max\{\nu_P(x \cdot y), \nu_P(x)\} \leq t \\ &\Rightarrow \nu_P(y) \leq \max\{\nu_P(x \cdot y), \nu_P(x)\} \leq t \\ &\Rightarrow y \in L(\nu_P, t). \end{aligned} \tag{3.1.8}$$

Hence, $U(\mu_P, t)$ and $L(\nu_P, t)$ are BCC-filers of X .

Conversely, assume for all $t \in [0, 1]$, $U(\mu_P, t)$ and $L(\nu_P, t)$ are BCC-filters of X if the sets are nonempty. Let $x, y \in X$.

Choose $t = \mu_P(x) \in [0, 1]$. Then $\mu_P(x) \geq t$. Thus $x \in U(\mu_P, t) \neq \emptyset$. As a hypothesis, we get $U(\mu_P, t)$ is a BCC-filter of X and so $0 \in U(\mu_P, t)$. Thus $\mu_P(0) \geq t = \mu_P(x)$.

Choose $t = \min\{\mu_P(x \cdot y), \mu_P(x)\} \in [0, 1]$. Then $\mu_P(x \cdot y) \geq t$ and $\mu_P(x) \geq t$. Thus $x \cdot y, x \in U(\mu_P, t) \neq \emptyset$. As a hypothesis, we get $U(\mu_P, t)$ is a BCC-filter of X and so $y \in U(\mu_P, t)$. Thus $\mu_P(y) \geq t = \min\{\mu_P(x \cdot y), \mu_P(x)\}$.

Choose $t = \nu_P(x) \in [0, 1]$. The $\nu_P(x) \leq t$. Thus $x \in L(\nu_P, t) \neq \emptyset$. As a hypothesis, we get $L(\nu_P, t)$ is a BCC-filter of X and so $0 \in L(\nu_P, t)$. Thus $\nu_P(0) \leq t = \nu_P(x)$.

Choose $t = \max\{\nu_P(x \cdot y), \nu_P(x)\} \in [0, 1]$. Then $\nu_P(x \cdot y) \leq t$ and $\nu_P(x) \leq t$. Thus $x \cdot y, x \in L(\nu_P, t) \neq \emptyset$. As a hypothesis, we get $L(\nu_P, t)$ is a BCC-filter of X and so $y \in L(\nu_P, t)$. Thus $\nu_P(y) \leq t = \max\{\nu_P(x \cdot y), \nu_P(x)\}$.

Hence, P is a Pythagorean fuzzy BCC-filter of X . □

Theorem 3.4.7 P is a Pythagorean fuzzy BCC-filter of X if and only if $U^+(\mu_P, t)$ and $L^-(\nu_P, t)$ are, if the sets are nonempty, BCC-filters of X for every $t \in [0, 1]$.

Proof. Assume $P = (\mu_P, \nu_P)$ is a Pythagorean fuzzy BCC-filter of X . Let $t \in [0, 1]$ be such that $U^+(\mu_P, t), L^-(\nu_P, t) \neq \emptyset$. Let $x, y \in X$. Then

$$\begin{aligned} x \in U^+(\mu_P, t) &\Rightarrow \mu_P(x) > t \\ &\Rightarrow \mu_P(0) \geq \mu_P(x) > t && ((3.1.5)) \\ &\Rightarrow 0 \in U^+(\mu_P, t), \end{aligned}$$

$$\begin{aligned}
x \cdot y, x \in U^+(\mu_P, t) &\Rightarrow \mu_P(x \cdot y) > t, \mu_P(x) > t \\
&\Rightarrow \min\{\mu_P(x \cdot y), \mu_P(x)\} > t \\
&\Rightarrow \mu_P(y) \geq \min\{\mu_P(x \cdot y), \mu_P(x)\} > t \quad ((3.1.7)) \\
&\Rightarrow y \in U^+(\mu_P, t),
\end{aligned}$$

$$\begin{aligned}
x \in L^-(\nu_P, t) &\Rightarrow \nu_P(x) < t \\
&\Rightarrow \nu_P(0) \leq \nu_P(x) < t \quad ((3.1.6)) \\
&\Rightarrow 0 \in L^-(\nu_P, t),
\end{aligned}$$

and

$$\begin{aligned}
x \cdot y, x \in L^-(\nu_P, t) &\Rightarrow \nu_P(x \cdot y) < t, \nu_P(x) < t \\
&\Rightarrow \max\{\nu_P(x \cdot y), \nu_P(x)\} < t \\
&\Rightarrow \nu_P(y) \leq \max\{\nu_P(x \cdot y), \nu_P(x)\} < t \quad ((3.1.8)) \\
&\Rightarrow y \in L^-(\nu_P, t).
\end{aligned}$$

Hence, $U^+(\mu_P, t)$ and $L^-(\nu_P, t)$ are BCC-filers of X .

Conversely, assume for all $t \in [0, 1]$, $U^+(\mu_P, t)$ and $L^-(\nu_P, t)$ are BCC-filers of X if the sets are nonempty.

Suppose there exists $x \in X$ such that $\mu_P(0) < \mu_P(x)$. Choose $t = \mu_P(0) \in [0, 1]$. Then $\mu_P(x) > t$. Thus $x \in U^+(\mu_P, t) \neq \emptyset$. As a hypothesis, we get $U^+(\mu_P, t)$ is a BCC-filter of X and so $0 \in U^+(\mu_P, t)$. Thus $\mu_P(0) > t = \mu_P(0)$, a contradiction. Hence, $\mu_P(0) \geq \mu_P(x)$ for all $x \in X$.

Suppose there exist $x, y \in X$ such that $\mu_P(y) < \min\{\mu_P(x \cdot y), \mu_P(x)\}$. Choose $t = \mu_P(y) \in [0, 1]$. Then $\mu_P(x \cdot y) > t$ and $\mu_P(x) > t$. Thus $x \cdot y, x \in U^+(\mu_P, t) \neq \emptyset$. As a hypothesis, we get $U^+(\mu_P, t)$ is a BCC-filter of X and

so $y \in U^+(\mu_P, t)$. Thus $\mu_P(y) > t = \mu_P(y)$, a contradiction. Hence, $\mu_P(y) \geq \min\{\mu_P(x \cdot y), \mu_P(x)\}$ for all $x, y \in X$.

Suppose there exists $y \in X$ such that $\nu_P(0) > \nu_P(x)$. Choose $t = \nu_P(0) \in [0, 1]$. Then $\nu_P(x) < t$. Thus $x \in L^-(\nu_P, t) \neq \emptyset$. As a hypothesis, we get $L^-(\nu_P, t)$ is a BCC-filter of X and so $0 \in L^-(\nu_P, t)$. Thus $\nu_P(0) < t = \nu_P(0)$, a contradiction. Hence, $\nu_P(0) \leq \nu_P(x)$ for all $x, y \in X$.

Suppose there exist $x, y \in X$ such that $\nu_P(y) > \max\{\nu_P(x \cdot y), \nu_P(x)\}$. Choose $t = \nu_P(y) \in [0, 1]$. Then $\nu_P(x \cdot y) < t$ and $\nu_P(x) < t$. Thus $x \cdot y, x \in L^-(\nu_P, t) \neq \emptyset$. As a hypothesis, we get $L^-(\nu_P, t)$ is a BCC-filter of X and so $y \in L^-(\nu_P, t)$. Thus $\nu_P(y) < t = \nu_P(y)$, a contradiction. Hence, $\nu_P(y) \leq \max\{\nu_P(x \cdot y), \nu_P(x)\}$ for all $x, y \in X$.

Therefore, P is a Pythagorean fuzzy BCC-filter of X . □

Theorem 3.4.8 P is a Pythagorean fuzzy implicative BCC-filters of X if and only if $U(\mu_P, t)$ and $L(\nu_P, t)$ are, if the sets are nonempty, implicative BCC-filters for every $t \in [0, 1]$.

Proof. Assume $P = (\mu_P, \nu_P)$ is a Pythagorean fuzzy implicative BCC-filters of X . Let $t \in [0, 1]$ be such that $U(\mu_P, t), L(\nu_P, t) \neq \emptyset$. Let $x, y \in X$. Then

$$\begin{aligned} x \in U(\mu_P, t) &\Rightarrow \mu_P(x) \geq t \\ &\Rightarrow \mu_P(0) \geq \mu_P(x) \geq t \\ &\Rightarrow 0 \in U(\mu_P, t), \end{aligned} \tag{3.1.5}$$

$$\begin{aligned} x \cdot (y \cdot z), x \cdot y &\in U(\mu_P, t) \\ &\Rightarrow \mu_P(x \cdot (y \cdot z)) \geq t, \mu_P(x \cdot y) \geq t \\ &\Rightarrow \min\{\mu_P(x \cdot (y \cdot z)), \mu_P(x \cdot y)\} \geq t \end{aligned}$$

$$\Rightarrow \mu_{\mathbb{P}}(x \cdot z) \geq \min\{\mu_{\mathbb{P}}(x \cdot (y \cdot z)), \mu_{\mathbb{P}}(x \cdot y)\} \geq t \quad ((3.1.9))$$

$$\Rightarrow x \cdot z \in U(\mu_{\mathbb{P}}, t),$$

$$\begin{aligned} x \in L(\nu_{\mathbb{P}}, t) &\Rightarrow \nu_{\mathbb{P}}(x) \leq t \\ &\Rightarrow \nu_{\mathbb{P}}(0) \leq \nu_{\mathbb{P}}(x) \leq t \\ &\Rightarrow 0 \in L(\nu_{\mathbb{P}}, t), \end{aligned} \quad ((3.1.6))$$

and

$$\begin{aligned} x \cdot (y \cdot z), x \cdot y \in L(\nu_{\mathbb{P}}, t) \\ &\Rightarrow \nu_{\mathbb{P}}(x \cdot (y \cdot z)) \leq t, \nu_{\mathbb{P}}(x \cdot y) \leq t \\ &\Rightarrow \max\{\mu_{\mathbb{P}}(x \cdot (y \cdot z)), \nu_{\mathbb{P}}(x \cdot y)\} \leq t \\ &\Rightarrow \nu_{\mathbb{P}}(x \cdot z) \leq \max\{\nu_{\mathbb{P}}(x \cdot (y \cdot z)), \nu_{\mathbb{P}}(x \cdot y)\} \leq t \quad ((3.1.10)) \\ &\Rightarrow x \cdot z \in L(\nu_{\mathbb{P}}, t). \end{aligned}$$

Hence, $U(\mu_{\mathbb{P}}, t)$ and $L(\nu_{\mathbb{P}}, t)$ are implicative BCC-filters of X .

Conversely, assume for all $t \in [0, 1]$, $U(\mu_{\mathbb{P}}, t)$ and $L(\nu_{\mathbb{P}}, t)$ are implicative BCC-filters of X if the sets are nonempty. Let $x, y \in X$.

Choose $t = \mu_{\mathbb{P}}(x) \in [0, 1]$. Then $\mu_{\mathbb{P}}(x) \geq t$. Thus $x \in U(\mu_{\mathbb{P}}, t) \neq \emptyset$. As a hypothesis, we get $U(\mu_{\mathbb{P}}, t)$ is an implicative BCC-filter of X and so $0 \in U(\mu_{\mathbb{P}}, t)$. Thus $\mu_{\mathbb{P}}(0) \geq t = \mu_{\mathbb{P}}(x)$.

Choose $t = \min\{\mu_{\mathbb{P}}(x \cdot (y \cdot z)), \mu_{\mathbb{P}}(x \cdot y)\} \in [0, 1]$. Then $\mu_{\mathbb{P}}(x \cdot (y \cdot z)) \geq t$ and $\mu_{\mathbb{P}}(x \cdot y) \geq t$. Thus $x \cdot (y \cdot z), x \cdot y \in U(\mu_{\mathbb{P}}, t) \neq \emptyset$. As a hypothesis, we get $U(\mu_{\mathbb{P}}, t)$ is an implicative BCC-filter of X and so $x \cdot z \in U(\mu_{\mathbb{P}}, t)$. Thus $\mu_{\mathbb{P}}(x \cdot z) \geq t = \min\{\mu_{\mathbb{P}}(x \cdot (y \cdot z)), \mu_{\mathbb{P}}(x \cdot y)\}$.

Choose $t = \nu_P(x) \in [0, 1]$. The $\nu_P(x) \leq t$. Thus $x \in L(\nu_P, t) \neq \emptyset$. As a hypothesis, we get $L(\nu_P, t)$ is an implicative BCC-filter of X and so $0 \in U(\nu_P, t)$. Thus $\nu_P(0) \leq t = \nu_P(x)$.

Choose $t = \max\{\nu_P(x \cdot (y \cdot z)), \nu_P(x \cdot y)\} \in [0, 1]$. Then $\nu_P(x \cdot (y \cdot z)) \leq t$ and $\nu_P(x \cdot y) \leq t$. Thus $x \cdot (y \cdot z), x \cdot y \in L(\mu_P, t) \neq \emptyset$. As a hypothesis, we get $L(\mu_P, t)$ is an implicative BCC-filter of X and so $x \cdot z \in L(\mu_P, t)$. Thus $\nu_P(x \cdot z) \leq t = \max\{\nu_P(x \cdot (y \cdot z)), \nu_P(x \cdot y)\}$.

Hence, P is a Pythagorean fuzzy implicative BCC-filter of X . \square

Theorem 3.4.9 P is a Pythagorean fuzzy implicative BCC-filter of X if and only if $U^+(\mu_P, t)$ and $L^-(\nu_P, t)$ are, if the sets are nonempty, implicative BCC-filters of X for every $t \in [0, 1]$.

Proof. Assume $P = (\mu_P, \nu_P)$ is a Pythagorean fuzzy implicative BCC-filter of X . Let $t \in [0, 1]$ be such that $U^+(\mu_P, t), L^-(\nu_P, t) \neq \emptyset$. Let $x, y \in X$. Then

$$\begin{aligned} x \in U^+(\mu_P, t) &\Rightarrow \mu_P(x) > t \\ &\Rightarrow \mu_P(0) \geq \mu_P(x) > t \\ &\Rightarrow 0 \in U^+(\mu_P, t), \end{aligned} \tag{3.1.5}$$

$$\begin{aligned} x \cdot (y \cdot z), x \cdot y \in U^+(\mu_P, t) & \\ \Rightarrow \mu_P(x \cdot (y \cdot z)) > t, \mu_P(x \cdot y) > t & \\ \Rightarrow \min\{\mu_P(x \cdot (y \cdot z)), \mu_P(x \cdot y)\} > t & \\ \Rightarrow \mu_P(x \cdot z) \geq \min\{\mu_P(x \cdot (y \cdot z)), \mu_P(x \cdot y)\} > t & \tag{3.1.9} \\ \Rightarrow x \cdot z \in U^+(\mu_P, t), & \end{aligned}$$

$$\begin{aligned}
x \in L^-(\nu_P, t) &\Rightarrow \nu_P(x) < t \\
&\Rightarrow \nu_P(0) \leq \nu_P(x) < t && ((3.1.6)) \\
&\Rightarrow 0 \in L^-(\nu_P, t),
\end{aligned}$$

and

$$\begin{aligned}
x \cdot (y \cdot z), x \cdot y \in L^-(\nu_P, t) \\
&\Rightarrow \nu_P(x \cdot (y \cdot z)) < t, \nu_P(x \cdot y) < t \\
&\Rightarrow \max\{\nu_P(x \cdot (y \cdot z)), \nu_P(x \cdot y)\} < t \\
&\Rightarrow \nu_P(x \cdot z) \leq \max\{\nu_P(x \cdot (y \cdot z)), \nu_P(x \cdot y)\} < t && ((3.1.10)) \\
&\Rightarrow x \cdot z \in L^-(\nu_P, t).
\end{aligned}$$

Hence, $U^+(\mu_P, t)$ and $L^-(\nu_P, t)$ are implicative BCC-filters of X .

Conversely, assume for all $t \in [0, 1]$, $U^+(\mu_P, t)$ and $L^-(\nu_P, t)$ are implicative BCC-filters of X if the sets are nonempty.

Suppose there exists $x \in X$ such that $\mu_P(0) < \mu_P(x)$. Choose $t = \mu_P(0) \in [0, 1]$. Then $\mu_P(x) > t$. Thus $x \in U^+(\mu_P, t) \neq \emptyset$. As a hypothesis, we get $U^+(\mu_P, t)$ is an implicative BCC-filter of X and so $0 \in U^+(\mu_P, t)$. Thus $\mu_P(0) > t = \mu_P(0)$, a contradiction. Hence, $\mu_P(0) \geq \mu_P(x)$ for all $x \in X$.

Suppose there exist $x, y \in X$ such that $\mu_P(x \cdot z) < \min\{\mu_P(x \cdot (y \cdot z)), \mu_P(x \cdot y)\}$. Choose $t = \mu_P(x \cdot z) \in [0, 1]$. Then $\mu_P(x \cdot (y \cdot z)) > t$ and $\mu_P(x \cdot y) > t$. Thus $x \cdot (y \cdot z), x \cdot y \in U^+(\mu_P, t) \neq \emptyset$. As a hypothesis, we get $U^+(\mu_P, t)$ is an implicative BCC-filter of X and so $x \cdot z \in U^+(\mu_P, t)$. Thus $\mu_P(x \cdot z) > t = \mu_P(x \cdot z)$, a contradiction. Hence, $\mu_P(x \cdot z) \geq \min\{\mu_P(x \cdot (y \cdot z)), \mu_P(x \cdot y)\}$ for all $x, y \in X$.

Suppose there exists $y \in X$ such that $\nu_P(0) > \nu_P(x)$. Choose $t = \nu_P(0) \in [0, 1]$. Then $\nu_P(x) < t$. Thus $x \in L^-(\nu_P, t) \neq \emptyset$. As a hypothesis, we get $L^-(\nu_P, t)$

is an implicative BCC-filter of X and so $0 \in L^-(\nu_P, t)$. Thus $\nu_P(0) < t = \nu_P(0)$, a contradiction. Hence, $\nu_P(0) \leq \nu_P(x)$ for all $x, y \in X$.

Suppose there exist $x, y \in X$ such that $\nu_P(x \cdot z) > \max\{\nu_P(x \cdot (y \cdot z)), \nu_P(x \cdot y)\}$. Choose $t = \nu_P(x \cdot z) \in [0, 1]$. Then $\nu_P(x \cdot (y \cdot z)) < t$ and $\nu_P(x \cdot y) < t$. Thus $x \cdot (y \cdot z), x \cdot y \in L^-(\nu_P, t) \neq \emptyset$. As a hypothesis, we get $L^-(\nu_P, t)$ is an implicative BCC-filter of X and so $x \cdot z \in L^-(\nu_P, t)$. Thus $\nu_P(x \cdot z) < t = \nu_P(x \cdot z)$, a contradiction. Hence, $\nu_P(x \cdot z) \leq \max\{\nu_P(x \cdot (y \cdot z)), \nu_P(x \cdot y)\}$ for all $x, y \in X$.

Therefore, P is a Pythagorean fuzzy implicative BCC-filter of X . \square

Theorem 3.4.10 P is a Pythagorean fuzzy comparative BCC-filter of X if and only if $U(\mu_P, t)$ and $L(\nu_P, t)$ are, if the sets are nonempty, comparative BCC-filters for every $t \in [0, 1]$.

Proof. Assume $P = (\mu_P, \nu_P)$ is a Pythagorean fuzzy comparative BCC-filters of X . Let $t \in [0, 1]$ be such that $U(\mu_P, t), L(\nu_P, t) \neq \emptyset$. Let $x, y \in X$. Then

$$\begin{aligned} x \in U(\mu_P, t) &\Rightarrow \mu_P(x) \geq t \\ &\Rightarrow \mu_P(0) \geq \mu_P(x) \geq t \\ &\Rightarrow 0 \in U(\mu_P, t), \end{aligned} \tag{3.1.5}$$

$$\begin{aligned} x \cdot ((y \cdot z) \cdot y), x \in U(\mu_P, t) \\ &\Rightarrow \mu_P(x \cdot ((y \cdot z) \cdot y)) \geq t, \mu_P(x) \geq t \\ &\Rightarrow \min\{\mu_P(x \cdot ((y \cdot z) \cdot y)), \mu_P(x)\} \geq t \\ &\Rightarrow \mu_P(y) \geq \min\{\mu_P(x \cdot ((y \cdot z) \cdot y)), \mu_P(x)\} \geq t \tag{3.1.11} \\ &\Rightarrow y \in U(\mu_P, t), \end{aligned}$$

$$\begin{aligned}
x \in L(\nu_P, t) &\Rightarrow \nu_P(x) \leq t \\
&\Rightarrow \nu_P(0) \leq \nu_P(x) \leq t && ((3.1.6)) \\
&\Rightarrow 0 \in L(\nu_P, t),
\end{aligned}$$

and

$$\begin{aligned}
x \cdot ((y \cdot z) \cdot y), x \in L(\nu_P, t) \\
&\Rightarrow \nu_P(x \cdot ((y \cdot z) \cdot y)) \leq t, \nu_P(x) \leq t \\
&\Rightarrow \max\{\mu_P(x \cdot ((y \cdot z) \cdot y)), \nu_P(x)\} \leq t \\
&\Rightarrow \nu_P(y) \leq \max\{\nu_P(x \cdot ((y \cdot z) \cdot y)), \nu_P(x)\} \leq t && ((3.1.12)) \\
&\Rightarrow y \in L(\nu_P, t).
\end{aligned}$$

Hence, $U(\mu_P, t)$ and $L(\nu_P, t)$ are comparative BCC-filters of X .

Conversely, assume for all $t \in [0, 1]$, $U(\mu_P, t)$ and $L(\nu_P, t)$ are comparative BCC-filters of X if the sets are nonempty. Let $x, y \in X$.

Choose $t = \mu_P(x) \in [0, 1]$. Then $\mu_P(x) \geq t$. Thus $x \in U(\mu_P, t) \neq \emptyset$. As a hypothesis, we get $U(\mu_P, t)$ is a comparative BCC-filter of X and so $0 \in U(\mu_P, t)$. Thus $\mu_P(0) \geq t = \mu_P(x)$.

Choose $t = \min\{\mu_P(x \cdot ((y \cdot z) \cdot y)), \mu_P(x)\} \in [0, 1]$. Then $\mu_P(x \cdot ((y \cdot z) \cdot y)) \geq t$ and $\mu_P(x) \geq t$. Thus $x \cdot ((y \cdot z) \cdot y), x \in U(\mu_P, t) \neq \emptyset$. As a hypothesis, we get $U(\mu_P, t)$ is a comparative BCC-filter of X and so $y \in U(\mu_P, t)$. Thus $\mu_P(y) \geq t = \min\{\mu_P(x \cdot ((y \cdot z) \cdot y)), \mu_P(x)\}$.

Choose $t = \nu_P(x) \in [0, 1]$. The $\nu_P(x) \leq t$. Thus $x \in L(\nu_P, t) \neq \emptyset$. As a hypothesis, we get $L(\nu_P, t)$ is a comparative BCC-filter of X and so $0 \in U(\nu_P, t)$. Thus $\nu_P(0) \leq t = \nu_P(x)$.

Choose $t = \max\{\nu_P(x \cdot ((y \cdot z) \cdot y)), \nu_P(x)\} \in [0, 1]$. Then $\nu_P(x \cdot ((y \cdot z) \cdot y)) \leq$

t and $\nu_P(x) \leq t$. Thus $x \cdot ((y \cdot z) \cdot y), x \in L(\mu_P, t) \neq \emptyset$. As a hypothesis, we get $L(\mu_P, t)$ is a comparative BCC-filter of X and so $y \in L(\mu_P, t)$. Thus $\nu_P(y) \leq t = \max\{\nu_P(x \cdot ((y \cdot z) \cdot y)), \nu_P(x)\}$.

Hence, P is a Pythagorean fuzzy comparative BCC-filter of X . \square

Theorem 3.4.11 P is a Pythagorean fuzzy comparative BCC-filter of X if and only if $U^+(\mu_P, t)$ and $L^-(\nu_P, t)$ are, if the sets are nonempty, comparative BCC-filters of X for every $t \in [0, 1]$.

Proof. Assume $P = (\mu_P, \nu_P)$ is a Pythagorean fuzzy comparative BCC-filter of X . Let $t \in [0, 1]$ be such that $U^+(\mu_P, t), L^-(\nu_P, t) \neq \emptyset$. Let $x, y \in X$. Then

$$\begin{aligned} x \in U^+(\mu_P, t) &\Rightarrow \mu_P(x) > t \\ &\Rightarrow \mu_P(0) \geq \mu_P(x) > t \\ &\Rightarrow 0 \in U^+(\mu_P, t), \end{aligned} \tag{3.1.5}$$

$$\begin{aligned} x \cdot ((y \cdot z) \cdot y), x \in U^+(\mu_P, t) & \\ \Rightarrow \mu_P(x \cdot ((y \cdot z) \cdot y)) > t, \mu_P(x) > t & \\ \Rightarrow \min\{\mu_P(x \cdot ((y \cdot z) \cdot y)), \mu_P(x)\} > t & \\ \Rightarrow \mu_P(y) \geq \min\{\mu_P(x \cdot ((y \cdot z) \cdot y)), \mu_P(x)\} > t & \tag{3.1.11} \\ \Rightarrow y \in U^+(\mu_P, t), & \end{aligned}$$

$$\begin{aligned} x \in L^-(\nu_P, t) &\Rightarrow \nu_P(x) < t \\ &\Rightarrow \nu_P(0) \leq \nu_P(x) < t \\ &\Rightarrow 0 \in L^-(\nu_P, t), \end{aligned} \tag{3.1.6}$$

and

$$\begin{aligned}
& x \cdot ((y \cdot z) \cdot y), x \in L^-(\nu_P, t) \\
& \Rightarrow \nu_P(x \cdot ((y \cdot z) \cdot y)) < t, \nu_P(x) < t \\
& \Rightarrow \max\{\nu_P(x \cdot ((y \cdot z) \cdot y)), \nu_P(x)\} < t \\
& \Rightarrow \nu_P(y) \leq \max\{\nu_P(x \cdot ((y \cdot z) \cdot y)), \nu_P(x)\} < t \quad ((3.1.12)) \\
& \Rightarrow y \in L^-(\nu_P, t).
\end{aligned}$$

Hence, $U^+(\mu_P, t)$ and $L^-(\nu_P, t)$ are comparative BCC-filters of X .

Conversely, assume for all $t \in [0, 1]$, $U^+(\mu_P, t)$ and $L^-(\nu_P, t)$ are comparative BCC-filters of X if the sets are nonempty.

Suppose there exists $x \in X$ such that $\mu_P(0) < \mu_P(x)$. Choose $t = \mu_P(0) \in [0, 1]$. Then $\mu_P(x) > t$. Thus $x \in U^+(\mu_P, t) \neq \emptyset$. As a hypothesis, we get $U^+(\mu_P, t)$ is a comparative BCC-filter of X and so $0 \in U^+(\mu_P, t)$. Thus $\mu_P(0) > t = \mu_P(0)$, a contradiction. Hence, $\mu_P(0) \geq \mu_P(x)$ for all $x \in X$.

Suppose there exist $x, y \in X$ such that $\mu_P(y) < \min\{\mu_P(x \cdot ((y \cdot z) \cdot y)), \mu_P(x)\}$. Choose $t = \mu_P(y) \in [0, 1]$. Then $\mu_P(x \cdot ((y \cdot z) \cdot y)) > t$ and $\mu_P(x) > t$. Thus $x \cdot ((y \cdot z) \cdot y), x \in U^+(\mu_P, t) \neq \emptyset$. As a hypothesis, we get $U^+(\mu_P, t)$ is a comparative BCC-filter of X and so $y \in U^+(\mu_P, t)$. Thus $\mu_P(y) > t = \mu_P(y)$, a contradiction. Hence, $\mu_P(y) \geq \min\{\mu_P(x \cdot ((y \cdot z) \cdot y)), \mu_P(x)\}$ for all $x, y \in X$.

Suppose there exists $y \in X$ such that $\nu_P(0) > \nu_P(x)$. Choose $t = \nu_P(0) \in [0, 1]$. Then $\nu_P(x) < t$. Thus $x \in L^-(\nu_P, t) \neq \emptyset$. As a hypothesis, we get $L^-(\nu_P, t)$ is a comparative BCC-filter of X and so $0 \in L^-(\nu_P, t)$. Thus $\nu_P(0) < t = \nu_P(0)$, a contradiction. Hence, $\nu_P(0) \leq \nu_P(x)$ for all $x, y \in X$.

Suppose there exist $x, y \in X$ such that $\nu_P(y) > \max\{\nu_P(x \cdot ((y \cdot z) \cdot y)), \nu_P(x)\}$. Choose $t = \nu_P(y) \in [0, 1]$. Then $\nu_P(x \cdot ((y \cdot z) \cdot y)) < t$ and $\nu_P(x) < t$.

Thus $x \cdot ((y \cdot z) \cdot y), x \in L^-(\nu_P, t) \neq \emptyset$. As a hypothesis, we get $L^-(\nu_P, t)$ is a comparative BCC-filter of X and so $y \in L^-(\nu_P, t)$. Thus $\nu_P(y) < t = \nu_P(y)$, a contradiction. Hence, $\nu_P(y) \leq \max\{\nu_P(x \cdot ((y \cdot z) \cdot y)), \nu_P(x)\}$ for all $x, y \in X$.

Therefore, P is a Pythagorean fuzzy comparative BCC-filter of X . \square

Theorem 3.4.12 P is a Pythagorean fuzzy shift BCC-filter of X if and only if $U(\mu_P, t)$ and $L(\nu_P, t)$ are, if the sets are nonempty, shift BCC-filters for every $t \in [0, 1]$.

Proof. Assume $P = (\mu_P, \nu_P)$ is a Pythagorean fuzzy shift BCC-filter of X . Let $t \in [0, 1]$ be such that $U(\mu_P, t), L(\nu_P, t) \neq \emptyset$. Let $x, y, z \in X$. Then

$$\begin{aligned} x \in U(\mu_P, t) &\Rightarrow \mu_P(x) \geq t \\ &\Rightarrow \mu_P(0) \geq \mu_P(x) \geq t \\ &\Rightarrow 0 \in U(\mu_P, t), \end{aligned} \tag{3.1.5}$$

$$\begin{aligned} x \cdot (y \cdot z), x \in U(\mu_P, t) & \\ \Rightarrow \mu_P(x \cdot (y \cdot z)) \geq t, \mu_P(x) \geq t & \\ \Rightarrow \min\{\mu_P(x \cdot (y \cdot z)), \mu_P(x)\} \geq t & \\ \Rightarrow \mu_P(((z \cdot y) \cdot y) \cdot z) \geq \min\{\mu_P(x \cdot (y \cdot z)), \mu_P(x)\} \geq t & \tag{3.1.13} \\ \Rightarrow ((z \cdot y) \cdot y) \cdot z \in U(\mu_P, t), & \end{aligned}$$

$$\begin{aligned} x \in L(\nu_P, t) &\Rightarrow \nu_P(x) \leq t \\ &\Rightarrow \nu_P(0) \leq \nu_P(x) \leq t \\ &\Rightarrow 0 \in L(\nu_P, t), \end{aligned} \tag{3.1.6}$$

and

$$\begin{aligned}
& x \cdot (y \cdot z), x \in L(\nu_P, t) \\
& \Rightarrow \nu_P(x \cdot (y \cdot z)) \leq t, \nu_P(x) \leq t \\
& \Rightarrow \max\{\mu_P(x \cdot (y \cdot z)), \nu_P(x)\} \leq t \\
& \Rightarrow \nu_P(((z \cdot y) \cdot y) \cdot z) \leq \max\{\nu_P(x \cdot (y \cdot z)), \nu_P(x)\} \leq t \quad ((3.1.14)) \\
& \Rightarrow ((z \cdot y) \cdot y) \cdot z \in L(\nu_P, t).
\end{aligned}$$

Hence, $U(\mu_P, t)$ and $L(\nu_P, t)$ are shift BCC-filters of X .

Conversely, assume for all $t \in [0, 1]$, $U(\mu_P, t)$ and $L(\nu_P, t)$ are shift BCC-filters of X if the sets are nonempty. Let $x, y, z \in X$.

Choose $t = \mu_P(x) \in [0, 1]$. Then $\mu_P(x) \geq t$. Thus $x \in U(\mu_P, t) \neq \emptyset$. As a hypothesis, we get $U(\mu_P, t)$ is a shift BCC-filter of X and so $0 \in U(\mu_P, t)$. Thus $\mu_P(0) \geq t = \mu_P(x)$.

Choose $t = \min\{\mu_P(x \cdot (y \cdot z)), \mu_P(x)\} \in [0, 1]$. Then $\mu_P(x \cdot (y \cdot z)) \geq t$ and $\mu_P(x) \geq t$. Thus $x \cdot (y \cdot z), x \in U(\mu_P, t) \neq \emptyset$. As a hypothesis, we get $U(\mu_P, t)$ is a shift BCC-filter of X and so $((z \cdot y) \cdot y) \cdot z \in U(\mu_P, t)$. Thus $\mu_P(((z \cdot y) \cdot y) \cdot z) \geq t = \min\{\mu_P(x \cdot (y \cdot z)), \mu_P(x)\}$.

Choose $t = \nu_P(x) \in [0, 1]$. The $\nu_P(x) \leq t$. Thus $x \in L(\nu_P, t) \neq \emptyset$. As a hypothesis, we get $L(\nu_P, t)$ is a shift BCC-filter of X and so $0 \in U(\nu_P, t)$. Thus $\nu_P(0) \leq t = \nu_P(x)$.

Choose $t = \max\{\nu_P(x \cdot (y \cdot z)), \nu_P(x)\} \in [0, 1]$. Then $\nu_P(x \cdot (y \cdot z)) \leq t$ and $\nu_P(x) \leq t$. Thus $x \cdot (y \cdot z), x \in L(\nu_P, t) \neq \emptyset$. As a hypothesis, we get $L(\nu_P, t)$ is a shift BCC-filter of X and so $((z \cdot y) \cdot y) \cdot z \in L(\nu_P, t)$. Thus $\nu_P(((z \cdot y) \cdot y) \cdot z) \geq t = \max\{\nu_P(x \cdot (y \cdot z)), \nu_P(x)\}$.

Hence, P is a Pythagorean fuzzy shift BCC-filter of X . \square

Theorem 3.4.13 P is a Pythagorean fuzzy shift BCC-filter of X if and only if $U^+(\mu_P, t)$ and $L^-(\nu_P, t)$ are, if the sets are nonempty, shift BCC-filters of X for every $t \in [0, 1]$.

Proof. Assume $P = (\mu_P, \nu_P)$ is a Pythagorean fuzzy shift BCC-filter of X . Let $t \in [0, 1]$ be such that $U^+(\mu_P, t), L^-(\nu_P, t) \neq \emptyset$. Let $x, y, z \in X$. Then

$$\begin{aligned} x \in U^+(\mu_P, t) &\Rightarrow \mu_P(x) > t \\ &\Rightarrow \mu_P(0) \geq \mu_P(x) > t \\ &\Rightarrow 0 \in U^+(\mu_P, t), \end{aligned} \quad ((3.1.5))$$

$$\begin{aligned} x \cdot (y \cdot z), x \in U^+(\mu_P, t) \\ &\Rightarrow \mu_P(x \cdot (y \cdot z)) > t, \mu_P(x) > t \\ &\Rightarrow \min\{\mu_P(x \cdot (y \cdot z)), \mu_P(x)\} > t \\ &\Rightarrow \mu_P(((z \cdot y) \cdot y) \cdot z) \geq \min\{\mu_P(x \cdot (y \cdot z)), \mu_P(x)\} > t \\ &\Rightarrow ((z \cdot y) \cdot y) \cdot z \in U^+(\mu_P, t), \end{aligned} \quad ((3.1.13))$$

$$\begin{aligned} x \in L^-(\nu_P, t) &\Rightarrow \nu_P(x) < t \\ &\Rightarrow \nu_P(0) \leq \nu_P(x) < t \\ &\Rightarrow 0 \in L^-(\nu_P, t), \end{aligned} \quad ((3.1.6))$$

and

$$\begin{aligned} x \cdot (y \cdot z), x \in L^-(\nu_P, t) \\ &\Rightarrow \nu_P(x \cdot (y \cdot z)) < t, \nu_P(x) < t \end{aligned}$$

$$\begin{aligned}
&\Rightarrow \max\{\nu_P(x \cdot (y \cdot z)), \nu_P(x)\} < t \\
&\Rightarrow \nu_P(((z \cdot y) \cdot y) \cdot z) \leq \max\{\nu_P(x \cdot (y \cdot z)), \nu_P(x)\} < t \quad ((3.1.14)) \\
&\Rightarrow ((z \cdot y) \cdot y) \cdot z \in L^-(\nu_P, t).
\end{aligned}$$

Hence, $U^+(\mu_P, t)$ and $L^-(\nu_P, t)$ are shift BCC-filters of X .

Conversely, assume for all $t \in [0, 1]$, $U^+(\mu_P, t)$ and $L^-(\nu_P, t)$ are shift BCC-filters of X if the sets are nonempty.

Suppose there exists $x \in X$ such that $\mu_P(0) < \mu_P(x)$. Choose $t = \mu_P(0) \in [0, 1]$. Then $\mu_P(x) > t$. Thus $x \in U^+(\mu_P, t) \neq \emptyset$. As a hypothesis, we get $U^+(\mu_P, t)$ is a shift BCC-filter of X and so $0 \in U^+(\mu_P, t)$. Thus $\mu_P(0) > t = \mu_P(0)$, a contradiction. Hence, $\mu_P(0) \geq \mu_P(x)$ for all $x \in X$.

Suppose there exist $x, y, z \in X$ such that $\mu_P(((z \cdot y) \cdot y) \cdot z) < \min\{\mu_P(x \cdot (y \cdot z)), \mu_P(x)\}$. Choose $t = \mu_P(((z \cdot y) \cdot y) \cdot z) \in [0, 1]$. Then $\mu_P(x \cdot (y \cdot z)) > t$ and $\mu_P(x) > t$. Thus $x \cdot (y \cdot z), x \in U^+(\mu_P, t) \neq \emptyset$. As a hypothesis, we get $U^+(\mu_P, t)$ is a shift BCC-filter of X and so $((z \cdot y) \cdot y) \cdot z \in U^+(\mu_P, t)$. Thus $\mu_P(((z \cdot y) \cdot y) \cdot z) > t = \mu_P(((z \cdot y) \cdot y) \cdot z)$, a contradiction. Hence, $\mu_P(((z \cdot y) \cdot y) \cdot z) \geq \min\{\mu_P(x \cdot (y \cdot z)), \mu_P(x)\}$ for all $x, y \in X$.

Suppose there exists $y \in X$ such that $\nu_P(0) > \nu_P(x)$. Choose $t = \nu_P(0) \in [0, 1]$. Then $\nu_P(x) < t$. Thus $x \in L^-(\nu_P, t) \neq \emptyset$. As a hypothesis, we get $L^-(\nu_P, t)$ is a shift BCC-filter of X and so $0 \in L^-(\nu_P, t)$. Thus $\nu_P(0) < t = \nu_P(0)$, a contradiction. Hence, $\nu_P(0) \leq \nu_P(x)$ for all $x, y \in X$.

Suppose there exist $x, y, z \in X$ such that $\nu_P(((z \cdot y) \cdot y) \cdot z) > \max\{\nu_P(x \cdot (y \cdot z)), \nu_P(x)\}$. Choose $t = \nu_P(((z \cdot y) \cdot y) \cdot z) \in [0, 1]$. Then $\nu_P(x \cdot (y \cdot z)) < t$ and $\nu_P(x) < t$. Thus $x \cdot (y \cdot z), x \in L^-(\nu_P, t) \neq \emptyset$. As a hypothesis, we get $L^-(\nu_P, t)$ is a shift BCC-filter of X and so $((z \cdot y) \cdot y) \cdot z \in L^-(\nu_P, t)$. Thus $\nu_P(((z \cdot y) \cdot y) \cdot z) < t = \nu_P(((z \cdot y) \cdot y) \cdot z)$, a contradiction. Hence, $\nu_P(((z \cdot y) \cdot y) \cdot z) \leq \max\{\nu_P(x \cdot (y \cdot z)), \nu_P(x)\}$ for all $x, y \in X$.

$\max\{\nu_P(x \cdot (y \cdot z)), \nu_P(x)\}$ for all $x, y \in X$.

Therefore, P is a Pythagorean fuzzy shift BCC-filter of X . \square

Theorem 3.4.14 P is a Pythagorean fuzzy BCC-ideal of X if and only if $U(\mu_P, t)$ and $L(\nu_P, t)$ are, if the sets are nonempty, BCC-ideals for every $t \in [0, 1]$.

Proof. Assume $P = (\mu_P, \nu_P)$ is a Pythagorean fuzzy BCC-ideal of X . Let $t \in [0, 1]$ be such that $U(\mu_P, t), L(\nu_P, t) \neq \emptyset$. Let $x, y, z \in X$. Then

$$\begin{aligned} x \in U(\mu_P, t) &\Rightarrow \mu_P(x) \geq t \\ &\Rightarrow \mu_P(0) \geq \mu_P(x) \geq t \\ &\Rightarrow 0 \in U(\mu_P, t), \end{aligned} \quad ((3.1.5))$$

$$\begin{aligned} x \cdot (y \cdot z), y \in U(\mu_P, t) &\Rightarrow \mu_P(x \cdot (y \cdot z)) \geq t, \mu_P(y) \geq t \\ &\Rightarrow \min\{\mu_P(x \cdot (y \cdot z)), \mu_P(y)\} \geq t \\ &\Rightarrow \mu_P(x \cdot z) \geq \min\{\mu_P(x \cdot (y \cdot z)), \mu_P(y)\} \geq t \\ &\Rightarrow x \cdot z \in U(\mu_P, t), \end{aligned} \quad ((3.1.15))$$

$$\begin{aligned} x \in L(\nu_P, t) &\Rightarrow \nu_P(x) \leq t \\ &\Rightarrow \nu_P(0) \leq \nu_P(x) \leq t \\ &\Rightarrow 0 \in L(\nu_P, t), \end{aligned} \quad ((3.1.6))$$

and

$$\begin{aligned} x \cdot (y \cdot z), y \in L(\nu_P, t) &\Rightarrow \nu_P(x \cdot (y \cdot z)) \leq t, \nu_P(y) \leq t \\ &\Rightarrow \max\{\nu_P(x \cdot (y \cdot z)), \nu_P(y)\} \leq t \\ &\Rightarrow \nu_P(x \cdot z) \leq \max\{\nu_P(x \cdot (y \cdot z)), \nu_P(y)\} \leq t \end{aligned} \quad ((3.1.16))$$

$$\Rightarrow x \cdot z \in L(\nu_P, t).$$

Hence, $U(\mu_P, t)$ and $L(\nu_P, t)$ are BCC-ideals of X .

Conversely, assume for all $t \in [0, 1]$, $U(\mu_P, t)$ and $L(\nu_P, t)$ are BCC-ideals of X if the sets are nonempty. Let $x, y, z \in X$.

Choose $t = \mu_P(x) \in [0, 1]$. Then $\mu_P(x) \geq t$. Thus $x \in U(\mu_P, t) \neq \emptyset$. As a hypothesis, we get $U(\mu_P, t)$ is a BCC-ideal of X and so $0 \in U(\mu_P, t)$. Thus $\mu_P(0) \geq t = \mu_P(x)$.

Choose $t = \min\{\mu_P(x \cdot (y \cdot z)), \mu_P(y)\} \in [0, 1]$. Then $\mu_P(x \cdot (y \cdot z)) \geq t$ and $\mu_P(y) \geq t$. Thus $x \cdot (y \cdot z), y \in U(\mu_P, t) \neq \emptyset$. As a hypothesis, we get $U(\mu_P, t)$ is a BCC-ideal of X and so $x \cdot z \in U(\mu_P, t)$. Thus $\mu_P(x \cdot z) \geq t = \min\{\mu_P(x \cdot (y \cdot z)), \mu_P(y)\}$.

Choose $t = \nu_P(x) \in [0, 1]$. The $\nu_P(x) \leq t$. Thus $x \in L(\nu_P, t) \neq \emptyset$. As a hypothesis, we get $L(\nu_P, t)$ is a BCC-ideal of X and so $0 \in L(\nu_P, t)$. Thus $\nu_P(0) \leq t = \nu_P(x)$.

Choose $t = \max\{\nu_P(x \cdot (y \cdot z)), \nu_P(y)\} \in [0, 1]$. Then $\nu_P(x \cdot (y \cdot z)) \leq t$ and $\nu_P(y) \leq t$. Thus $x \cdot (y \cdot z), y \in L(\nu_P, t) \neq \emptyset$. As a hypothesis, we get $L(\nu_P, t)$ is a BCC-ideal of X and so $x \cdot z \in L(\nu_P, t)$. Thus $\nu_P(x \cdot z) \leq t = \max\{\nu_P(x \cdot (y \cdot z)), \nu_P(y)\}$.

Hence, P is a Pythagorean fuzzy BCC-ideal of X . □

Theorem 3.4.15 P is a Pythagorean fuzzy BCC-ideal of X if and only if $U^+(\mu_P, t)$ and $L^-(\nu_P, t)$ are, if the sets are nonempty, BCC-ideals of X for every $t \in [0, 1]$.

Proof. Assume $P = (\mu_P, \nu_P)$ is a Pythagorean fuzzy BCC-ideal of X . Let $t \in [0, 1]$

be such that $U^+(\mu_P, t), L^-(\nu_P, t) \neq \emptyset$. Let $x, y, z \in X$. Then

$$\begin{aligned} x \in U^+(\mu_P, t) &\Rightarrow \mu_P(x) > t \\ &\Rightarrow \mu_P(0) \geq \mu_P(x) > t \\ &\Rightarrow 0 \in U^+(\mu_P, t), \end{aligned} \quad ((3.1.5))$$

$$\begin{aligned} x \cdot (y \cdot z), y \in U^+(\mu_P, t) &\Rightarrow \mu_P(x \cdot (y \cdot z)) > t, \mu_P(y) > t \\ &\Rightarrow \min\{\mu_P(x \cdot (y \cdot z)), \mu_P(y)\} > t \\ &\Rightarrow \mu_P(x \cdot z) \geq \min\{\mu_P(x \cdot (y \cdot z)), \mu_P(y)\} > t \quad ((3.1.15)) \\ &\Rightarrow x \cdot z \in U^+(\mu_P, t), \end{aligned}$$

$$\begin{aligned} x \in L^-(\nu_P, t) &\Rightarrow \nu_P(x) < t \\ &\Rightarrow \nu_P(0) \leq \nu_P(x) < t \\ &\Rightarrow 0 \in L^-(\nu_P, t), \end{aligned} \quad ((3.1.6))$$

and

$$\begin{aligned} x \cdot (y \cdot z), y \in L^-(\nu_P, t) &\Rightarrow \nu_P(x \cdot (y \cdot z)) < t, \nu_P(y) < t \\ &\Rightarrow \max\{\nu_P(x \cdot (y \cdot z)), \nu_P(y)\} < t \\ &\Rightarrow \nu_P(x \cdot z) \leq \max\{\nu_P(x \cdot (y \cdot z)), \nu_P(y)\} < t \quad ((3.1.16)) \\ &\Rightarrow x \cdot z \in L^-(\nu_P, t). \end{aligned}$$

Hence, $U^+(\mu_P, t)$ and $L^-(\nu_P, t)$ are BCC-ideals of X .

Conversely, assume for all $t \in [0, 1]$, $U^+(\mu_P, t)$ and $L^-(\nu_P, t)$ are BCC-ideals of X if the sets are nonempty.

Suppose there exists $x \in X$ such that $\mu_P(0) < \mu_P(x)$. Choose $t = \mu_P(0) \in [0, 1]$. Then $\mu_P(x) > t$. Thus $x \in U^+(\mu_P, t) \neq \emptyset$. As a hypothesis, we get $U^+(\mu_P, t)$ is a BCC-ideal of X and so $0 \in U^+(\mu_P, t)$. Thus $\mu_P(0) > t = \mu_P(0)$, a contradiction. Hence, $\mu_P(0) \geq \mu_P(x)$ for all $x \in X$.

Suppose there exist $x, y, z \in X$ such that $\mu_P(x \cdot z) < \min\{\mu_P(x \cdot (y \cdot z)), \mu_P(y)\}$. Choose $t = \mu_P(x \cdot z) \in [0, 1]$. Then $\mu_P(x \cdot (y \cdot z)) > t$ and $\mu_P(y) > t$. Thus $x \cdot (y \cdot z), y \in U^+(\mu_P, t) \neq \emptyset$. As a hypothesis, we get $U^+(\mu_P, t)$ is a BCC-ideal of X and so $x \cdot z \in U^+(\mu_P, t)$. Thus $\mu_P(x \cdot z) > t = \mu_P(x \cdot z)$, a contradiction. Hence, $\mu_P(x \cdot z) \geq \min\{\mu_P(x \cdot (y \cdot z)), \mu_P(y)\}$ for all $x, y \in X$.

Suppose there exists $y \in X$ such that $\nu_P(0) > \nu_P(x)$. Choose $t = \nu_P(0) \in [0, 1]$. Then $\nu_P(x) < t$. Thus $x \in L^-(\nu_P, t) \neq \emptyset$. As a hypothesis, we get $L^-(\nu_P, t)$ is a BCC-ideal of X and so $0 \in L^-(\nu_P, t)$. Thus $\nu_P(0) < t = \nu_P(0)$, a contradiction. Hence, $\nu_P(0) \leq \nu_P(x)$ for all $x, y \in X$.

Suppose there exist $x, y, z \in X$ such that $\nu_P(x \cdot z) > \max\{\nu_P(x \cdot (y \cdot z)), \nu_P(y)\}$. Choose $t = \nu_P(x) \in [0, 1]$. Then $\nu_P(x \cdot (y \cdot z)) < t$ and $\nu_P(y) < t$. Thus $x \cdot (y \cdot z), y \in L^-(\nu_P, t) \neq \emptyset$. As a hypothesis, we get $L^-(\nu_P, t)$ is a BCC-ideal of X and so $x \cdot z \in L^-(\nu_P, t)$. Thus $\nu_P(x \cdot z) < t = \nu_P(x \cdot z)$, a contradiction. Hence, $\nu_P(x \cdot z) \leq \max\{\nu_P(x \cdot (y \cdot z)), \nu_P(y)\}$ for all $x, y \in X$.

Therefore, P is a Pythagorean fuzzy BCC-ideal of X . □

Theorem 3.4.16 P is a Pythagorean fuzzy strong BCC-ideal of X if and only if $U(\mu_P, t)$ and $L(\nu_P, t)$ are, if the sets are nonempty, strong BCC-ideals for every $t \in [0, 1]$.

Proof. Assume $P = (\mu_P, \nu_P)$ is a Pythagorean fuzzy strong BCC-ideal of X . Let $t \in [0, 1]$ be such that $U(\mu_P, t), L(\nu_P, t) \neq \emptyset$. Let $x, y, z \in X$. Then

$$x \in U(\mu_P, t) \Rightarrow \mu_P(x) \geq t$$

$$\Rightarrow \mu_{\mathbb{P}}(0) \geq \mu_{\mathbb{P}}(x) \geq t \quad ((3.1.5))$$

$$\Rightarrow 0 \in U(\mu_{\mathbb{P}}, t),$$

$$(z \cdot y) \cdot (z \cdot x), y \in U(\mu_{\mathbb{P}}, t)$$

$$\Rightarrow \mu_{\mathbb{P}}((z \cdot y) \cdot (z \cdot x)) \geq t, \mu_{\mathbb{P}}(y) \geq t$$

$$\Rightarrow \min\{\mu_{\mathbb{P}}((z \cdot y) \cdot (z \cdot x)), \mu_{\mathbb{P}}(y)\} \geq t$$

$$\Rightarrow \mu_{\mathbb{P}}(x) \geq \min\{\mu_{\mathbb{P}}((z \cdot y) \cdot (z \cdot x)), \mu_{\mathbb{P}}(y)\} \geq t \quad ((3.1.17))$$

$$\Rightarrow x \in U(\mu_{\mathbb{P}}, t),$$

$$x \in L(\nu_{\mathbb{P}}, t) \Rightarrow \nu_{\mathbb{P}}(x) \leq t$$

$$\Rightarrow \nu_{\mathbb{P}}(0) \leq \nu_{\mathbb{P}}(x) \leq t \quad ((3.1.6))$$

$$\Rightarrow 0 \in L(\nu_{\mathbb{P}}, t),$$

and

$$(z \cdot y) \cdot (z \cdot x), y \in L(\nu_{\mathbb{P}}, t)$$

$$\Rightarrow \nu_{\mathbb{P}}((z \cdot y) \cdot (z \cdot x)) \leq t, \nu_{\mathbb{P}}(y) \leq t$$

$$\Rightarrow \max\{\nu_{\mathbb{P}}((z \cdot y) \cdot (z \cdot x)), \nu_{\mathbb{P}}(y)\} \leq t$$

$$\Rightarrow \nu_{\mathbb{P}}(x) \leq \max\{\nu_{\mathbb{P}}((z \cdot y) \cdot (z \cdot x)), \nu_{\mathbb{P}}(y)\} \leq t \quad ((3.1.18))$$

$$\Rightarrow x \in L(\nu_{\mathbb{P}}, t).$$

Hence, $U(\mu_{\mathbb{P}}, t)$ and $L(\nu_{\mathbb{P}}, t)$ are strong BCC-ideals of X .

Conversely, assume for all $t \in [0, 1]$, $U(\mu_{\mathbb{P}}, t)$ and $L(\nu_{\mathbb{P}}, t)$ are strong BCC-ideals of X if the sets are nonempty. Let $x, y, z \in X$.

Choose $t = \mu_{\mathbb{P}}(x) \in [0, 1]$. Then $\mu_{\mathbb{P}}(x) \geq t$. Thus $x \in U(\mu_{\mathbb{P}}, t) \neq \emptyset$. As a

hypothesis, we get $U(\mu_P, t)$ is a strong BCC-ideal of X and so $0 \in U(\mu_P, t)$. Thus $\mu_P(0) \geq t = \mu_P(x)$.

Choose $t = \min\{\mu_P((z \cdot y) \cdot (z \cdot x)), \mu_P(y)\} \in [0, 1]$. Then $\mu_P((z \cdot y) \cdot (z \cdot x)) \geq t$ and $\mu_P(y) \geq t$. Thus $(z \cdot y) \cdot (z \cdot x), y \in U(\mu_P, t) \neq \emptyset$. As a hypothesis, we get $U(\mu_P, t)$ is a strong BCC-ideal of X and so $x \in U(\mu_P, t)$. Thus $\mu_P(x) \geq t = \min\{\mu_P((z \cdot y) \cdot (z \cdot x)), \mu_P(y)\}$.

Choose $t = \nu_P(x) \in [0, 1]$. The $\nu_P(x) \leq t$. Thus $x \in L(\nu_P, t) \neq \emptyset$. As a hypothesis, we get $L(\nu_P, t)$ is a strong BCC-ideal of X and so $0 \in L(\nu_P, t)$. Thus $\nu_P(0) \leq t = \nu_P(x)$.

Choose $t = \max\{\nu_P((z \cdot y) \cdot (z \cdot x)), \nu_P(y)\} \in [0, 1]$. Then $\nu_P((z \cdot y) \cdot (z \cdot x)) \leq t$ and $\nu_P(y) \leq t$. Thus $(z \cdot y) \cdot (z \cdot x), y \in L(\nu_P, t) \neq \emptyset$. As a hypothesis, we get $L(\nu_P, t)$ is a strong BCC-ideal of X and so $x \in L(\nu_P, t)$. Thus $\nu_P(x) \geq t = \max\{\nu_P((z \cdot y) \cdot (z \cdot x)), \nu_P(y)\}$.

Hence, P is a Pythagorean fuzzy strong BCC-ideal of X . □

Theorem 3.4.17 P is a Pythagorean fuzzy strong BCC-ideal of X if and only if $U^+(\mu_P, t)$ and $L^-(\nu_P, t)$ are, if the sets are nonempty, strong BCC-ideals of X for every $t \in [0, 1]$.

Proof. Assume $P = (\mu_P, \nu_P)$ is a Pythagorean fuzzy strong BCC-ideal of X . Let $t \in [0, 1]$ be such that $U^+(\mu_P, t), L^-(\nu_P, t) \neq \emptyset$. Let $x, y, z \in X$. Then

$$\begin{aligned} x \in U^+(\mu_P, t) &\Rightarrow \mu_P(x) > t \\ &\Rightarrow \mu_P(0) \geq \mu_P(x) > t && ((3.1.5)) \\ &\Rightarrow 0 \in U^+(\mu_P, t), \end{aligned}$$

$$(z \cdot y) \cdot (z \cdot x), y \in U^+(\mu_P, t)$$

$$\begin{aligned}
&\Rightarrow \mu_{\mathbb{P}}((z \cdot y) \cdot (z \cdot x)) > t, \mu_{\mathbb{P}}(y) > t \\
&\Rightarrow \min\{\mu_{\mathbb{P}}((z \cdot y) \cdot (z \cdot x)), \mu_{\mathbb{P}}(y)\} > t \\
&\Rightarrow \mu_{\mathbb{P}}(x) \geq \min\{\mu_{\mathbb{P}}((z \cdot y) \cdot (z \cdot x)), \mu_{\mathbb{P}}(y)\} > t \quad ((3.1.17)) \\
&\Rightarrow x \in U^+(\mu_{\mathbb{P}}, t),
\end{aligned}$$

$$\begin{aligned}
x \in L^-(\nu_{\mathbb{P}}, t) &\Rightarrow \nu_{\mathbb{P}}(x) < t \\
&\Rightarrow \nu_{\mathbb{P}}(0) \leq \nu_{\mathbb{P}}(x) < t \\
&\Rightarrow 0 \in L^-(\nu_{\mathbb{P}}, t),
\end{aligned} \quad ((3.1.6))$$

and

$$\begin{aligned}
(z \cdot y) \cdot (z \cdot x), y \in L^-(\nu_{\mathbb{P}}, t) \\
&\Rightarrow \nu_{\mathbb{P}}((z \cdot y) \cdot (z \cdot x)) < t, \nu_{\mathbb{P}}(y) < t \\
&\Rightarrow \max\{\nu_{\mathbb{P}}((z \cdot y) \cdot (z \cdot x)), \nu_{\mathbb{P}}(y)\} < t \\
&\Rightarrow \nu_{\mathbb{P}}(x) \leq \max\{\nu_{\mathbb{P}}((z \cdot y) \cdot (z \cdot x)), \nu_{\mathbb{P}}(y)\} < t \quad ((3.1.18)) \\
&\Rightarrow x \in L^-(\nu_{\mathbb{P}}, t).
\end{aligned}$$

Hence, $U^+(\mu_{\mathbb{P}}, t)$ and $L^-(\nu_{\mathbb{P}}, t)$ are strong BCC-ideals of X .

Conversely, assume for all $t \in [0, 1]$, $U^+(\mu_{\mathbb{P}}, t)$ and $L^-(\nu_{\mathbb{P}}, t)$ are strong BCC-ideals of X if the sets are nonempty.

Suppose there exists $x \in X$ such that $\mu_{\mathbb{P}}(0) < \mu_{\mathbb{P}}(x)$. Choose $t = \mu_{\mathbb{P}}(0) \in [0, 1]$. Then $\mu_{\mathbb{P}}(x) > t$. Thus $x \in U^+(\mu_{\mathbb{P}}, t) \neq \emptyset$. As a hypothesis, we get $U^+(\mu_{\mathbb{P}}, t)$ is a strong BCC-ideal of X and so $0 \in U^+(\mu_{\mathbb{P}}, t)$. Thus $\mu_{\mathbb{P}}(0) > t = \mu_{\mathbb{P}}(0)$, a contradiction. Hence, $\mu_{\mathbb{P}}(0) \geq \mu_{\mathbb{P}}(x)$ for all $x \in X$.

Suppose there exist $x, y, z \in X$ such that $\mu_{\mathbb{P}}(x) < \min\{\mu_{\mathbb{P}}((z \cdot y) \cdot (z \cdot$

$x)), \mu_P(y)\}$. Choose $t = \mu_P(x) \in [0, 1]$. Then $\mu_P((z \cdot y) \cdot (z \cdot x)) > t$ and $\mu_P(y) > t$. Thus $(z \cdot y) \cdot (z \cdot x), y \in U^+(\mu_P, t) \neq \emptyset$. As a hypothesis, we get $U^+(\mu_P, t)$ is a strong BCC-ideal of X and so $x \in U^+(\mu_P, t)$. Thus $\mu_P(x) > t = \mu_P(x)$, a contradiction. Hence, $\mu_P(x) \geq \min\{\mu_P((z \cdot y) \cdot (z \cdot x)), \mu_P(y)\}$ for all $x, y \in X$.

Suppose there exists $y \in X$ such that $\nu_P(0) > \nu_P(x)$. Choose $t = \nu_P(0) \in [0, 1]$. Then $\nu_P(x) < t$. Thus $x \in L^-(\nu_P, t) \neq \emptyset$. As a hypothesis, we get $L^-(\nu_P, t)$ is a strong BCC-ideal of X and so $0 \in L^-(\nu_P, t)$. Thus $\nu_P(0) < t = \nu_P(0)$, a contradiction. Hence, $\nu_P(0) \leq \nu_P(x)$ for all $x, y \in X$.

Suppose there exist $x, y, z \in X$ such that $\nu_P(x) > \max\{\nu_P((z \cdot y) \cdot (z \cdot x)), \nu_P(y)\}$. Choose $t = \nu_P(x) \in [0, 1]$. Then $\nu_P((z \cdot y) \cdot (z \cdot x)) < t$ and $\nu_P(y) < t$. Thus $(z \cdot y) \cdot (z \cdot x), y \in L^-(\nu_P, t) \neq \emptyset$. As a hypothesis, we get $L^-(\nu_P, t)$ is a strong BCC-ideal of X and so $x \in L^-(\nu_P, t)$. Thus $\nu_P(x) < t = \nu_P(x)$, a contradiction. Hence, $\nu_P(x) \leq \max\{\nu_P((z \cdot y) \cdot (z \cdot x)), \nu_P(y)\}$ for all $x, y \in X$.

Therefore, P is a Pythagorean fuzzy strong BCC-ideal of X . \square

Theorem 3.4.18 P is a Pythagorean fuzzy strong BCC-ideal of X if and only if $E(\mu_P, \mu_P(0))$ and $E(\nu_P, \nu_P(0))$ are strong BCC-ideals of X .

Proof. Assume $P = (\mu_P, \nu_P)$ is a Pythagorean fuzzy strong BCC-ideal of X . Since P is constant, we have

$$(\forall x \in X) \begin{pmatrix} \mu_P(x) = \mu_P(0) \\ \nu_P(x) = \nu_P(0) \end{pmatrix}.$$

Thus $x \in E(\mu_P, \mu_P(0))$ and $x \in E(\nu_P, \nu_P(0))$ and so $E(\mu_P, \mu_P(0)) = X$ and $E(\nu_P, \nu_P(0)) = X$. Hence, $E(\mu_P, \mu_P(0))$ and $E(\nu_P, \nu_P(0))$ are strong BCC-ideals of X .

Conversely, assume for all $E(\mu_P, \mu_P(0))$ and $E(\nu_P, \nu_P(0))$ are strong BCC-

ideals of X . Then $E(\mu_P, \mu_P(0)) = X$ and $E(\nu_P, \nu_P(0)) = X$. We consider

$$(\forall x \in X) \begin{pmatrix} \mu_P(x) = \mu_P(0) \\ \nu_P(x) = \nu_P(0) \end{pmatrix}.$$

Thus P is constant, that is, P is a Pythagorean fuzzy strong BCC-ideal of X . \square

3.5 The operations on Pythagorean fuzzy sets

Theorem 3.5.1 *The intersection of any nonempty family of Pythagorean fuzzy BCC-subalgebras of X is also a Pythagorean fuzzy BCC-subalgebra.*

Proof. Assume that P_i is a Pythagorean fuzzy BCC-subalgebra of X for all $i \in I$.

Let $x, y \in X$. Then

$$\begin{aligned} \mu_{\bigwedge_{i \in I} P_i}(x \cdot y) &= \inf\{\mu_{P_i}(x \cdot y)\}_{i \in I} \\ &\geq \inf\{\min\{\mu_{P_i}(x), \mu_{P_i}(y)\}\}_{i \in I} \\ &= \min\{\inf\{\mu_{P_i}(x)\}_{i \in I}, \inf\{\mu_{P_i}(y)\}_{i \in I}\} \\ &= \min\{\mu_{\bigwedge_{i \in I} P_i}(x), \mu_{\bigwedge_{i \in I} P_i}(y)\} \text{ and} \\ \nu_{\bigwedge_{i \in I} P_i}(x \cdot y) &= \sup\{\nu_{P_i}(x \cdot y)\}_{i \in I} \\ &\leq \sup\{\max\{\nu_{P_i}(x), \nu_{P_i}(y)\}\}_{i \in I} \\ &= \max\{\sup\{\nu_{P_i}(x)\}_{i \in I}, \sup\{\nu_{P_i}(y)\}_{i \in I}\} \\ &= \max\{\nu_{\bigwedge_{i \in I} P_i}(x), \nu_{\bigwedge_{i \in I} P_i}(y)\}. \end{aligned}$$

Hence, $\bigwedge_{i \in I} P_i$ is a Pythagorean fuzzy BCC-subalgebra of X . \square

The following example show that the union of two Pythagorean fuzzy BCC-subalgebras of BCC-algebra may be not a Pythagorean fuzzy BCC-subalgebra.

Example 3.5.2 Let $X = \{0, 1, 2, 3\}$ be a BCC-algebra with a fixed element 0 and a binary operation \cdot defined by the following Cayley table:

\cdot	0	1	2	3
0	0	1	2	3
1	0	0	1	3
2	0	0	0	3
3	0	0	1	0

We define two Pythagorean fuzzy sets $P_1 = (\mu_{P_1}, \nu_{P_1})$ and $P_2 = (\mu_{P_2}, \nu_{P_2})$ as follows:

X	0	1	2	3
μ_{P_1}	0.8	0.3	0.8	0.2
ν_{P_1}	0.2	0.5	0.2	0.6
μ_{P_2}	0.8	0.2	0.1	0.6
ν_{P_2}	0.2	0.8	0.9	0.7

Then P_1 and P_2 are Pythagorean fuzzy BCC-subalgebras of X . Since $\mu_{P_1 \vee P_2}(3 \cdot 2) = \mu_{P_1 \vee P_2}(1) = 0.3 \not\geq 0.6 = \min\{0.6, 0.8\} = \min\{\mu_{P_1 \vee P_2}(3), \mu_{P_1 \vee P_2}(2)\}$, we have $P_1 \vee P_2$ is not a Pythagorean fuzzy BCC-subalgebra of X .

Theorem 3.5.3 *The intersection of any nonempty family of Pythagorean fuzzy near BCC-filters of X is also a Pythagorean fuzzy near BCC-filter.*

Proof. Assume that P_i is a Pythagorean fuzzy near BCC-filter of X for all $i \in I$. Then

$$\begin{aligned}
 \mu_{\bigwedge_{i \in I} P_i}(x \cdot y) &= \inf\{\mu_{P_i}(x \cdot y)\}_{i \in I} \\
 &\geq \inf\{\mu_{P_i}(y)\}_{i \in I} \\
 &= \mu_{\bigwedge_{i \in I} P_i}(y) \text{ and} \\
 \nu_{\bigwedge_{i \in I} P_i}(x \cdot y) &= \sup\{\nu_{P_i}(x \cdot y)\}_{i \in I}
 \end{aligned}$$

$$\begin{aligned} &\leq \sup\{\nu_{P_i}(y)\}_{i \in I} \\ &= \nu_{\bigwedge_{i \in I} P_i}(y). \end{aligned}$$

Hence, $\bigwedge_{i \in I} P_i$ is a Pythagorean fuzzy near BCC-filter of X . \square

Theorem 3.5.4 *The union of any nonempty family of Pythagorean fuzzy near BCC-filters of X is also a Pythagorean fuzzy near BCC-filter.*

Proof. Assume that P_i is a Pythagorean fuzzy near BCC-filter of X for all $i \in I$. Then

$$\begin{aligned} \mu_{\bigvee_{i \in I} P_i}(x \cdot y) &= \sup\{\mu_{P_i}(x \cdot y)\}_{i \in I} \\ &\geq \sup\{\mu_{P_i}(y)\}_{i \in I} \\ &= \mu_{\bigvee_{i \in I} P_i}(y) \text{ and} \\ \nu_{\bigvee_{i \in I} P_i}(x \cdot y) &= \inf\{\nu_{P_i}(x \cdot y)\}_{i \in I} \\ &\leq \inf\{\nu_{P_i}(y)\}_{i \in I} \\ &= \nu_{\bigvee_{i \in I} P_i}(y). \end{aligned}$$

Hence, $\bigvee_{i \in I} P_i$ is a Pythagorean fuzzy near BCC-filter of X . \square

Theorem 3.5.5 *The intersection of any nonempty family of Pythagorean fuzzy BCC-filters of X is also a Pythagorean fuzzy BCC-filter.*

Proof. Assume that P_i be a Pythagorean fuzzy BCC-filter of X for all $i \in I$. Then

$$\begin{aligned} \mu_{\bigwedge_{i \in I} P_i}(0) &= \inf\{\mu_{P_i}(0)\}_{i \in I} \\ &\geq \inf\{\mu_{P_i}(x)\}_{i \in I} \\ &= \mu_{\bigwedge_{i \in I} P_i}(x), \end{aligned}$$

$$\begin{aligned}
\mu_{\bigwedge_{i \in I} P_i}(y) &= \inf\{\mu_{P_i}(y)\}_{i \in I} \\
&\geq \inf\{\min\{\mu_{P_i}(x \cdot y), \mu_{P_i}(x)\}\}_{i \in I} \\
&= \min\{\inf\{\mu_{P_i}(x \cdot y)\}_{i \in I}, \inf\{\mu_{P_i}(x)\}_{i \in I}\} \\
&= \min\{\mu_{\bigwedge_{i \in I} P_i}(x \cdot y), \mu_{\bigwedge_{i \in I} P_i}(x)\}, \\
\nu_{\bigwedge_{i \in I} P_i}(0) &= \sup\{\nu_{P_i}(0)\}_{i \in I} \\
&\leq \sup\{\nu_{P_i}(x)\}_{i \in I} \\
&= \nu_{\bigwedge_{i \in I} P_i}(x), \text{ and} \\
\nu_{\bigwedge_{i \in I} P_i}(y) &= \sup\{\nu_{P_i}(y)\}_{i \in I} \\
&\leq \sup\{\max\{\nu_{P_i}(x \cdot y), \nu_{P_i}(x)\}\}_{i \in I} \\
&= \max\{\sup\{\nu_{P_i}(x \cdot y)\}_{i \in I}, \inf\{\nu_{P_i}(x)\}_{i \in I}\} \\
&= \max\{\nu_{\bigwedge_{i \in I} P_i}(x \cdot y), \nu_{\bigwedge_{i \in I} P_i}(x)\}.
\end{aligned}$$

Hence, $\bigwedge_{i \in I} P_i$ is a Pythagorean fuzzy BCC-filter of X . □

The following example show that the union of two Pythagorean fuzzy BCC-filters of BCC-algebra may be not a Pythagorean fuzzy BCC-filter.

Example 3.5.6 Let $X = \{0, 1, 2, 3\}$ be a BCC-algebra with a fixed element 0 and a binary operation \cdot defined by the following Cayley table:

\cdot	0	1	2	3
0	0	1	2	3
1	0	0	2	2
2	0	1	0	1
3	0	0	0	0

We define two Pythagorean fuzzy sets $P_1 = (\mu_{P_1}, \nu_{P_1})$ and $P_2 = (\mu_{P_2}, \nu_{P_2})$ as

follows:

X	0	1	2	3
μ_{P_1}	0.7	0.7	0.4	0.4
ν_{P_1}	0.2	0.2	0.5	0.5
μ_{P_2}	0.8	0.2	0.5	0.2
ν_{P_2}	0.2	0.6	0.3	0.6

Then P_1 and P_2 are Pythagorean fuzzy BCC-filters of X . Since $\mu_{P_1 \vee P_2}(3) = 0.4 \not\geq 0.5 = \min\{0.5, 0.7\} = \min\{\mu_{P_1 \vee P_2}(2), \mu_{P_1 \vee P_2}(1)\} = \min\{\mu_{P_1 \vee P_2}(1 \cdot 3), \mu_{P_1 \vee P_2}(1)\}$, we have $P_1 \vee P_2$ is not a Pythagorean fuzzy BCC-filter of X .

Theorem 3.5.7 *The intersection of any nonempty family of Pythagorean fuzzy implicative BCC-filters of a BCC-algebra X is also a Pythagorean fuzzy implicative BCC-filter.*

Proof. Assume that P_i is a Pythagorean fuzzy implicative BCC-filter of X for all $i \in I$. Let $x, y \in X$. Then

$$\begin{aligned}
\mu_{\bigwedge_{i \in I} P_i}(0) &= \inf\{\mu_{P_i}(0)\}_{i \in I} \\
&\geq \inf\{\mu_{P_i}(x)\}_{i \in I} \\
&= \mu_{\bigwedge_{i \in I} P_i}(x), \\
\mu_{\bigwedge_{i \in I} P_i}(x \cdot z) &= \inf\{\mu_{P_i}(x \cdot z)\}_{i \in I} \\
&\geq \inf\{\min\{\mu_{P_i}(x \cdot (y \cdot z)), \mu_{P_i}(x \cdot y)\}\}_{i \in I} \\
&= \min\{\inf\{\mu_{P_i}(x \cdot (y \cdot z))\}_{i \in I}, \inf\{\mu_{P_i}(x \cdot y)\}_{i \in I}\} \\
&= \min\{\mu_{\bigwedge_{i \in I} P_i}(x \cdot (y \cdot z)), \mu_{\bigwedge_{i \in I} P_i}(x \cdot y)\}, \\
\nu_{\bigwedge_{i \in I} P_i}(0) &= \sup\{\nu_{P_i}(0)\}_{i \in I} \\
&\leq \sup\{\nu_{P_i}(x)\}_{i \in I} \\
&= \nu_{\bigwedge_{i \in I} P_i}(x), \text{ and} \\
\nu_{\bigwedge_{i \in I} P_i}(x \cdot z) &= \sup\{\nu_{P_i}(x \cdot z)\}_{i \in I}
\end{aligned}$$

$$\begin{aligned}
&\leq \sup\{\max\{\nu_{P_i}(x \cdot (y \cdot z)), \nu_{P_i}(x \cdot y)\}\}_{i \in I} \\
&= \max\{\sup\{\nu_{P_i}(x \cdot (y \cdot z))\}_{i \in I}, \sup\{\nu_{P_i}(x \cdot y)\}_{i \in I}\} \\
&= \max\{\nu_{\bigwedge_{i \in I} P_i}(x \cdot (y \cdot z)), \nu_{\bigwedge_{i \in I} P_i}(x \cdot y)\}.
\end{aligned}$$

Hence, $\bigwedge_{i \in I} P_i$ is a Pythagorean fuzzy implicative BCC-filter of X . \square

The following example shows that the union of two Pythagorean fuzzy implicative BCC-filters of BCC-algebra may be not a Pythagorean fuzzy implicative BCC-filter.

Example 3.5.8 Let $X = \{0, 1, 2, 3\}$ be a BCC-algebra with a fixed element 0 and a binary operation \cdot defined by the following Cayley table:

\cdot	0	1	2	3
0	0	1	2	3
1	0	0	2	2
2	0	1	0	1
3	0	0	0	0

We define two Pythagorean fuzzy sets $P_1 = (\mu_{P_1}, \nu_{P_1})$ and $P_2 = (\mu_{P_2}, \nu_{P_2})$ as follows:

X	0	1	2	3
μ_{P_1}	0.8	0.8	0.1	0.1
ν_{P_1}	0.2	0.2	0.3	0.3
μ_{P_2}	0.7	0.2	0.3	0.2
ν_{P_2}	0.1	0.4	0.3	0.4

Then P_1 and P_2 are Pythagorean fuzzy implicative BCC-filters of X . Since

$$\begin{aligned}
\mu_{P_1 \vee P_2}(0 \cdot 3) &= \mu_{P_1 \vee P_2}(3) \\
&= 0.2
\end{aligned}$$

$$\begin{aligned}
&\not\geq 0.3 \\
&= \min\{0.3, 0.8\} \\
&= \min\{\mu_{P_1 \vee P_2}(2), \mu_{P_1 \vee P_2}(1)\} \\
&= \min\{\mu_{P_1 \vee P_2}(0 \cdot (1 \cdot 3)), \mu_{P_1 \vee P_2}(0 \cdot 1)\},
\end{aligned}$$

we have $P_1 \vee P_2$ is not a Pythagorean fuzzy implicative BCC-filter of X .

Theorem 3.5.9 *The intersection of any nonempty family of Pythagorean fuzzy comparative BCC-filters of a BCC-algebra X is also a Pythagorean fuzzy comparative BCC-filter.*

Proof. Assume that P_i is a Pythagorean fuzzy comparative BCC-filter of X for all $i \in I$. Then

$$\begin{aligned}
\mu_{\bigwedge_{i \in I} P_i}(0) &= \inf\{\mu_{P_i}(0)\}_{i \in I} \\
&\geq \inf\{\mu_{P_i}(x)\}_{i \in I} \\
&= \mu_{\bigwedge_{i \in I} P_i}(x), \\
\mu_{\bigwedge_{i \in I} P_i}(y) &= \inf\{\mu_{P_i}(y)\}_{i \in I} \\
&\geq \inf\{\min\{\mu_{P_i}(x \cdot ((y \cdot z) \cdot y)), \mu_{P_i}(x)\}\}_{i \in I} \\
&= \min\{\inf\{\mu_{P_i}(x \cdot ((y \cdot z) \cdot y))\}_{i \in I}, \inf\{\mu_{P_i}(x)\}_{i \in I}\} \\
&= \min\{\mu_{\bigwedge_{i \in I} P_i}(x \cdot ((y \cdot z) \cdot y)), \mu_{\bigwedge_{i \in I} P_i}(x)\}, \\
\nu_{\bigwedge_{i \in I} P_i}(0) &= \sup\{\nu_{P_i}(0)\}_{i \in I} \\
&\leq \sup\{\nu_{P_i}(x)\}_{i \in I} \\
&= \nu_{\bigwedge_{i \in I} P_i}(x), \text{ and} \\
\nu_{\bigwedge_{i \in I} P_i}(y) &= \sup\{\nu_{P_i}(y)\}_{i \in I} \\
&\leq \sup\{\max\{\nu_{P_i}(x \cdot ((y \cdot z) \cdot y)), \nu_{P_i}(x)\}\}_{i \in I} \\
&= \max\{\sup\{\nu_{P_i}(x \cdot ((y \cdot z) \cdot y))\}_{i \in I}, \sup\{\nu_{P_i}(x)\}_{i \in I}\}
\end{aligned}$$

$$= \max\{\nu_{\bigwedge_{i \in I} P_i}(x \cdot ((y \cdot z) \cdot y)), \nu_{\bigwedge_{i \in I} P_i}(x)\}.$$

Hence, $\bigwedge_{i \in I} P_i$ is a Pythagorean fuzzy comparative BCC-filter of X . \square

The following example shows that the union of two Pythagorean fuzzy comparative BCC-filters of BCC-algebra may be not a Pythagorean fuzzy comparative BCC-filter.

Example 3.5.10 By Example 3.5.8, we have P_1 and P_2 are Pythagorean fuzzy comparative BCC-filters of X . Since

$$\begin{aligned} \mu_{P_1 \vee P_2}(3) &= 0.2 \\ &\neq 0.3 \\ &= \min\{0.3, 0.8\} \\ &= \min\{\mu_{P_1 \vee P_2}(2), \mu_{P_2 \vee P_2}(1)\} \\ &= \min\{\mu_{P_1 \vee P_2}(1 \cdot ((3 \cdot 0) \cdot 3)), \mu_{P_1 \vee P_2}(1)\}, \end{aligned}$$

we have $P_1 \vee P_2$ is not a Pythagorean fuzzy comparative BCC-filter of X .

Theorem 3.5.11 *The intersection of any nonempty family of Pythagorean fuzzy shift BCC-filters of a BCC-algebra X is also a Pythagorean fuzzy shift BCC-filter.*

Proof. Assume that P_i be a Pythagorean fuzzy shift BCC-filter of X for all $i \in I$. Then

$$\begin{aligned} \mu_{\bigwedge_{i \in I} P_i}(0) &= \inf\{\mu_{P_i}(0)\}_{i \in I} \\ &\geq \inf\{\mu_{P_i}(x)\}_{i \in I} \\ &= \mu_{\bigwedge_{i \in I} P_i}(x), \\ \mu_{\bigwedge_{i \in I} P_i}(((z \cdot y) \cdot y) \cdot z) &= \inf\{\mu_{P_i}(((z \cdot y) \cdot y) \cdot z)\}_{i \in I} \\ &\geq \inf\{\min\{\mu_{P_i}(x \cdot (y \cdot z)), \mu_{P_i}(x)\}\}_{i \in I} \end{aligned}$$

$$\begin{aligned}
&= \min\{\inf\{\mu_{P_i}(x \cdot (y \cdot z))\}_{i \in I}, \inf\{\mu_{P_i}(x)\}_{i \in I}\} \\
&= \min\{\mu_{\bigwedge_{i \in I} P_i}(x \cdot (y \cdot z)), \mu_{\bigwedge_{i \in I} P_i}(x)\}, \\
\nu_{\bigwedge_{i \in I} P_i}(0) &= \sup\{\nu_{P_i}(0)\}_{i \in I} \\
&\leq \sup\{\nu_{P_i}(x)\}_{i \in I} \\
&= \nu_{\bigwedge_{i \in I} P_i}(x), \text{ and} \\
\nu_{\bigwedge_{i \in I} P_i}(((z \cdot y) \cdot y) \cdot z) &= \sup\{\nu_{P_i}(((z \cdot y) \cdot y) \cdot z)\}_{i \in I} \\
&\leq \sup\{\max\{\nu_{P_i}(x \cdot (y \cdot z)), \nu_{P_i}(x)\}\}_{i \in I} \\
&= \max\{\sup\{\nu_{P_i}(x \cdot (y \cdot z))\}_{i \in I}, \inf\{\nu_{P_i}(x)\}_{i \in I}\} \\
&= \max\{\nu_{\bigwedge_{i \in I} P_i}(x \cdot (y \cdot z)), \nu_{\bigwedge_{i \in I} P_i}(x)\}.
\end{aligned}$$

Hence, $\bigwedge_{i \in I} P_i$ is a Pythagorean fuzzy shift BCC-filter of X . \square

The following example shows that the union of two Pythagorean fuzzy shift BCC-filters of BCC-algebra may be not a Pythagorean fuzzy shift BCC-filter.

Example 3.5.12 By Example 3.5.8, we have P_1 and P_2 are Pythagorean fuzzy shift BCC-filters of X . Since

$$\begin{aligned}
\mu_{P_1 \vee P_2}(((3 \cdot 0) \cdot 0) \cdot 3) &= \mu_{P_1 \vee P_2}(3) \\
&= 0.2 \\
&\not\geq 0.3 \\
&= \min\{0.8, 0.3\} \\
&= \min\{\mu_{P_1 \vee P_2}(1), \mu_{P_1 \vee P_2}(2)\} \\
&= \min\{\mu_{P_1 \vee P_2}(2 \cdot (0 \cdot 3)), \mu_{P_1 \vee P_2}(2)\},
\end{aligned}$$

we have $P_1 \vee P_2$ is not a Pythagorean fuzzy shift BCC-filter of X .

Theorem 3.5.13 *The intersection of any nonempty family of Pythagorean fuzzy*

BCC-ideals of X is also a Pythagorean fuzzy BCC-ideal.

Proof. Assume that P_i be a Pythagorean fuzzy BCC-ideal of X for all $i \in I$.

Then

$$\begin{aligned}
 \mu_{\bigwedge_{i \in I} P_i}(0) &= \inf\{\mu_{P_i}(0)\}_{i \in I} \\
 &\geq \inf\{\mu_{P_i}(x)\}_{i \in I} \\
 &= \mu_{\bigwedge_{i \in I} P_i}(x), \\
 \mu_{\bigwedge_{i \in I} P_i}(x \cdot z) &= \inf\{\mu_{P_i}(x \cdot z)\}_{i \in I} \\
 &\geq \inf\{\min\{\mu_{P_i}(x \cdot (y \cdot z)), \mu_{P_i}(y)\}\}_{i \in I} \\
 &= \min\{\inf\{\mu_{P_i}(x \cdot (y \cdot z))\}_{i \in I}, \inf\{\mu_{P_i}(y)\}_{i \in I}\} \\
 &= \min\{\mu_{\bigwedge_{i \in I} P_i}(x \cdot (y \cdot z)), \mu_{\bigwedge_{i \in I} P_i}(y)\}, \\
 \nu_{\bigwedge_{i \in I} P_i}(0) &= \sup\{\nu_{P_i}(0)\}_{i \in I} \\
 &\leq \sup\{\nu_{P_i}(x)\}_{i \in I} \\
 &= \nu_{\bigwedge_{i \in I} P_i}(x), \text{ and} \\
 \nu_{\bigwedge_{i \in I} P_i}(x \cdot z) &= \sup\{\nu_{P_i}(x \cdot z)\}_{i \in I} \\
 &\leq \sup\{\max\{\nu_{P_i}(x \cdot (y \cdot z)), \nu_{P_i}(y)\}\}_{i \in I} \\
 &= \max\{\sup\{\nu_{P_i}(x \cdot (y \cdot z))\}_{i \in I}, \inf\{\nu_{P_i}(y)\}_{i \in I}\} \\
 &= \max\{\nu_{\bigwedge_{i \in I} P_i}(x \cdot (y \cdot z)), \nu_{\bigwedge_{i \in I} P_i}(y)\}.
 \end{aligned}$$

Hence, $\bigwedge_{i \in I} P_i$ is a Pythagorean fuzzy BCC-ideal of X . □

The following example show that the union of two Pythagorean fuzzy BCC-ideals of BCC-algebra may be not a Pythagorean fuzzy BCC-ideal.

Example 3.5.14 In Example 3.5.6 We define two Pythagorean fuzzy sets $P_1 =$

(μ_{P_1}, ν_{P_1}) and $P_2 = (\mu_{P_2}, \nu_{P_2})$ as follows:

X	0	1	2	3
μ_{P_1}	1	0.4	0.7	0.4
ν_{P_1}	0	0.5	0.3	0.5
μ_{P_2}	0.9	0.7	0.1	0.1
ν_{P_2}	0.2	0.4	0.9	0.9

Then P_1 and P_2 are Pythagorean fuzzy BCC-ideals of X . Since $\mu_{P_1 \vee P_2}(0 \cdot 3) = \mu_{P_1 \vee P_2}(3) = 0.4 \not\geq 0.7 = \min\{0.7, 0.7\} = \min\{\mu_{P_1 \vee P_2}(1), \mu_{P_1 \vee P_2}(2)\} = \min\{\mu_{P_1 \vee P_2}(0 \cdot (2 \cdot 3)), \mu_{P_1 \vee P_2}(2)\}$, we have $P_1 \vee P_2$ is not a Pythagorean fuzzy BCC-ideal of X .

Theorem 3.5.15 *The intersection of any nonempty family of Pythagorean fuzzy strong BCC-ideals of X is also a Pythagorean fuzzy strong BCC-ideal. Moreover, the union of any nonempty family of Pythagorean fuzzy strong BCC-ideals of X is also a Pythagorean fuzzy strong BCC-ideal.*

CHAPTER IV

ROUGH PYTHAGOREAN FUZZY SETS

4.1 Rough Pythagorean fuzzy sets in BCC-algebras

We introduce necessary define for study rough Pythagorean fuzzy sets in BCC-algebras.

Definition 4.1.1 Let ρ be an equivalence relation on X . Then a nonempty subset S of X is called

- (1) an *upper rough implicative BCC-filter* of X if $\rho^+(S)$ is an implicative BCC-filter of X ,
- (2) an *upper rough comparative BCC-filter* of X if $\rho^+(S)$ is a comparative BCC-filter of X ,
- (3) an *upper rough shift BCC-filter* of X if $\rho^+(S)$ is a shift BCC-filter of X ,
- (4) a *lower rough implicative BCC-filter* of X if $\emptyset \neq \rho^-(S)$ is an implicative BCC-filter of X ,
- (5) a *lower rough comparative BCC-filter* of X if $\emptyset \neq \rho^-(S)$ is a comparative BCC-filter of X ,
- (6) a *lower rough shift BCC-filter* of X if $\emptyset \neq \rho^-(S)$ is a of X ,
- (7) a *rough implicative BCC-filter* of X if it is both an upper rough implicative BCC-filter and a lower rough implicative BCC-filter of X ,
- (8) a *rough comparative BCC-filter* of X if it is both an upper rough comparative BCC-filter and a lower rough comparative BCC-filter of X , and
- (9) a *rough shift BCC-filter* of X if it is both an upper rough shift BCC-filter and a lower rough shift BCC-filter of X .

Next, we apply the concept of rough Pythagorean fuzzy sets to BCC-algebras and introduce the twenty-four types of rough Pythagorean fuzzy sets in BCC-algebras.

Definition 4.1.2 Let ρ be an equivalence relation on X . Then a Pythagorean fuzzy sets $P = (\mu_P, \nu_P)$ in X is called

- (1) an *upper rough Pythagorean fuzzy BCC-subalgebra* of X if $\rho^+(P)$ is a Pythagorean fuzzy BCC-subalgebra of X ,
- (2) an *upper rough Pythagorean fuzzy near BCC-filter* of X if $\rho^+(P)$ is a Pythagorean fuzzy near BCC-filter of X ,
- (3) an *upper rough Pythagorean fuzzy BCC-filter* of X if $\rho^+(P)$ is a Pythagorean fuzzy BCC-filter of X ,
- (4) an *upper rough Pythagorean fuzzy implicative BCC-filter* of X if $\rho^+(P)$ is a Pythagorean fuzzy implicative BCC-filter of X ,
- (5) an *upper rough Pythagorean fuzzy comparative BCC-filter* of X if $\rho^+(P)$ is a Pythagorean fuzzy comparative BCC-filter of X ,
- (6) an *upper rough Pythagorean fuzzy shift BCC-filter* of X if $\rho^+(P)$ is a Pythagorean fuzzy shift BCC-filter of X ,
- (7) an *upper rough Pythagorean fuzzy BCC-ideal* of X if $\rho^+(P)$ is a Pythagorean fuzzy BCC-ideal of X ,
- (8) an *upper rough Pythagorean fuzzy strong BCC-ideal* of X if $\rho^+(P)$ is a Pythagorean fuzzy strong BCC-ideal of X ,
- (9) a *lower rough Pythagorean fuzzy BCC-subalgebra* of X if $\rho^-(P)$ is a Pythagorean fuzzy BCC-subalgebra of X ,

- (10) a *lower rough Pythagorean fuzzy near BCC-filter* of X if $\rho^-(P)$ is a Pythagorean fuzzy near BCC-filter of X ,
- (11) a *lower rough Pythagorean fuzzy BCC-filter* of X if $\rho^-(P)$ is a Pythagorean fuzzy BCC-filter of X ,
- (12) a *lower rough Pythagorean fuzzy implicative BCC-filter* of X if $\rho^-(P)$ is a Pythagorean fuzzy implicative BCC-filter of X ,
- (13) a *lower rough Pythagorean fuzzy comparative BCC-filter* of X if $\rho^-(P)$ is a Pythagorean fuzzy comparative BCC-filter of X ,
- (14) a *lower rough Pythagorean fuzzy shift BCC-filter* of X if $\rho^-(P)$ is a Pythagorean fuzzy shift BCC-filter of X ,
- (15) a *lower rough Pythagorean fuzzy BCC-ideal* of X if $\rho^-(P)$ is a Pythagorean fuzzy BCC-ideal of X ,
- (16) a *lower rough Pythagorean fuzzy strong BCC-ideal* of X if $\rho^-(P)$ is a Pythagorean fuzzy strong BCC-ideal of X ,
- (17) a *rough Pythagorean fuzzy BCC-subalgebra* of X if it is both an upper rough Pythagorean fuzzy BCC-subalgebra and a lower rough Pythagorean fuzzy BCC-subalgebra of X ,
- (18) a *rough Pythagorean fuzzy near BCC-filter* of X if it is both an upper rough Pythagorean fuzzy near BCC-filter and a lower rough Pythagorean fuzzy near BCC-filter of X ,
- (19) a *rough Pythagorean fuzzy BCC-filter* of X if it is both an upper rough Pythagorean fuzzy BCC-filter and a lower rough Pythagorean fuzzy BCC-filter of X ,

- (20) a *rough Pythagorean fuzzy implicative BCC-filter* of X if it is both an upper rough Pythagorean fuzzy implicative BCC-filter and a lower rough Pythagorean fuzzy implicative BCC-filter of X ,
- (21) a *rough Pythagorean fuzzy comparative BCC-filter* of X if it is both an upper rough Pythagorean fuzzy comparative BCC-filter and a lower rough Pythagorean fuzzy comparative BCC-filter of X , and
- (22) a *rough Pythagorean fuzzy shift BCC-filter* of X if it is both an upper rough Pythagorean fuzzy shift BCC-filter and a lower rough Pythagorean fuzzy shift BCC-filter of X .
- (23) a *rough Pythagorean fuzzy BCC-ideal* of X if it is both an upper rough Pythagorean fuzzy BCC-ideal and a lower rough Pythagorean fuzzy BCC-ideal of X , and
- (24) a *rough Pythagorean fuzzy strong BCC-ideal* of X if it is both an upper rough Pythagorean fuzzy strong BCC-ideal and a lower rough Pythagorean fuzzy strong BCC-ideal of X .

Definition 4.1.3 Let ρ be an equivalence relation on X and $P = (\mu_P, \nu_P)$ a Pythagorean fuzzy sets in X . Then a rough Pythagorean fuzzy set P in X is called *constant rough Pythagorean fuzzy set* in X if their membership functions $\bar{\mu}_P, \underline{\mu}_P$ and non-membership functions $\bar{\nu}_P, \underline{\nu}_P$ are constant.

It is simple to verify the generalizations of rough Pythagorean fuzzy sets in BCC-algebras. As a result, we obtain the diagram of the generalization of rough Pythagorean fuzzy sets in BCC-algebras, which is shown in Figures 3, 4, and 5.

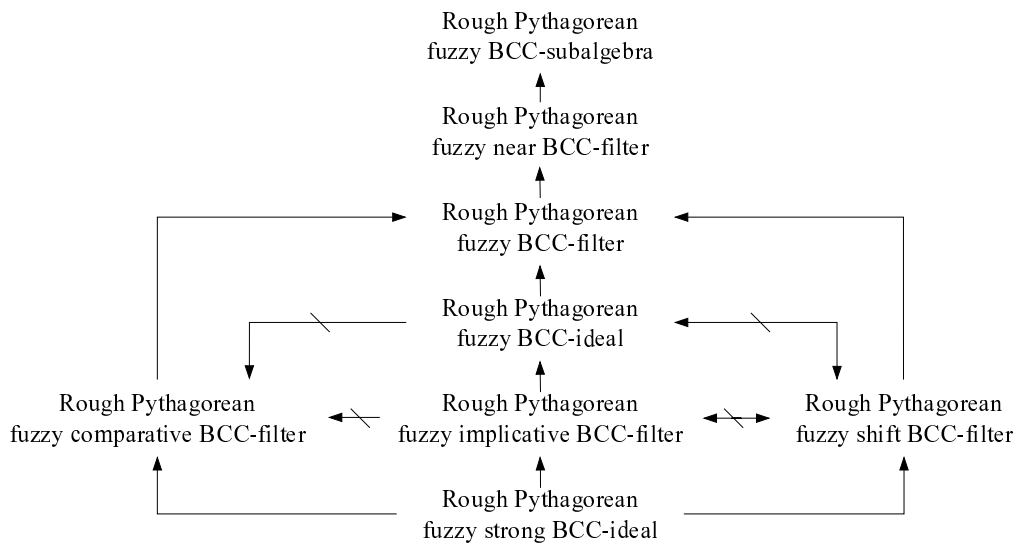

Figure 3: Rough Pythagorean fuzzy sets in BCC-algebras

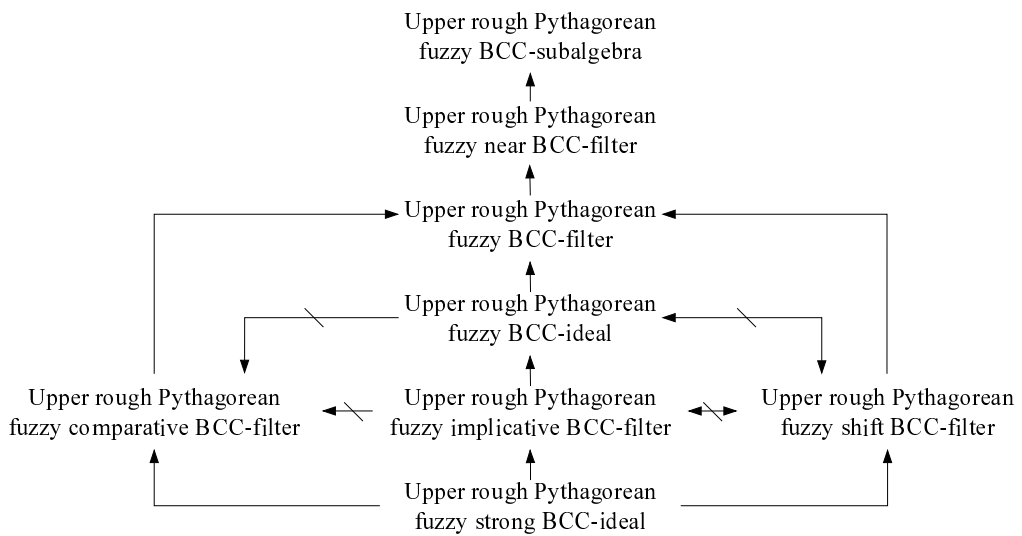

Figure 4: Upper rough Pythagorean fuzzy sets in BCC-algebras

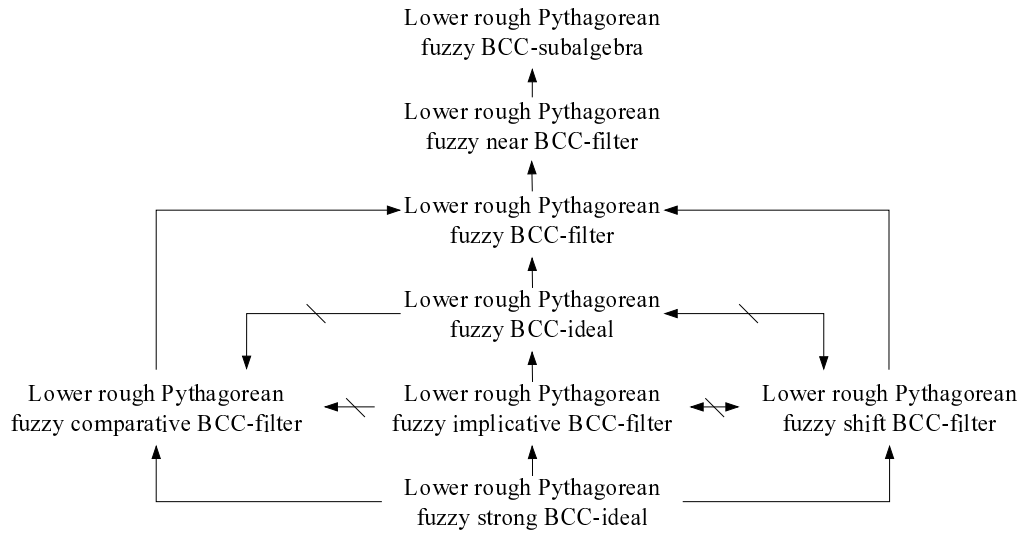

Figure 5: Lower rough Pythagorean fuzzy sets in BCC-algebras

Theorem 4.1.4 *Let ρ be an equivalence relation (congruence relation) on X and $P = (\mu_P, \nu_P)$ a Pythagorean fuzzy sets in X . If P is a Pythagorean fuzzy strong BCC-ideal of X , then P is a rough Pythagorean fuzzy strong BCC-ideal of X .*

Proof. Let P be a Pythagorean fuzzy strong BCC-ideal of X . Then it is constant. For all $x, y \in X$, $\mu_P(x) = \mu_P(y)$ and $\nu_P(x) = \nu_P(y)$. Let $a, b \in X$. Then

$$\begin{aligned}\bar{\mu}_P(a) &= \sup_{x \in (a)_\rho} \{\mu_P(x)\} = \sup_{y \in (b)_\rho} \{\mu_P(y)\} = \bar{\mu}_P(b), \\ \bar{\nu}_P(a) &= \inf_{x \in (a)_\rho} \{\nu_P(x)\} = \inf_{y \in (b)_\rho} \{\nu_P(y)\} = \bar{\nu}_P(b), \\ \underline{\mu}_P(a) &= \inf_{x \in (a)_\rho} \{\mu_P(x)\} = \inf_{y \in (b)_\rho} \{\mu_P(y)\} = \underline{\mu}_P(b), \text{ and} \\ \underline{\nu}_P(a) &= \sup_{x \in (a)_\rho} \{\nu_P(x)\} = \sup_{y \in (b)_\rho} \{\nu_P(y)\} = \underline{\nu}_P(b).\end{aligned}$$

So $\rho^+(P)$ and $\rho^-(P)$ are constant. This means that $\rho^+(P)$ and $\rho^-(P)$ are Pythagorean fuzzy strong BCC-ideals of X . Therefore, P is a rough Pythagorean fuzzy strong BCC-ideal of X . \square

The following examples show the relationships between Pythagorean

fuzzy sets in X and rough Pythagorean fuzzy sets in X with ρ is an equivalence relation on X .

Example 4.1.5 Consider a BCC-algebra $X = (X, \cdot, 0)$, where $X = \{0, 1, 2, 3\}$ is defined in the Cayley table below.

\cdot	0	1	2	3
0	0	1	2	3
1	0	0	2	2
2	0	1	0	2
3	0	1	0	0

We define a Pythagorean fuzzy sets $P = (\mu_P, \nu_P)$ in X as follows:

X	0	1	2	3
μ_P	0.7	0.3	0.6	0.6
ν_P	0.1	0.8	0.4	0.4

Then P is a Pythagorean fuzzy BCC-ideal (resp., Pythagorean fuzzy BCC-filter, Pythagorean fuzzy near BCC-filter, and Pythagorean fuzzy BCC-subalgebra) of X . Let

$$\rho = \{(0, 0), (1, 1), (2, 2), (3, 3), (0, 1), (1, 0), (0, 3), (3, 0), (1, 3), (3, 1)\}.$$

Then ρ is an equivalence relation on X . But $\rho^+(P)$ and $\rho^-(P)$ are not Pythagorean fuzzy BCC-ideals (resp., Pythagorean fuzzy BCC-filters, Pythagorean fuzzy near BCC-filters, and Pythagorean fuzzy BCC-subalgebras) of X .

Example 4.1.6 Consider a BCC-algebra $X = (X, \cdot, 0)$, where $X = \{0, 1, 2, 3\}$ is

defined in the Cayley table below.

·	0	1	2	3
0	0	1	2	3
1	0	0	0	0
2	0	1	0	0
3	0	1	2	0

We define a Pythagorean fuzzy set $P = (\mu_P, \nu_P)$ in X as follows:

X	0	1	2	3
μ_P	1	0.4	0.4	0.4
ν_P	0	0.3	0.3	0.3

Then P is a Pythagorean fuzzy implicative BCC-filter of X . Let

$$\rho = \{(0, 0), (1, 1), (2, 2), (3, 3), (0, 1), (1, 0), (2, 3), (3, 2)\}.$$

Then ρ is an equivalence relation on X . But $\rho^+(P)$ is not a Pythagorean fuzzy implicative BCC-filter of X .

Example 4.1.7 Consider a BCC-algebra $X = (X, \cdot, 0)$, where $X = \{0, 1, 2, 3\}$ is defined in the Cayley table below.

·	0	1	2	3
0	0	1	2	3
1	0	0	1	3
2	0	0	0	3
3	0	0	0	0

We define a Pythagorean fuzzy set $P = (\mu_P, \nu_P)$ in X as follows:

X	0	1	2	3
μ_P	0.6	0.6	0.6	0.3
ν_P	0	0	0	0.1

Then P is a Pythagorean fuzzy comparative BCC-filter (resp., Pythagorean fuzzy shift BCC-filter) of X . Let

$$\rho = \{(0, 0), (1, 1), (2, 2), (3, 3), (1, 2), (2, 1), (1, 3), (3, 1), (2, 3), (3, 2)\}.$$

Then ρ is an equivalence relation on X . But $\rho^-(P)$ is not a Pythagorean fuzzy comparative BCC-filter (resp., Pythagorean fuzzy shift BCC-filter) of X .

From Examples 4.1.5, 4.1.6, and 4.1.7, we get the results that if P is a Pythagorean fuzzy BCC-subalgebra (resp., Pythagorean fuzzy near BCC-filter, Pythagorean fuzzy BCC-filter, Pythagorean fuzzy implicative BCC-filter, Pythagorean fuzzy comparative BCC-filter, Pythagorean fuzzy shift BCC-filter, and Pythagorean fuzzy BCC-ideal), then it may not be a rough Pythagorean fuzzy BCC-subalgebra (resp., rough Pythagorean fuzzy near BCC-filter, rough Pythagorean fuzzy BCC-filter, rough Pythagorean fuzzy implicative BCC-filter, rough Pythagorean fuzzy comparative BCC-filter, rough Pythagorean fuzzy shift BCC-filter, and rough Pythagorean fuzzy BCC-ideal).

Example 4.1.8 Consider a BCC-algebra $X = (X, \cdot, 0)$, where $X = \{0, 1, 2, 3\}$ is

defined in the Cayley table below.

\cdot	0	1	2	3
0	0	1	2	3
1	0	0	1	2
2	0	0	0	1
3	0	0	0	0

We define a Pythagorean fuzzy sets $P = (\mu_P, \nu_P)$ in X as follows:

X	0	1	2	3
μ_P	0.8	0.5	0.4	0.5
ν_P	0.2	0.4	0.7	0.4

Then P is not a Pythagorean fuzzy BCC-subalgebra (resp., Pythagorean fuzzy near BCC-filter, Pythagorean fuzzy BCC-filter, and Pythagorean fuzzy BCC-ideal) of X . Let

$$\rho = \{(0, 0), (1, 1), (2, 2), (3, 3), (1, 2), (2, 1), (2, 3), (3, 2), (1, 3), (3, 1)\}.$$

Then ρ is an equivalence relation on X . But $\rho^+(P)$ and $\rho^-(P)$ are Pythagorean fuzzy BCC-subalgebras (resp., Pythagorean fuzzy near BCC-filters, Pythagorean fuzzy BCC-filters, and Pythagorean fuzzy BCC-ideals) of X .

Example 4.1.9 Consider a BCC-algebra $X = (X, \cdot, 0)$, where $X = \{0, 1, 2, 3\}$ is

defined in the Cayley table below.

·	0	1	2	3
0	0	1	2	3
1	0	0	2	3
2	0	0	0	3
3	0	1	2	0

We define a Pythagorean fuzzy set $P = (\mu_P, \nu_P)$ in X as follows:

X	0	1	2	3
μ_P	0.9	0.1	0.2	0.1
ν_P	0.1	0.5	0.4	0.5

Then P is not a Pythagorean fuzzy implicative BCC-filter of X . Let

$$\rho = \{(0, 0), (1, 1), (2, 2), (3, 3), (1, 2), (2, 1), (2, 3), (3, 2), (1, 3), (3, 1)\}.$$

Then ρ is an equivalence relation on X . But $\rho^+(P)$ and $\rho^-(P)$ are Pythagorean fuzzy implicative BCC-filters of X .

Example 4.1.10 By Example 4.1.9, we define a Pythagorean fuzzy set $P = (\mu_P, \nu_P)$ in X as follows:

X	0	1	2	3
μ_P	0.6	0.5	0.4	0.4
ν_P	0.5	0.7	0.8	0.8

Then P is not a Pythagorean fuzzy comparative BCC-filter of X . Let

$$\rho = \{(0, 0), (1, 1), (2, 2), (3, 3), (1, 0), (0, 1), (2, 3), (3, 2)\}.$$

Then ρ is an equivalence relation on X . But $\rho^+(\mathbf{P})$ and $\rho^-(\mathbf{P})$ are Pythagorean fuzzy comparative BCC-filters of X .

Example 4.1.11 Consider a BCC-algebra $X = (X, \cdot, 0)$, where $X = \{0, 1, 2, 3\}$ is defined in the Cayley table below.

\cdot	0	1	2	3
0	0	1	2	3
1	0	0	2	2
2	0	0	0	2
3	0	0	0	0

We define a Pythagorean fuzzy set $\mathbf{P} = (\mu_{\mathbf{P}}, \nu_{\mathbf{P}})$ in X as follows:

X	0	1	2	3
$\mu_{\mathbf{P}}$	0.6	0.5	0.2	0.5
$\nu_{\mathbf{P}}$	0	0.1	0.7	0.1

Then \mathbf{P} is not a Pythagorean fuzzy shift BCC-filter of X . Let

$$\rho = \{(0, 0), (1, 1), (2, 2), (3, 3), (1, 2), (2, 1), (2, 3), (3, 2), (1, 3), (3, 1)\}.$$

Then ρ is an equivalence relation on X . But $\rho^+(\mathbf{P})$ and $\rho^-(\mathbf{P})$ are Pythagorean fuzzy shift BCC-filters of X .

Example 4.1.12 Consider a BCC-algebra $X = (X, \cdot, 0)$, where $X = \{0, 1, 2, 3\}$

is defined in the Cayley table below.

\cdot	0	1	2	3
0	0	1	2	3
1	0	0	0	0
2	0	1	0	0
3	0	1	2	0

We define a Pythagorean fuzzy sets $P = (\mu_P, \nu_P)$ in X as follows:

X	0	1	2	3
μ_P	0.5	0.4	0.3	0.2
ν_P	0.1	0.2	0.3	0.4

Then P is not a Pythagorean fuzzy strong BCC-ideal of X . Let $\rho = \{(0, 0), (1, 1), (2, 2), (3, 3), (0, 1), (1, 0), (0, 2), (2, 0), (0, 3), (3, 0), (1, 2), (2, 1), (2, 3), (3, 2), (1, 3), (3, 1)\}$. Then ρ is an equivalence relation on X . But $\rho^+(P)$ and $\rho^-(P)$ are Pythagorean fuzzy strong BCC-ideals of X .

From Examples 4.1.8, 4.1.9, 4.1.10, 4.1.11, and 4.1.12, we get the results that if P is a rough Pythagorean fuzzy BCC-subalgebra (resp., rough Pythagorean fuzzy near BCC-filter, rough Pythagorean fuzzy BCC-filter, rough Pythagorean fuzzy implicative BCC-filter, rough Pythagorean fuzzy comparative BCC-filter, rough Pythagorean fuzzy shift BCC-filter, rough Pythagorean fuzzy BCC-ideal, and rough Pythagorean fuzzy strong BCC-ideal), then it may not be a Pythagorean fuzzy BCC-subalgebra (resp., Pythagorean fuzzy near BCC-filter, Pythagorean fuzzy BCC-filter, Pythagorean fuzzy shift BCC-filter, Pythagorean fuzzy comparative BCC-filter, Pythagorean fuzzy shift BCC-filter, Pythagorean fuzzy BCC-ideal, and Pythagorean fuzzy strong BCC-ideal).

Example 4.1.13 Consider a BCC-algebra $X = (X, \cdot, 0)$, where $X = \{0, 1, 2, 3\}$

is defined in the Cayley table below.

·	0	1	2	3
0	0	1	2	3
1	0	0	2	3
2	0	1	0	0
3	0	1	2	0

We define a Pythagorean fuzzy sets $P = (\mu_P, \nu_P)$ in X as follows:

X	0	1	2	3
μ_P	1	0.2	0.1	0.2
ν_P	0	0.6	0.9	0.6

Then P is a Pythagorean fuzzy BCC-ideal (resp., Pythagorean fuzzy BCC-filter, Pythagorean fuzzy near BCC-filter, and Pythagorean fuzzy BCC-subalgebra) of X . Let

$$\rho = \{(0, 0), (1, 1), (2, 2), (3, 3), (1, 2), (2, 1)\}.$$

Then ρ is an equivalence relation on X . Thus $\rho^+(P)$ and $\rho^-(P)$ are Pythagorean fuzzy BCC-ideals (resp., Pythagorean fuzzy BCC-filters, Pythagorean fuzzy near BCC-filters, and Pythagorean fuzzy BCC-subalgebras) of X .

Example 4.1.14 Consider a BCC-algebra $X = (X, \cdot, 0)$, where $X = \{0, 1, 2, 3\}$ is defined in the Cayley table below.

·	0	1	2	3
0	0	1	2	3
1	0	0	2	3
2	0	0	0	3
3	0	0	2	0

We define a Pythagorean fuzzy set $P = (\mu_P, \nu_P)$ in X as follows:

X	0	1	2	3
μ_P	0.9	0.3	0.2	0.1
ν_P	0.1	0.3	0.4	0.5

Then P is a Pythagorean fuzzy implicative BCC-filter of X . Let

$$\rho = \{(0, 0), (1, 1), (2, 2), (3, 3), (1, 2), (2, 1), (1, 3), (3, 1), (2, 3), (3, 2)\}.$$

Then ρ is an equivalence relation on X . Thus $\rho^+(P)$ and $\rho^-(P)$ are Pythagorean fuzzy implicative BCC-filters of X .

Example 4.1.15 By Example 4.1.14, we define a Pythagorean fuzzy set $P = (\mu_P, \nu_P)$ in X as follows:

X	0	1	2	3
μ_P	0.6	0.6	0.3	0.1
ν_P	0.5	0.5	0.6	0.7

Then P is a Pythagorean fuzzy comparative BCC-filter of X . Let

$$\rho = \{(0, 0), (1, 1), (2, 2), (3, 3), (2, 3), (3, 2)\}.$$

Then ρ is an equivalence relation on X . Thus $\rho^+(P)$ and $\rho^-(P)$ are Pythagorean fuzzy comparative BCC-filters of X .

Example 4.1.16 By Example 4.1.11, we define a Pythagorean fuzzy set $P = (\mu_P, \nu_P)$ in X as follows:

X	0	1	2	3
μ_P	1	0.5	0.4	0.4
ν_P	0	0.1	0.5	0.5

Then P is a Pythagorean fuzzy shift BCC-filter of X . Let

$$\rho = \{(0, 0), (1, 1), (2, 2), (3, 3), (1, 0), (0, 1)\}.$$

Then ρ is an equivalence relation on X . Thus $\rho^+(P)$ and $\rho^-(P)$ are Pythagorean fuzzy shift BCC-filters of X .

From Examples 4.1.13, 4.1.14, 4.1.15, and 4.1.16, and Theorem 4.1.4, we get the results that P can be a rough Pythagorean fuzzy BCC-subalgebra (resp., rough Pythagorean fuzzy near BCC-filter, rough Pythagorean fuzzy BCC-filter, rough Pythagorean fuzzy implicative BCC-filter, rough Pythagorean fuzzy comparative BCC-filter, rough Pythagorean fuzzy shift BCC-filter, rough Pythagorean fuzzy BCC-ideal, and rough Pythagorean fuzzy strong BCC-ideal) and a Pythagorean fuzzy BCC-subalgebra (resp., Pythagorean fuzzy near BCC-filter, Pythagorean fuzzy BCC-filter, Pythagorean fuzzy implicative BCC-filter, Pythagorean fuzzy comparative BCC-filter, Pythagorean fuzzy shift BCC-filter, Pythagorean fuzzy BCC-ideal, and Pythagorean fuzzy strong BCC-ideal) in the same time.

The following examples show the relationships between Pythagorean fuzzy sets in X and rough Pythagorean fuzzy sets in X with ρ is a congruence relation on X .

Example 4.1.17 Consider a BCC-algebra $X = (X, \cdot, 0)$, where $X = \{0, 1, 2, 3\}$ is defined in the Cayley table below.

\cdot	0	1	2	3
0	0	1	2	3
1	0	0	2	3
2	0	1	0	3
3	0	1	2	0

We define a Pythagorean fuzzy sets $P = (\mu_P, \nu_P)$ in X as follows:

X	0	1	2	3
μ_P	0.8	0.3	0.5	0.5
ν_P	0.2	0.8	0.3	0.3

Then P is a Pythagorean fuzzy BCC-ideal (resp., Pythagorean fuzzy BCC-filter, Pythagorean fuzzy near BCC-filter, and Pythagorean fuzzy BCC-subalgebra) of X . Let

$$\rho = \{(0, 0), (1, 1), (2, 2), (3, 3), (0, 1), (1, 0)\}.$$

Then ρ is a congruence relation on X . But $\rho^-(P)$ is not a Pythagorean fuzzy BCC-ideal (resp., Pythagorean fuzzy BCC-filter, Pythagorean fuzzy near BCC-filter, and Pythagorean fuzzy BCC-subalgebra) of X .

Example 4.1.18 Consider a BCC-algebra $X = (X, \cdot, 0)$, where $X = \{0, 1, 2, 3\}$ is defined in the Cayley table below.

\cdot	0	1	2	3
0	0	1	2	3
1	0	0	2	3
2	0	1	0	3
3	0	1	2	0

We define a Pythagorean fuzzy set $P = (\mu_P, \nu_P)$ in X as follows:

X	0	1	2	3
μ_P	0.7	0.2	0.6	0.6
ν_P	0.3	0.6	0.5	0.5

Then P is a Pythagorean fuzzy implicative BCC-filter (resp., Pythagorean fuzzy

comparative BCC-filter, and Pythagorean fuzzy shift BCC-filter) of X . Let

$$\rho = \{(0, 0), (1, 1), (2, 2), (3, 3), (0, 1), (1, 0)\}.$$

Then ρ is a congruence relation on X . But $\rho^-(P)$ is not a Pythagorean fuzzy shift BCC-filter (resp., Pythagorean fuzzy comparative BCC-filter, and Pythagorean fuzzy shift BCC-filter) of X .

From Examples 4.1.17 and 4.1.18, we get the results that if P is a Pythagorean fuzzy BCC-subalgebra (resp., Pythagorean fuzzy near BCC-filter, Pythagorean fuzzy BCC-filter, Pythagorean fuzzy implicative BCC-filter, Pythagorean fuzzy comparative BCC-filter, Pythagorean fuzzy shift BCC-filter, and Pythagorean fuzzy BCC-ideal), then it may not be a rough Pythagorean fuzzy BCC-subalgebra (resp., rough Pythagorean fuzzy near BCC-filter, rough Pythagorean fuzzy BCC-filter, rough Pythagorean fuzzy implicative BCC-filter, rough Pythagorean fuzzy comparative BCC-filter, rough Pythagorean fuzzy shift BCC-filter, and rough Pythagorean fuzzy BCC-ideal).

Example 4.1.19 Consider a BCC-algebra $X = (X, \cdot, 0)$, where $X = \{0, 1, 2, 3\}$ is defined in the Cayley table below.

\cdot	0	1	2	3
0	0	1	2	3
1	0	0	2	3
2	0	0	0	3
3	0	1	2	0

We define a Pythagorean fuzzy sets $P = (\mu_P, \nu_P)$ in X as follows:

X	0	1	2	3
μ_P	0.5	0.4	0.3	0.2
ν_P	0.1	0.2	0.3	0.4

Then P is not a Pythagorean fuzzy BCC-subalgebra (resp., Pythagorean fuzzy near BCC-filter, Pythagorean fuzzy BCC-ideal, and Pythagorean fuzzy strong BCC-ideal) of X . Let $\rho = \{(0, 0), (1, 1), (2, 2), (3, 3), (0, 1), (1, 0), (0, 2), (2, 0), (0, 3), (3, 0), (1, 2), (2, 1), (2, 3), (3, 2), (1, 3), (3, 1)\}$. Then ρ is a congruence relation on X . But $\rho^+(P)$ and $\rho^-(P)$ are Pythagorean fuzzy BCC-subalgebras (resp., Pythagorean fuzzy near BCC-filters, Pythagorean fuzzy BCC-filters, Pythagorean fuzzy BCC-ideals, and Pythagorean fuzzy strong BCC-ideals) of X .

Example 4.1.20 Consider a BCC-algebra $X = (X, \cdot, 0)$, where $X = \{0, 1, 2, 3\}$ is defined in the Cayley table below.

\cdot	0	1	2	3
0	0	1	2	3
1	0	0	1	3
2	0	0	0	3
3	0	0	0	0

We define a Pythagorean fuzzy set $P = (\mu_P, \nu_P)$ in X as follows:

X	0	1	2	3
μ_P	0.9	0.5	0.5	0.1
ν_P	0.3	0.5	0.5	0.6

Then P is not a Pythagorean fuzzy implicative BCC-filter (resp., Pythagorean

fuzzy comparative BCC-filter) of X . Let

$$\rho = \{(0, 0), (1, 1), (2, 2), (3, 3), (0, 1), (1, 0), (0, 2), (2, 0), (1, 2), (2, 1)\}.$$

Then ρ is a congruence relation on X . But $\rho^-(P)$ and $\rho^-(P)$ are Pythagorean fuzzy implicative BCC-filters (resp., Pythagorean fuzzy comparative BCC-filters) of X .

Example 4.1.21 Consider a BCC-algebra $X = (X, \cdot, 0)$, where $X = \{0, 1, 2, 3\}$ is defined in the Cayley table below.

\cdot	0	1	2	3
0	0	1	2	3
1	0	0	2	3
2	0	0	0	3
3	0	0	0	0

We define a Pythagorean fuzzy set $P = (\mu_P, \nu_P)$ in X as follows:

X	0	1	2	3
μ_P	0.8	0.4	0.2	0.2
ν_P	0.2	0.3	0.6	0.6

Then P is not a Pythagorean fuzzy shift BCC-filter of X . Let

$$\rho = \{(0, 0), (1, 1), (2, 2), (3, 3), (0, 1), (1, 0), (0, 2), (2, 0), (1, 2), (2, 1)\}.$$

Then ρ is a congruence relation on X . But $\rho^+(P)$ and $\rho^-(P)$ are Pythagorean fuzzy shift BCC-filters of X .

From Examples 4.1.19, 4.1.20, and 4.1.21, we get the results that if P is a rough Pythagorean fuzzy BCC-subalgebra (resp., rough Pythagorean fuzzy

near BCC-filter, rough Pythagorean fuzzy BCC-filter, rough Pythagorean fuzzy implicative BCC-filter, rough Pythagorean fuzzy comparative BCC-filter, rough Pythagorean fuzzy shift BCC-filter, rough Pythagorean fuzzy BCC-ideal, and rough Pythagorean fuzzy strong BCC-ideal), then it may not be a Pythagorean fuzzy BCC-subalgebra (resp., Pythagorean fuzzy near BCC-filter, Pythagorean fuzzy BCC-filter, Pythagorean fuzzy implicative BCC-filter, Pythagorean fuzzy comparative BCC-filter, Pythagorean fuzzy shift BCC-filter, Pythagorean fuzzy BCC-ideal, and Pythagorean fuzzy strong BCC-ideal).

Example 4.1.22 Consider a BCC-algebra $X = (X, \cdot, 0)$, where $X = \{0, 1, 2, 3\}$ is defined in the Cayley table below.

\cdot	0	1	2	3
0	0	1	2	3
1	0	0	3	3
2	0	1	0	0
3	0	1	2	0

We define a Pythagorean fuzzy sets $P = (\mu_P, \nu_P)$ in X as follows:

X	0	1	2	3
μ_P	0.9	0.2	0.3	0.3
ν_P	0.2	0.6	0.5	0.5

Then P is a Pythagorean fuzzy BCC-ideal (resp., Pythagorean fuzzy BCC-filter, Pythagorean fuzzy near BCC-filter, and Pythagorean fuzzy BCC-subalgebra) of X . Let

$$\rho = \{(0, 0), (1, 1), (2, 2), (3, 3), (0, 3), (3, 0)\}.$$

Then ρ is a congruence relation on X . Thus $\rho^+(P)$ and $\rho^-(P)$ are Pythagorean fuzzy BCC-ideals (resp., Pythagorean fuzzy BCC-filters, Pythagorean fuzzy near

BCC-filters, and Pythagorean fuzzy BCC-subalgebras) of X .

Example 4.1.23 By Example 4.1.21, we have P is a Pythagorean fuzzy implicative BCC-filter of X and $\rho^+(P), \rho^-(P)$ are Pythagorean fuzzy implicative BCC-filters of X .

Example 4.1.24 Consider a BCC-algebra $X = (X, \cdot, 0)$, where $X = \{0, 1, 2, 3\}$ is defined in the Cayley table below.

\cdot	0	1	2	3
0	0	1	2	3
1	0	0	1	3
2	0	0	0	3
3	0	1	2	0

We define a Pythagorean fuzzy set $P = (\mu_P, \nu_P)$ in X as follows:

X	0	1	2	3
μ_P	0.6	0.6	0.6	0.4
ν_P	0.5	0.5	0.5	0.8

Then P is a Pythagorean fuzzy comparative BCC-filter of X . Let

$$\rho = \{(0, 0), (1, 1), (2, 2), (3, 3), (1, 0), (0, 1), (2, 0), (0, 2), (1, 2), (2, 1)\}.$$

Then ρ is a congruence relation on X . Thus $\rho^+(P)$ and $\rho^-(P)$ are Pythagorean fuzzy comparative BCC-filters of X .

Example 4.1.25 By Example 4.1.24, we define a Pythagorean fuzzy set $P =$

(μ_P, ν_P) in X as follows:

X	0	1	2	3
μ_P	0.8	0.4	0.4	0.2
ν_P	0.3	0.5	0.5	0.7

Then P is a Pythagorean fuzzy shift BCC-filter of X . Let

$$\rho = \{(0, 0), (1, 1), (2, 2), (3, 3), (1, 0), (0, 1), (2, 0), (0, 2), (1, 2), (2, 1)\}.$$

Then ρ is a congruence relation on X . Thus $\rho^+(P)$ and $\rho^-(P)$ are Pythagorean fuzzy shift BCC-filters of X .

From Examples 4.1.22, 4.1.23, 4.1.24, and 4.1.25, we get the results that P can be a rough Pythagorean fuzzy BCC-subalgebra (resp., rough Pythagorean fuzzy near BCC-filter, rough Pythagorean fuzzy BCC-filter, rough Pythagorean fuzzy implicative BCC-filter, rough Pythagorean fuzzy comparative BCC-filter, rough Pythagorean fuzzy shift BCC-filter, rough Pythagorean fuzzy BCC-ideal, and rough Pythagorean fuzzy strong BCC-ideal) and a Pythagorean fuzzy BCC-subalgebra (resp., Pythagorean fuzzy near BCC-filter, Pythagorean fuzzy BCC-filter, Pythagorean fuzzy implicative BCC-filter, Pythagorean fuzzy comparative BCC-filter, Pythagorean fuzzy shift BCC-filter, Pythagorean fuzzy BCC-ideal, and Pythagorean fuzzy strong BCC-ideal) in the same time.

4.2 t -Level subsets of rough Pythagorean fuzzy sets

In this section, we shall discuss the relationships between rough Pythagorean fuzzy BCC-subalgebras (rough Pythagorean fuzzy near BCC-filters, rough Pythagorean fuzzy BCC-filters, rough Pythagorean fuzzy BCC-ideals, and rough Pythagorean fuzzy strong BCC-ideals) of BCC-algebras and their t -level subsets.

The following lemma shows the relationships between t -level subsets of approximations and approximations of t -level subsets.

Lemma 4.2.1 *Let ρ be a congruence relation on X and $t \in [0, 1]$. Then the following statements hold:*

$$(1) U(\bar{\mu}_P, t) = \rho^-(U(\mu_P, t)),$$

$$(2) U^+(\bar{\mu}_P, t) = \rho^-(U^+(\mu_P, t)),$$

$$(3) L(\bar{\nu}_P, t) = \rho^+(L(\nu_P, t)),$$

$$(4) L^-(\bar{\nu}_P, t) = \rho^+(L^-(\nu_P, t)),$$

$$(5) U(\underline{\mu}_P, t) = \rho^+(U(\mu_P, t)),$$

$$(6) U^+(\underline{\mu}_P, t) = \rho^+(U^+(\mu_P, t)),$$

$$(7) L(\underline{\nu}_P, t) = \rho^-(L(\nu_P, t)), \text{ and}$$

$$(8) L^-(\underline{\nu}_P, t) = \rho^-(L^-(\nu_P, t)).$$

Proof. (1) Let $x \in X$. Then

$$x \in U(\bar{\mu}_P, t) \Leftrightarrow \bar{\mu}_P(x) \geq t \quad (\text{Definition 3.4.1})$$

$$\Leftrightarrow \sup_{a \in (x)_\rho} \{\mu_P(a)\} \geq t \quad (\text{Definition 3.3.1})$$

$$\Leftrightarrow \exists a \in (x)_\rho, \mu_P(a) \geq t$$

$$\Leftrightarrow \exists a \in (x)_\rho \cap U(\mu_P, t) \neq \emptyset \quad (\text{Definition 3.4.1})$$

$$\Leftrightarrow x \in \rho^-(U(\mu_P, t)). \quad (\text{Definition 2.0.14})$$

(2) Let $x \in X$. Then

$$x \in U^+(\bar{\mu}_P, t) \Leftrightarrow \bar{\mu}_P(x) > t \quad (\text{Definition 3.4.1})$$

$$\Leftrightarrow \sup_{a \in (x)_\rho} \{\mu_P(a)\} > t \quad (\text{Definition 3.3.1})$$

$$\Leftrightarrow \exists a \in (x)_\rho, \mu_P(a) > t$$

$$\Leftrightarrow \exists a \in (x)_\rho \cap U^+(\mu_P, t) \neq \emptyset \quad (\text{Definition 3.4.1})$$

$$\Leftrightarrow x \in \rho^-(U^+(\mu_P, t)). \quad (\text{Definition 2.0.14})$$

(3) Let $x \in X$. Then

$$x \in L(\bar{\nu}_P, t) \Leftrightarrow \bar{\nu}_P(x) \leq t \quad (\text{Definition 3.4.1})$$

$$\Leftrightarrow \inf_{a \in (x)_\rho} \{\nu_P(a)\} \leq t \quad (\text{Definition 3.3.1})$$

$$\Leftrightarrow \forall a \in (x)_\rho, \nu_P(a) \leq t$$

$$\Leftrightarrow \forall a \in (x)_\rho, a \in L(\nu_P, t) \quad (\text{Definition 3.4.1})$$

$$\Leftrightarrow (x)_\rho \subseteq L(\nu_P, t)$$

$$\Leftrightarrow x \in \rho^+(L(\nu_P, t)). \quad (\text{Definition 2.0.14})$$

(4) Let $x \in X$. Then

$$x \in L^-(\bar{\nu}_P, t) \Leftrightarrow \bar{\nu}_P(x) < t \quad (\text{Definition 3.4.1})$$

$$\Leftrightarrow \inf_{a \in (x)_\rho} \{\nu_P(a)\} < t \quad (\text{Definition 3.3.1})$$

$$\Leftrightarrow \forall a \in (x)_\rho, \nu_P(a) < t$$

$$\Leftrightarrow \forall a \in (x)_\rho, a \in L^-(\nu_P, t) \quad (\text{Definition 3.4.1})$$

$$\Leftrightarrow (x)_\rho \subseteq L^-(\nu_P, t)$$

$$\Leftrightarrow x \in \rho^+(L^-(\nu_P, t)). \quad (\text{Definition 2.0.14})$$

(5) Let $x \in X$. Then

$$x \in U(\underline{\mu}_P, t) \Leftrightarrow \underline{\mu}_P(x) \geq t \quad (\text{Definition 3.4.1})$$

$$\Leftrightarrow \inf_{a \in (x)_\rho} \{\mu_P(a)\} \geq t \quad (\text{Definition 3.3.1})$$

$$\Leftrightarrow \forall a \in (x)_\rho, \mu_P(a) \geq t$$

$$\Leftrightarrow \forall a \in (x)_\rho, a \in U(\mu_P, t) \quad (\text{Definition 3.4.1})$$

$$\Leftrightarrow (x)_\rho \subseteq U(\mu_P, t)$$

$$\Leftrightarrow x \in \rho^+(U(\mu_P, t)). \quad (\text{Definition 2.0.14})$$

(6) Let $x \in X$. Then

$$x \in U^+(\underline{\mu}_P, t) \Leftrightarrow \underline{\mu}_P(x) > t \quad (\text{Definition 3.4.1})$$

$$\Leftrightarrow \inf_{a \in (x)_\rho} \{\mu_P(a)\} > t \quad (\text{Definition 3.3.1})$$

$$\Leftrightarrow \forall a \in (x)_\rho, \mu_P(a) > t$$

$$\Leftrightarrow \forall a \in (x)_\rho, a \in U^+(\mu_P, t) \quad (\text{Definition 3.4.1})$$

$$\Leftrightarrow (x)_\rho \subseteq U^+(\mu_P, t)$$

$$\Leftrightarrow x \in \rho^+(U^+(\mu_P, t)). \quad (\text{Definition 2.0.14})$$

(7) Let $x \in X$. Then

$$x \in L(\underline{\nu}_P, t) \Leftrightarrow \underline{\nu}_P(x) \leq t \quad (\text{Definition 3.4.1})$$

$$\Leftrightarrow \sup_{a \in (x)_\rho} \{\nu_P(a)\} \leq t \quad (\text{Definition 3.3.1})$$

$$\Leftrightarrow \exists a \in (x)_\rho, \nu_P(a) \leq t$$

$$\Leftrightarrow \exists a \in (x)_\rho \cap L(\nu_P, t) \neq \emptyset \quad (\text{Definition 3.4.1})$$

$$\Leftrightarrow x \in \rho^-(L(\nu_P, t)). \quad (\text{Definition 2.0.14})$$

(8) Let $x \in X$. Then

$$x \in L^-(\underline{\nu}_P, t) \Leftrightarrow \underline{\nu}_P(x) < t \quad (\text{Definition 3.4.1})$$

$$\Leftrightarrow \sup_{a \in (x)_\rho} \{\nu_P(a)\} < t \quad (\text{Definition 3.3.1})$$

$$\Leftrightarrow \exists a \in (x)_\rho, \nu_P(a) < t$$

$$\Leftrightarrow \exists a \in (x)_\rho \cap L^-(\nu_P, t) \neq \emptyset \quad (\text{Definition 3.4.1})$$

$$\Leftrightarrow x \in \rho^-(L^-(\nu_P, t)). \quad (\text{Definition 2.0.14})$$

□

The following theorems show the relationships between rough Pythagorean fuzzy sets and their t -level subsets.

Theorem 4.2.2 *Let ρ be a congruence relation on X . Then P is an upper rough Pythagorean fuzzy BCC-subalgebra of X if and only if $U(\mu_P, t)$ and $L(\nu_P, t)$ are, if the sets are nonempty, an upper rough BCC-subalgebra and a lower rough BCC-subalgebra of X for every $t \in [0, 1]$, respectively.*

Proof. It is straightforward by Theorem 3.4.2 and Lemmas 4.2.1 (1) and (3). □

Theorem 4.2.3 *Let ρ be a congruence relation on X . Then P is an upper rough Pythagorean fuzzy BCC-subalgebra of X if and only if $U^+(\mu_P, t)$ and $L^-(\nu_P, t)$ are, if the sets are nonempty, an upper rough BCC-subalgebra and a lower rough BCC-subalgebra of X for every $t \in [0, 1]$, respectively.*

Proof. It is straightforward by Theorem 3.4.3 and Lemmas 4.2.1 (2) and (4). □

Theorem 4.2.4 *Let ρ be a congruence relation on X . Then P is an upper rough Pythagorean fuzzy near BCC-filter of X if and only if $U(\mu_P, t)$ and $L(\nu_P, t)$ are, if the sets are nonempty, an upper rough near BCC-filter and a lower rough near BCC-filter of X for every $t \in [0, 1]$, respectively.*

Proof. It is straightforward by Theorem 3.4.4 and Lemmas 4.2.1 (1) and (3). \square

Theorem 4.2.5 *Let ρ be a congruence relation on X . Then P is an upper rough Pythagorean fuzzy near BCC-filter of X if and only if $U^+(\mu_P, t)$ and $L^-(\nu_P, t)$ are, if the sets are nonempty, an upper rough near BCC-filter and a lower rough near BCC-filter of X for every $t \in [0, 1]$, respectively.*

Proof. It is straightforward by Theorem 3.4.4 and Lemmas 4.2.1 (1) and (3). \square

Theorem 4.2.6 *Let ρ be a congruence relation on X . Then P is an upper rough Pythagorean fuzzy BCC-filter of X if and only if $U(\mu_P, t)$ and $L(\nu_P, t)$ are, if the sets are nonempty, an upper rough BCC-filter and a lower rough BCC-filter of X for every $t \in [0, 1]$, respectively.*

Proof. It is straightforward by Theorem 3.4.6 and Lemmas 4.2.1 (1) and (3). \square

Theorem 4.2.7 *Let ρ be a congruence relation on X . Then P is an upper rough Pythagorean fuzzy BCC-filter of X if and only if $U^+(\mu_P, t)$ and $L^-(\nu_P, t)$ are, if the sets are nonempty, an upper rough BCC-filter and a lower rough BCC-filter of X for every $t \in [0, 1]$, respectively.*

Proof. It is straightforward by Theorem 3.4.7 and Lemmas 4.2.1 (2) and (4). \square

Theorem 4.2.8 *Let ρ be a congruence relation on X . Then P is an upper rough Pythagorean fuzzy implicative BCC-filter of X if and only if $U(\mu_P, t)$ and $L(\nu_P, t)$ are, if the sets are nonempty, an upper rough implicative BCC-filter and a lower rough implicative BCC-filter of X for every $t \in [0, 1]$, respectively.*

Proof. It is straightforward by Theorem 3.4.8 and Lemmas 4.2.1 (1) and (3). \square

Theorem 4.2.9 *Let ρ be a congruence relation on X . Then P is an upper rough Pythagorean fuzzy implicative BCC-filter of X if and only if $U^+(\mu_P, t)$ and*

$L^-(\nu_P, t)$ are, if the sets are nonempty, an upper rough implicative BCC-filter and a lower rough implicative BCC-filter of X for every $t \in [0, 1]$, respectively.

Proof. It is straightforward by Theorem 3.4.9 and Lemmas 4.2.1 (2) and (4). \square

Theorem 4.2.10 Let ρ be a congruence relation on X . Then P is an upper rough Pythagorean fuzzy comparative BCC-filter of X if and only if $U(\mu_P, t)$ and $L(\nu_P, t)$ are, if the sets are nonempty, an upper rough comparative BCC-filter and a lower rough comparative BCC-filter of X for every $t \in [0, 1]$, respectively.

Proof. It is straightforward by Theorem 3.4.10 and Lemmas 4.2.1 (1) and (3). \square

Theorem 4.2.11 Let ρ be a congruence relation on X . Then P is an upper rough Pythagorean fuzzy comparative BCC-filter of X if and only if $U^+(\mu_P, t)$ and $L^-(\nu_P, t)$ are, if the sets are nonempty, an upper rough comparative BCC-filter and a lower rough comparative BCC-filter of X for every $t \in [0, 1]$, respectively.

Proof. It is straightforward by Theorem 3.4.11 and Lemmas 4.2.1 (2) and (4). \square

Theorem 4.2.12 Let ρ be a congruence relation on X . Then P is an upper rough Pythagorean fuzzy shift BCC-filter of X if and only if $U(\mu_P, t)$ and $L(\nu_P, t)$ are, if the sets are nonempty, an upper rough shift BCC-filter and a lower rough shift BCC-filter of X for every $t \in [0, 1]$, respectively.

Proof. It is straightforward by Theorem 3.4.12 and Lemmas 4.2.1 (1) and (3). \square

Theorem 4.2.13 Let ρ be a congruence relation on X . Then P is an upper rough Pythagorean fuzzy shift BCC-filter of X if and only if $U^+(\mu_P, t)$ and $L^-(\nu_P, t)$ are, if the sets are nonempty, an upper rough shift BCC-filter and a lower rough shift BCC-filter of X for every $t \in [0, 1]$, respectively.

Proof. It is straightforward by Theorem 3.4.13 and Lemmas 4.2.1 (2) and (4). \square

Theorem 4.2.14 *Let ρ be a congruence relation on X . Then P is an upper rough Pythagorean fuzzy BCC-ideal of X if and only if $U(\mu_P, t)$ and $L(\nu_P, t)$ are, if the sets are nonempty, an upper rough BCC-ideal and a lower rough BCC-ideal of X for every $t \in [0, 1]$, respectively.*

Proof. It is straightforward by Theorem 3.4.14 and Lemmas 4.2.1 (1) and (3). \square

Theorem 4.2.15 *Let ρ be a congruence relation on X . Then P is an upper rough Pythagorean fuzzy BCC-ideal of X if and only if $U^+(\mu_P, t)$ and $L^-(\nu_P, t)$ are, if the sets are nonempty, an upper rough BCC-ideal and a lower rough BCC-ideal of X for every $t \in [0, 1]$, respectively.*

Proof. It is straightforward by Theorem 3.4.15 and Lemmas 4.2.1 (2) and (4). \square

Theorem 4.2.16 *Let ρ be a congruence relation on X . Then P is an upper rough Pythagorean fuzzy strong BCC-ideal of X if and only if $U(\mu_P, t)$ and $L(\nu_P, t)$ are, if the sets are nonempty, an upper rough strong BCC-ideal and a lower rough strong BCC-ideal of X for every $t \in [0, 1]$, respectively.*

Proof. It is straightforward by Theorem 3.4.16 and Lemmas 4.2.1 (1) and (3). \square

Theorem 4.2.17 *Let ρ be a congruence relation on X . Then P is an upper rough Pythagorean fuzzy strong BCC-ideal of X if and only if $U^+(\mu_P, t)$ and $L^-(\nu_P, t)$ are, if the sets are nonempty, an upper rough strong BCC-ideal and a lower rough strong BCC-ideal of X for every $t \in [0, 1]$, respectively.*

Proof. It is straightforward by Theorem 3.4.17 and Lemmas 4.2.1 (2) and (4). \square

Theorem 4.2.18 *Let ρ be a congruence relation on X . Then P is a lower rough Pythagorean fuzzy BCC-subalgebra of X if and only if $U(\mu_P, t)$ and $L(\nu_P, t)$ are, if the sets are nonempty, an upper rough BCC-subalgebra and a lower rough BCC-subalgebra of X for every $t \in [0, 1]$, respectively.*

Proof. It is straightforward by Theorem 3.4.2 and Lemmas 4.2.1 (5) and (7). \square

Theorem 4.2.19 *Let ρ be a congruence relation on X . Then P is a lower rough Pythagorean fuzzy BCC-subalgebra of X if and only if $U^+(\mu_P, t)$ and $L^-(\nu_P, t)$ are, if the sets are nonempty, an upper rough BCC-subalgebra and a lower rough BCC-subalgebra of X for every $t \in [0, 1]$, respectively.*

Proof. It is straightforward by Theorem 3.4.3 and Lemmas 4.2.1 (6) and (8). \square

Theorem 4.2.20 *Let ρ be a congruence relation on X . Then P is a lower rough Pythagorean fuzzy near BCC-filter of X if and only if $U(\mu_P, t)$ and $L(\nu_P, t)$ are, if the sets are nonempty, an upper rough near BCC-filter and a lower rough near BCC-filter of X for every $t \in [0, 1]$, respectively.*

Proof. It is straightforward by Theorem 3.4.4 and Lemmas 4.2.1 (5) and (7). \square

Theorem 4.2.21 *Let ρ be a congruence relation on X . Then P is a lower rough Pythagorean fuzzy near BCC-filter of X if and only if $U^+(\mu_P, t)$ and $L^-(\nu_P, t)$ are, if the sets are nonempty, an upper rough near BCC-filter and a lower rough near BCC-filter of X for every $t \in [0, 1]$, respectively.*

Proof. It is straightforward by Theorem 3.4.5 and Lemmas 4.2.1 (6) and (8). \square

Theorem 4.2.22 *Let ρ be a congruence relation on X . Then P is a lower rough Pythagorean fuzzy BCC-filter of X if and only if $U(\mu_P, t)$ and $L(\nu_P, t)$ are, if the sets are nonempty, an upper rough BCC-filter and a lower rough BCC-filter of X for every $t \in [0, 1]$, respectively.*

Proof. It is straightforward by Theorem 3.4.6 and Lemmas 4.2.1 (5) and (7). \square

Theorem 4.2.23 *Let ρ be a congruence relation on X . Then P is a lower rough Pythagorean fuzzy BCC-filter of X if and only if $U^+(\mu_P, t)$ and $L^-(\nu_P, t)$ are, if*

the sets are nonempty, an upper rough BCC-filter and a lower rough BCC-filter of X for every $t \in [0, 1]$, respectively.

Proof. It is straightforward by Theorem 3.4.7 and Lemmas 4.2.1 (6) and (8). \square

Theorem 4.2.24 *Let ρ be a congruence relation on X . Then P is a lower rough Pythagorean fuzzy implicative BCC-filter of X if and only if $U(\mu_P, t)$ and $L(\nu_P, t)$ are, if the sets are nonempty, an upper rough implicative BCC-filter and a lower rough implicative BCC-filter of X for every $t \in [0, 1]$, respectively.*

Proof. It is straightforward by Theorem 3.4.8 and Lemmas 4.2.1 (5) and (7). \square

Theorem 4.2.25 *Let ρ be a congruence relation on X . Then P is a lower rough Pythagorean fuzzy implicative BCC-filter of X if and only if $U^+(\mu_P, t)$ and $L^-(\nu_P, t)$ are, if the sets are nonempty, an upper rough implicative BCC-filter and a lower rough implicative BCC-filter of X for every $t \in [0, 1]$, respectively.*

Proof. It is straightforward by Theorem 3.4.9 and Lemmas 4.2.1 (6) and (8). \square

Theorem 4.2.26 *Let ρ be a congruence relation on X . Then P is a lower rough Pythagorean fuzzy comparative BCC-filter of X if and only if $U(\mu_P, t)$ and $L(\nu_P, t)$ are, if the sets are nonempty, an upper rough comparative BCC-filter and a lower rough comparative BCC-filter of X for every $t \in [0, 1]$, respectively.*

Proof. It is straightforward by Theorem 3.4.10 and Lemmas 4.2.1 (5) and (7). \square

Theorem 4.2.27 *Let ρ be a congruence relation on X . Then P is a lower rough Pythagorean fuzzy comparative BCC-filter of X if and only if $U^+(\mu_P, t)$ and $L^-(\nu_P, t)$ are, if the sets are nonempty, an upper rough comparative BCC-filter and a lower rough comparative BCC-filter of X for every $t \in [0, 1]$, respectively.*

Proof. It is straightforward by Theorem 3.4.11 and Lemmas 4.2.1 (6) and (8). \square

Theorem 4.2.28 *Let ρ be a congruence relation on X . Then P is a lower rough Pythagorean fuzzy shift BCC-filter of X if and only if $U(\mu_P, t)$ and $L(\nu_P, t)$ are, if the sets are nonempty, an upper rough shift BCC-filter and a lower rough shift BCC-filter of X for every $t \in [0, 1]$, respectively.*

Proof. It is straightforward by Theorem 3.4.12 and Lemmas 4.2.1 (5) and (7). \square

Theorem 4.2.29 *Let ρ be a congruence relation on X . Then P is a lower rough Pythagorean fuzzy shift BCC-filter of X if and only if $U^+(\mu_P, t)$ and $L^-(\nu_P, t)$ are, if the sets are nonempty, an upper rough shift BCC-filter and a lower rough shift BCC-filter of X for every $t \in [0, 1]$, respectively.*

Proof. It is straightforward by Theorem 3.4.13 and Lemmas 4.2.1 (6) and (8). \square

Theorem 4.2.30 *Let ρ be a congruence relation on X . Then P is a lower rough Pythagorean fuzzy BCC-ideal of X if and only if $U(\mu_P, t)$ and $L(\nu_P, t)$ are, if the sets are nonempty, an upper rough BCC-ideal and a lower rough BCC-ideal of X for every $t \in [0, 1]$, respectively.*

Proof. It is straightforward by Theorem 3.4.14 and Lemmas 4.2.1 (5) and (7). \square

Theorem 4.2.31 *Let ρ be a congruence relation on X . Then P is a lower rough Pythagorean fuzzy BCC-ideal of X if and only if $U^+(\mu_P, t)$ and $L^-(\nu_P, t)$ are, if the sets are nonempty, an upper rough BCC-ideal and a lower rough BCC-ideal of X for every $t \in [0, 1]$, respectively.*

Proof. It is straightforward by Theorem 3.4.15 and Lemmas 4.2.1 (6) and (8). \square

Theorem 4.2.32 *Let ρ be a congruence relation on X . Then P is a lower rough Pythagorean fuzzy strong BCC-ideal of X if and only if $U(\mu_P, t)$ and $L(\nu_P, t)$ are, if the sets are nonempty, an upper rough strong BCC-ideal and a lower rough strong BCC-ideal of X for every $t \in [0, 1]$, respectively.*

Proof. It is straightforward by Theorem 3.4.16 and Lemmas 4.2.1 (5) and (7). \square

Theorem 4.2.33 *Let ρ be a congruence relation on X . Then P is a lower rough Pythagorean fuzzy strong BCC-ideal of X if and only if $U^+(\mu_P, t)$ and $L^-(\nu_P, t)$ are, if the sets are nonempty, an upper rough strong BCC-ideal and a lower rough strong BCC-ideal of X for every $t \in [0, 1]$, respectively.*

Proof. It is straightforward by Theorem 3.4.17 and Lemmas 4.2.1 (6) and (8). \square

Theorem 4.2.34 *Let ρ be a congruence relation on X . Then P is a rough Pythagorean fuzzy BCC-subalgebra (resp., rough Pythagorean fuzzy near BCC-filter, rough Pythagorean fuzzy BCC-filter, rough Pythagorean fuzzy BCC-ideal, and rough Pythagorean fuzzy strong BCC-ideal) of X if and only if $U(\mu_P, t)$ and $L(\nu_P, t)$ are, if the sets are nonempty, rough BCC-subalgebras (resp., rough near BCC-filters, rough BCC-filters, rough BCC-ideals, and rough strong BCC-ideals) of X for every $t \in [0, 1]$.*

Proof. It is straightforward by Theorems 4.2.2 (resp., Theorems 4.2.4, 4.2.6, 4.2.14, 4.2.16) and 4.2.18 (resp., Theorems 4.2.20, 4.2.22, 4.2.30, 4.2.32). \square

Theorem 4.2.35 *Let ρ be a congruence relation on X . Then P is a rough Pythagorean fuzzy BCC-subalgebra (resp., rough Pythagorean fuzzy near BCC-filter, rough Pythagorean fuzzy BCC-filter, rough Pythagorean fuzzy BCC-ideal, and rough Pythagorean fuzzy strong BCC-ideal) of X if and only if $U^+(\mu_P, t)$ and $L^-(\nu_P, t)$ are, if the sets are nonempty, rough BCC-subalgebras (resp., rough near BCC-filters, rough BCC-filters, rough BCC-ideals, and rough strong BCC-ideals) of X for every $t \in [0, 1]$.*

Proof. It is straightforward by Theorems 4.2.3 (resp., Theorems 4.2.5, 4.2.7, 4.2.15, 4.2.17) and 4.2.19 (resp., Theorems 4.2.21, 4.2.23, 4.2.31, 4.2.33). \square

Theorem 4.2.36 *Let ρ be a congruence relation on X . Then P is a rough Pythagorean fuzzy implicative BCC-filter (resp., rough Pythagorean fuzzy comparative BCC-filter, and rough Pythagorean fuzzy shift BCC-filter) of X if and only if $U(\mu_P, t)$ and $L(\nu_P, t)$ are, if the sets are nonempty, rough implicative BCC-filters (resp., rough comparative BCC-filters, and rough shift BCC-filters) of X for every $t \in [0, 1]$.*

Proof. It is straightforward by Theorems 4.2.8 (resp., Theorems 4.2.10, 4.2.12) and 4.2.24 (resp., Theorems 4.2.26, 4.2.28). \square

Theorem 4.2.37 *Let ρ be a congruence relation on X . Then P is a rough Pythagorean fuzzy implicative BCC-filter (resp., rough Pythagorean fuzzy comparative BCC-filter, and rough Pythagorean fuzzy shift BCC-filter) of X if and only if $U^+(\mu_P, t)$ and $L^-(\nu_P, t)$ are, if the sets are nonempty, rough implicative BCC-filters (resp., rough comparative BCC-filters, and rough shift BCC-filters) of X for every $t \in [0, 1]$.*

Proof. It is straightforward by Theorems 4.2.9 (resp., Theorems 4.2.11, 4.2.13) and 4.2.25 (resp., Theorems 4.2.27, 4.2.29). \square

CHAPTER V

PYTHAGOREAN FUZZY SOFT SETS

5.1 Pythagorean fuzzy soft sets over BCC-algebras

Definition 5.1.1 A Pythagorean fuzzy soft set (\tilde{P}, A) over X is called a *Pythagorean fuzzy soft BCC-subalgebra* based on the element $a \in A$ (we shortly call an *a-Pythagorean fuzzy soft BCC-subalgebra*) of X if a Pythagorean fuzzy set $\tilde{P}[a]$ in X is a Pythagorean fuzzy BCC-subalgebra. If (\tilde{P}, A) is an *a-Pythagorean fuzzy soft BCC-subalgebra* of X for all $a \in A$, we say that (\tilde{P}, A) is a *Pythagorean fuzzy soft BCC-subalgebra* of X .

The proof of the following theorem can be verified easily.

Theorem 5.1.2 *If (\tilde{P}, A) is a Pythagorean fuzzy soft BCC-subalgebra of X and $\emptyset \neq B \subseteq A$, then $(\tilde{P}|_B, B)$ is a Pythagorean fuzzy soft BCC-subalgebra of X .*

The following example shows that there exists a nonempty subset B of A such that $(\tilde{P}|_B, B)$ is a Pythagorean fuzzy soft BCC-subalgebra of X , but (\tilde{P}, A) is not a Pythagorean fuzzy soft BCC-subalgebra of X .

Example 5.1.3 By Example 2.0.20, we have $\tilde{P}[\text{beauty}]$ is a Pythagorean fuzzy BCC-subalgebra of X . But $\tilde{P}[\text{identity}]$ and $\tilde{P}[\text{skill}]$ are not Pythagorean fuzzy BCC-subalgebras of X . Indeed, $\nu_{\tilde{P}[\text{identity}]}(1 \cdot 1) = \nu_{\tilde{P}[\text{identity}]}(0) = 0.5 \not\leq 0.3 = \min\{0.3, 0.3\} = \min\{\nu_{\tilde{P}[\text{identity}]}(1), \nu_{\tilde{P}[\text{identity}]}(1)\}$ and

$$\mu_{\tilde{P}[\text{skill}]}(2 \cdot 2) = \mu_{\tilde{P}[\text{skill}]}(0) = 0.3 \not\leq 0.5 = \min\{0.5, 0.5\} = \min\{\mu_{\tilde{P}[\text{skill}]}(2), \mu_{\tilde{P}[\text{skill}]}(2)\}.$$

Hence, (\tilde{P}, A) is not a Pythagorean fuzzy soft BCC-subalgebra over X . We take

$$B = \{\text{beauty}\}.$$

Thus $(\tilde{P}|_B, B)$ is a Pythagorean fuzzy soft BCC-subalgebra of X .

Definition 5.1.4 A Pythagorean fuzzy soft set (\tilde{P}, A) over X is called a *Pythagorean fuzzy soft near BCC-filter* based on $a \in A$ (we shortly call an *a-Pythagorean fuzzy soft near BCC-filter*) of X if a Pythagorean fuzzy set $\tilde{P}[a]$ in X is a Pythagorean fuzzy near BCC-filter. If (\tilde{P}, A) is an *a-Pythagorean fuzzy soft near BCC-filter* of X for all $a \in A$, we say that (\tilde{P}, A) is a *Pythagorean fuzzy soft near BCC-filter* of X .

The proof of the following theorem can be verified easily.

Theorem 5.1.5 *If (\tilde{P}, A) is a Pythagorean fuzzy soft near BCC-filter of X and $\emptyset \neq B \subseteq A$, then $(\tilde{P}|_B, B)$ is a Pythagorean fuzzy soft near BCC-filter of X .*

From Figure 1, we have the following theorem.

Theorem 5.1.6 *Every a-Pythagorean fuzzy soft near BCC-filter of X is an a-Pythagorean fuzzy soft BCC-subalgebra. Moreover, every Pythagorean fuzzy soft near BCC-filter of X is a Pythagorean fuzzy soft BCC-subalgebra.*

The following example shows that the converse of Theorem 5.1.6 is not true.

Example 5.1.7 Let X be a set of four drinks, that is,

$$X = \{\text{Chocolate, Thai tea, Latte, Espresso}\}.$$

Define binary operation \cdot on X as the following Cayley table:

\cdot	Chocolate	Thai tea	Latte	Espresso
Chocolate	Chocolate	Thai tea	Latte	Espresso
Thai tea	Chocolate	Chocolate	Thai tea	Espresso
Latte	Chocolate	Chocolate	Chocolate	Espresso
Espresso	Chocolate	Thai tea	Thai tea	Chocolate

Then $X = (X, \cdot, \text{Chocolate})$ is a BCC-algebra. Let (\tilde{P}, A) be a Pythagorean fuzzy soft set over X where

$$A := \{\text{child, teen, adult}\}$$

with $\tilde{P}[\text{child}]$, $\tilde{P}[\text{teen}]$, and $\tilde{P}[\text{adult}]$ are Pythagorean fuzzy sets in X defined as follows:

\tilde{P}	Chocolate	Thai tea	Latte	Espresso
child	(1, 0)	(0.3, 0.4)	(0.9, 0.2)	(0.2, 0.5)
teen	(0.9, 0.1)	(0.8, 0.2)	(0.6, 0.4)	(0.7, 0.4)
adult	(0.7, 0.4)	(0.6, 0.4)	(0.1, 0.6)	(0.6, 0.8)

Then (\tilde{P}, A) is a child-Pythagorean fuzzy soft BCC-subalgebra of X . But (\tilde{P}, A) is not a child-Pythagorean fuzzy soft near BCC-filter of X since

$$\begin{aligned} \mu_{\tilde{P}[\text{child}]}(\text{Thai tea} \cdot \text{Latte}) &= \mu_{\tilde{P}[\text{child}]}(\text{Thai tea}) \\ &= 0.3 \\ &\neq 0.9 \\ &= \mu_{\tilde{P}[\text{child}]}(\text{Latte}) \end{aligned}$$

and

$$\nu_{\tilde{P}[\text{child}]}(\text{Thai tea} \cdot \text{Latte}) = \nu_{\tilde{P}[\text{child}]}(\text{Thai tea})$$

$$\begin{aligned}
&= 0.4 \\
&\not\leq 0.2 \\
&= \nu_{\tilde{P}[\text{child}]}(\text{Latte}).
\end{aligned}$$

Hence, $\tilde{P}[\text{child}]$ is not a Pythagorean fuzzy near BCC-filter of X , that is, (\tilde{P}, A) is not a child-Pythagorean fuzzy soft near BCC-filter of X .

Definition 5.1.8 A Pythagorean fuzzy soft set (\tilde{P}, A) over X is called a *Pythagorean fuzzy soft BCC-filter* based on $a \in A$ (we shortly call an *a-Pythagorean fuzzy soft BCC-filter*) of X if a Pythagorean fuzzy set $\tilde{P}[a]$ in X is a Pythagorean fuzzy BCC-filter. If (\tilde{P}, A) is an *a-Pythagorean fuzzy soft BCC-filter* of X for all $a \in A$, we say that (\tilde{P}, A) is a *Pythagorean fuzzy soft BCC-filter* of X .

The proof of the following theorem can be verified easily.

Theorem 5.1.9 *If (\tilde{P}, A) is a Pythagorean fuzzy soft BCC-filter of X and $\emptyset \neq B \subseteq A$, then $(\tilde{P}|_B, B)$ is a Pythagorean fuzzy soft BCC-filter of X .*

From Figure 1, we have the following theorem.

Theorem 5.1.10 *Every a-Pythagorean fuzzy soft BCC-filter of X is an a-Pythagorean fuzzy soft near BCC-filter. Moreover, every Pythagorean fuzzy soft BCC-filter of X is a Pythagorean fuzzy soft near BCC-filter.*

The following example shows that the converse of Theorem 5.1.10 is not true.

Example 5.1.11 Let X be a set of four Apple's product, that is,

$$X = \{\text{iPhone, iPad, Mac, Watch}\}.$$

Define binary operation \cdot on X as the following Cayley table:

\cdot	iPhone	iPad	Mac	Watch
iPhone	iPhone	iPad	Mac	Watch
iPad	iPhone	iPhone	Mac	Watch
Mac	iPhone	iPhone	iPhone	Watch
Watch	iPhone	iPhone	iPhone	iPhone

Then $X = (X, \cdot, \text{iPhone})$ is a BCC-algebra. Let (\tilde{P}, A) be a Pythagorean fuzzy soft set over X where

$$A := \{\text{student, athlete, programmer}\}$$

with $\tilde{P}[\text{student}]$, $\tilde{P}[\text{athlete}]$, and $\tilde{P}[\text{programmer}]$ are Pythagorean fuzzy sets in X defined as follows:

\tilde{P}	iPhone	iPad	Mac	Watch
student	(0.9, 0.1)	(0.7, 0.4)	(0.8, 0.2)	(0.2, 0.6)
athlete	(0.7, 0.4)	(0.6, 0.5)	(0.7, 0.4)	(0.2, 0.6)
programmer	(0.8, 0.2)	(0.5, 0.7)	(0.6, 0.5)	(0.8, 0.2)

Then (\tilde{P}, A) is a programmer-Pythagorean fuzzy soft near BCC-filter of X . But (\tilde{P}, A) is not a programmer-Pythagorean fuzzy soft BCC-filter of X since

$$\begin{aligned}
 \mu_{\tilde{P}[\text{programmer}]}(\text{iPad}) &= 0.5 \\
 &\not\geq 0.6 \\
 &= \min\{0.8, 0.6\} \\
 &= \min\{\mu_{\tilde{P}[\text{programmer}]}(\text{iPhone}), \mu_{\tilde{P}[\text{programmer}]}(\text{Mac})\} \\
 &= \min\{\mu_{\tilde{P}[\text{programmer}]}(\text{Mac} \cdot \text{iPad}), \mu_{\tilde{P}[\text{programmer}]}(\text{Mac})\}
 \end{aligned}$$

and

$$\begin{aligned}
\nu_{\tilde{P}[\text{programmer}]}(\text{iPad}) &= 0.7 \\
&\not\leq 0.5 \\
&= \max\{0.2, 0.5\} \\
&= \max\{\nu_{\tilde{P}[\text{programmer}]}(\text{iPhone}), \nu_{\tilde{P}[\text{programmer}]}(\text{Mac})\} \\
&= \max\{\nu_{\tilde{P}[\text{programmer}]}(\text{Mac} \cdot \text{iPad}), \nu_{\tilde{P}[\text{programmer}]}(\text{Mac})\}.
\end{aligned}$$

Hence, $\tilde{P}[\text{programmer}]$ is not a Pythagorean fuzzy BCC-filter of X , that is, (\tilde{P}, A) is not a programmer-Pythagorean fuzzy soft BCC-filter of X .

Definition 5.1.12 A Pythagorean fuzzy soft set (\tilde{P}, A) over X is called a *Pythagorean fuzzy soft implicative BCC-filter* based on the element $a \in A$ (we shortly call an *a-Pythagorean fuzzy soft implicative BCC-filter* of X if a Pythagorean fuzzy set $\tilde{P}[a]$ in X is a Pythagorean fuzzy implicative BCC-filter. If (\tilde{P}, A) is an *a-Pythagorean fuzzy soft implicative BCC-filter* of X for all $a \in A$, we say that (\tilde{P}, A) is a *Pythagorean fuzzy soft implicative BCC-filter* of X .

The proof of the following theorem can be verified easily.

Theorem 5.1.13 *If (\tilde{P}, A) is a Pythagorean fuzzy soft implicative BCC-filter of X and $\emptyset \neq B \subseteq A$, then $(\tilde{P}|_B, B)$ is a Pythagorean fuzzy soft implicative BCC-filter of X .*

From Figure 1, we have the following theorem.

Theorem 5.1.14 *Every a-Pythagorean fuzzy soft implicative BCC-filter of X is an a-Pythagorean fuzzy soft BCC-filter. Moreover, every Pythagorean fuzzy soft implicative BCC-filter of X is a Pythagorean fuzzy soft BCC-filter.*

The following example shows that the converse of Theorem 5.1.14 is not true.

Example 5.1.15 Let X be a set of 5 countries, that is,

$$X = \{\text{Australia, Korea, Japan, Malaysia, Singapore}\}.$$

Define a binary operation \cdot on X as the following Cayley table:

\cdot	Australia	Malaysia	Japan	Korea	Singapore
Australia	Australia	Malaysia	Japan	Korea	Singapore
Malaysia	Australia	Australia	Japan	Korea	Singapore
Japan	Australia	Australia	Australia	Korea	Singapore
Korea	Australia	Australia	Malaysia	Australia	Singapore
Singapore	Australia	Australia	Australia	Australia	Australia

Then $X = (X, \cdot, \text{Australia})$ is a BCC-algebra. Let

$$A = \{\text{Employee, Chef, Musician}\}$$

be a set of 3 occupations of Thai people that live in X and (\tilde{P}, A) a Pythagorean fuzzy soft set over X . Then $\tilde{P}[\text{Employee}]$, $\tilde{P}[\text{Chef}]$, and $\tilde{P}[\text{Musician}]$ are Pythagorean fuzzy sets in X defined as follows:

\tilde{P}	Australia	Malaysia	Japan	Korea	Singapore
Employee	(1, 0)	(0.5, 0.3)	(0.2, 0.7)	(0.1, 0.8)	(0, 0.9)
Chef	(0.9, 0.4)	(0.6, 0.6)	(0.3, 0.7)	(0.1, 0.8)	(0.1, 0.9)
Musician	(0.8, 0.2)	(0.4, 0.3)	(0.3, 0.4)	(0.2, 0.8)	(0.1, 0.9)

Then (\tilde{P}, A) is a Pythagorean fuzzy soft BCC-filter of X . But (\tilde{P}, A) is not a Pythagorean fuzzy soft implicative BCC-filter of X because (\tilde{P}, A) is not an Employee-Pythagorean fuzzy soft implicative BCC-filter, a Chef-Pythagorean fuzzy soft implicative BCC-filter, and a Musician-Pythagorean fuzzy soft im-

plicative BCC-filter of X such as

$$\begin{aligned}
 & \mu_{\tilde{P}[\text{Chef}]}(\text{Korea} \cdot \text{Japan}) \\
 &= \mu_{\tilde{P}[\text{Chef}]}(\text{Malaysia}) \\
 &= 0.6 \\
 &\not\geq 0.9 \\
 &= \min\{0.9, 0.9\} \\
 &= \min\{\mu_{\tilde{P}[\text{Chef}]}(\text{Australia}), \mu_{\tilde{P}[\text{Chef}]}(\text{Australia})\} \\
 &= \min\{\mu_{\tilde{P}[\text{Chef}]}(\text{Korea} \cdot (\text{Korea} \cdot \text{Japan})), \mu_{\tilde{P}[\text{Chef}]}(\text{Korea} \cdot \text{Korea})\}.
 \end{aligned}$$

Hence, $\tilde{P}[\text{Chef}]$ is not a Pythagorean fuzzy implicative BCC-filter of X , that is, (\tilde{P}, A) is not a Pythagorean fuzzy soft implicative BCC-filter of X .

Definition 5.1.16 A Pythagorean fuzzy soft set (\tilde{P}, A) over X is called a *Pythagorean fuzzy soft comparative BCC-filter* based on $a \in A$ (we shortly call an *a-Pythagorean fuzzy soft comparative BCC-filter* of X if a Pythagorean fuzzy set $\tilde{P}[a]$ in X is a Pythagorean fuzzy comparative BCC-filter. If (\tilde{P}, A) is an *a-Pythagorean fuzzy soft comparative BCC-filter* of X for all $a \in A$, we say that (\tilde{P}, A) is a *Pythagorean fuzzy soft comparative BCC-filter* of X .

The proof of the following theorem can be verified easily.

Theorem 5.1.17 *If (\tilde{P}, A) is a Pythagorean fuzzy soft comparative BCC-filter of X and $\emptyset \neq B \subseteq A$, then $(\tilde{P}|_B, B)$ is a Pythagorean fuzzy soft comparative BCC-filter of X .*

From Figure 1, we have the following theorem.

Theorem 5.1.18 *Every a-Pythagorean fuzzy soft comparative BCC-filter of X is an a-Pythagorean fuzzy soft BCC-filter. Moreover, every Pythagorean fuzzy soft comparative BCC-filter of X is a Pythagorean fuzzy soft BCC-filter.*

The following example shows that the converse of Theorem 5.1.18 is not true.

Example 5.1.19 By Example 5.1.15, we have (\tilde{P}, A) is a Pythagorean fuzzy soft BCC-filter of X . But (\tilde{P}, A) is not a Pythagorean fuzzy soft comparative BCC-filter of X because (\tilde{P}, A) is not an Employee-Pythagorean fuzzy soft comparative BCC-filter, a Chef-Pythagorean fuzzy soft comparative BCC-filter, and a Musician-Pythagorean fuzzy soft comparative BCC-filter of X such as

$$\begin{aligned} & \nu_{\tilde{P}[\text{Employee}]}(\text{Japan}) \\ &= 0.7 \\ &\not\leq 0.3 \\ &= \max\{0, 0.3\} \\ &= \max\{\nu_{\tilde{P}[\text{Employee}]}(\text{Australia}), \nu_{\tilde{P}[\text{Employee}]}(\text{Malaysia})\} \\ &= \max\{\nu_{\tilde{P}[\text{Employee}]}(\text{Malaysia} \cdot ((\text{Japan} \cdot \text{Korea}) \cdot \text{Japan})), \nu_{\tilde{P}[\text{Employee}]}(\text{Malaysia})\}. \end{aligned}$$

Hence, $\tilde{P}[\text{Employee}]$ is not a Pythagorean fuzzy comparative BCC-filter of X , that is, (\tilde{P}, A) is not a Pythagorean fuzzy soft comparative BCC-filter of X .

Definition 5.1.20 A Pythagorean fuzzy soft set (\tilde{P}, A) over X is called a *Pythagorean fuzzy soft shift BCC-filter* based on $a \in A$ (we shortly call an *a-Pythagorean fuzzy soft shift BCC-filter* of X if a Pythagorean fuzzy set $\tilde{P}[a]$ in X is a Pythagorean fuzzy shift BCC-filter. If (\tilde{P}, A) is an *a-Pythagorean fuzzy soft shift BCC-filter* of X for all $a \in A$, we say that (\tilde{P}, A) is a *Pythagorean fuzzy soft shift BCC-filter* of X .

The proof of the following theorem can be verified easily.

Theorem 5.1.21 *If (\tilde{P}, A) is a Pythagorean fuzzy soft shift BCC-filter of X and $\emptyset \neq B \subseteq A$, then $(\tilde{P}|_B, B)$ is a Pythagorean fuzzy soft shift BCC-filter of X .*

From Figure 1, we have the following theorem.

Theorem 5.1.22 *Every a -Pythagorean fuzzy soft shift BCC-filter of X is an a -Pythagorean fuzzy soft BCC-filter. Moreover, every Pythagorean fuzzy soft shift BCC-filter of X is a Pythagorean fuzzy soft BCC-filter.*

The following example shows that the converse of Theorem 5.1.18 is not true.

Example 5.1.23 By Example 5.1.15, we have (\tilde{P}, A) is a Pythagorean fuzzy soft BCC-filter of X . But (\tilde{P}, A) is not a Pythagorean fuzzy soft shift BCC-filter of X because (\tilde{P}, A) is not an Employee-Pythagorean fuzzy soft shift BCC-filter, a Chef-Pythagorean fuzzy soft shift BCC-filter, and a Musician-Pythagorean fuzzy soft shift BCC-filter of X such as

$$\begin{aligned}
 & \mu_{\tilde{P}[\text{Musician}]}\left(\left(\left(\text{Japan} \cdot \text{Korea}\right) \cdot \text{Korea}\right) \cdot \text{Japan}\right) \\
 &= \mu_{\tilde{P}[\text{Musician}]}(\text{Japan}) \\
 &= 0.3 \\
 &\not\geq 0.4 \\
 &= \min\{0.4, 0.8\} \\
 &= \min\{\mu_{\tilde{P}[\text{Musician}]}(\text{Malaysia}), \mu_{\tilde{P}[\text{Musician}]}(\text{Australia})\} \\
 &= \min\{\mu_{\tilde{P}[\text{Musician}]}(\text{Australia} \cdot (\text{Korea} \cdot \text{Japan})), \mu_{\tilde{P}[\text{Musician}]}(\text{Australia})\}.
 \end{aligned}$$

Hence, $\tilde{P}[\text{Musician}]$ is not a Pythagorean fuzzy shift BCC-filter of X , that is, (\tilde{P}, A) is not a Pythagorean fuzzy soft shift BCC-filter of X .

Definition 5.1.24 A Pythagorean fuzzy soft set (\tilde{P}, A) over X is called a *Pythagorean fuzzy soft BCC-ideal* based on $a \in A$ (we shortly call an *a -Pythagorean fuzzy soft BCC-ideal*) of X if a Pythagorean fuzzy set $\tilde{P}[a]$ in X is a Pythagorean fuzzy BCC-ideal. If (\tilde{P}, A) is an a -Pythagorean fuzzy soft BCC-ideal of X for all $a \in A$, we say that (\tilde{P}, A) is a *Pythagorean fuzzy soft BCC-ideal* of X .

The proof of the following theorem can be verified easily.

Theorem 5.1.25 *If (\tilde{P}, A) is a Pythagorean fuzzy soft BCC-ideal of X and $\emptyset \neq B \subseteq A$, then $(\tilde{P}|_B, B)$ is a Pythagorean fuzzy soft BCC-ideal of X .*

From Figure 1, we have the following theorems.

Theorem 5.1.26 *Every a -Pythagorean fuzzy soft BCC-ideal of X is an a -Pythagorean fuzzy soft BCC-filter. Moreover, every Pythagorean fuzzy soft BCC-ideal of X is a Pythagorean fuzzy soft BCC-filter.*

Theorem 5.1.27 *Every a -Pythagorean fuzzy soft implicative BCC-filter of X is an a -Pythagorean fuzzy soft BCC-ideal. Moreover, every Pythagorean fuzzy soft implicative BCC-filter of X is a Pythagorean fuzzy soft BCC-ideal.*

The following example shows that the converse of Theorems 5.1.26 and 5.1.27 are not true.

Example 5.1.28 Let X be a set of four types of film, that is,

$$X = \{\text{Fantasy, Horror, Comedy, Action}\}.$$

Define binary operation \cdot on X as the following Cayley table:

\cdot	Comedy	Fantasy	Horror	Action
Comedy	Comedy	Fantasy	Horror	Action
Fantasy	Comedy	Comedy	Horror	Horror
Horror	Comedy	Fantasy	Comedy	Horror
Action	Comedy	Fantasy	Comedy	Comedy

Then $X = (X, \cdot, \text{Comedy})$ is a BCC-algebra. Let (\tilde{P}, A) be a Pythagorean fuzzy

soft set over X where

$$A := \{\text{variety, violence, entertainment}\}$$

with $\tilde{P}[\text{variety}]$, $\tilde{P}[\text{violence}]$, and $\tilde{P}[\text{entertainment}]$ are Pythagorean fuzzy sets in X defined as follows:

\tilde{P}	Comedy	Fantasy	Horror	Action
variety	(0.7, 0.3)	(0.3, 0.5)	(0.2, 0.9)	(0.2, 0.9)
violence	(0.5, 0.5)	(0.2, 0.7)	(0.7, 0.7)	(0.4, 0.8)
entertainment	(0.8, 0.2)	(0.5, 0.7)	(0.6, 0.5)	(0.6, 0.5)

Then (\tilde{P}, A) is a variety-Pythagorean fuzzy soft BCC-filter of X . But (\tilde{P}, A) is not a variety-Pythagorean fuzzy soft BCC-ideal of X since

$$\begin{aligned}
 \mu_{\tilde{P}[\text{variety}]}(\text{Horror} \cdot \text{Action}) &= \mu_{\tilde{P}[\text{variety}]}(\text{Horror}) \\
 &= 0.2 \\
 &\not\geq 0.3 \\
 &= \min\{0.7, 0.3\} \\
 &= \min\{\mu_{\tilde{P}[\text{variety}]}(\text{Comedy}), \mu_{\tilde{P}[\text{variety}]}(\text{Fantasy})\} \\
 &= \min\{\mu_{\tilde{P}[\text{variety}]}(\text{Horror} \cdot (\text{Fantasy} \cdot \text{Action})), \\
 &\quad \mu_{\tilde{P}[\text{variety}]}(\text{Fantasy})\}
 \end{aligned}$$

and

$$\begin{aligned}
 \nu_{\tilde{P}[\text{variety}]}(\text{Horror} \cdot \text{Action}) &= \nu_{\tilde{P}[\text{variety}]}(\text{Horror}) \\
 &= 0.9 \\
 &\not\leq 0.5
 \end{aligned}$$

$$\begin{aligned}
&= \max\{0.3, 0.5\} \\
&= \max\{\nu_{\tilde{P}[\text{variety}]}(\text{Comedy}), \nu_{\tilde{P}[\text{variety}]}(\text{Fantasy})\} \\
&= \max\{\nu_{\tilde{P}[\text{variety}]}(\text{Horror} \cdot (\text{Fantasy} \cdot \text{Action})), \\
&\nu_{\tilde{P}[\text{variety}]}(\text{Fantasy})\}.
\end{aligned}$$

Hence, $\tilde{P}[\text{variety}]$ is not a Pythagorean fuzzy BCC-ideal of X , that is, (\tilde{P}, A) is not a variety-Pythagorean fuzzy soft BCC-ideal of X .

Example 5.1.29 By Example 5.1.15, we have (\tilde{P}, A) is a Pythagorean fuzzy soft BCC-ideal of X . But (\tilde{P}, A) is not a Pythagorean fuzzy soft implicative BCC-filter of X because (\tilde{P}, A) is not an Employee-Pythagorean fuzzy soft implicative BCC-filter, a Chef-Pythagorean fuzzy soft implicative BCC-filter, and a Musician-Pythagorean fuzzy soft implicative BCC-filter of X such as

$$\begin{aligned}
&\nu_{\tilde{P}[\text{Musician}]}(\text{Korea} \cdot \text{Japan}) \\
&= \nu_{\tilde{P}[\text{Musician}]}(\text{Malaysia}) \\
&= 0.3 \\
&\not\leq 0.2 \\
&= \max\{0.2, 0.2\} \\
&= \max\{\nu_{\tilde{P}[\text{Musician}]}(\text{Australia}), \nu_{\tilde{P}[\text{Musician}]}(\text{Australia})\} \\
&= \max\{\nu_{\tilde{P}[\text{Musician}]}(\text{Korea} \cdot (\text{Korea} \cdot \text{Japan})), \nu_{\tilde{P}[\text{Musician}]}(\text{Korea} \cdot \text{Korea})\}.
\end{aligned}$$

Hence, $\tilde{P}[\text{Musician}]$ is not a Pythagorean fuzzy implicative BCC-filter of X , that is, (\tilde{P}, A) is not a Pythagorean fuzzy soft implicative BCC-filter of X .

Definition 5.1.30 A Pythagorean fuzzy soft set (\tilde{P}, A) over X is called a *Pythagorean fuzzy soft strong BCC-ideal* based on $a \in A$ (we shortly call an *a-Pythagorean fuzzy soft strong BCC-ideal*) of X if a Pythagorean fuzzy set $\tilde{P}[a]$ in X is a Pythagorean fuzzy strong BCC-ideal. If $\tilde{P}[a]$ is an *a-Pythagorean fuzzy soft*

strong BCC-ideal of X for all $a \in A$, we say that $\tilde{P}[a]$ is a *Pythagorean fuzzy soft strong BCC-ideal* of X .

The proof of the following theorem can be verified easily.

Theorem 5.1.31 *If (\tilde{P}, A) is a Pythagorean fuzzy soft strong BCC-ideal of X and $\emptyset \neq B \subseteq A$, then $(\tilde{P}|_B, B)$ is a Pythagorean fuzzy soft strong BCC-ideal of X .*

From Figure 1, we have the following theorems.

Theorem 5.1.32 *a -Pythagorean fuzzy soft strong BCC-ideal and a -constant Pythagorean fuzzy soft set coincide in X . Moreover, Pythagorean fuzzy soft strong BCC-ideal and constant Pythagorean fuzzy soft set coincide in X .*

Theorem 5.1.33 *Every a -Pythagorean fuzzy soft strong BCC-ideal of X is an a -Pythagorean fuzzy soft BCC-ideal. Moreover, every Pythagorean fuzzy soft strong BCC-ideal of X is a Pythagorean fuzzy soft BCC-ideal.*

Theorem 5.1.34 *Every a -Pythagorean fuzzy soft strong BCC-ideal of X is an a -Pythagorean fuzzy soft implicative BCC-filter (resp., a -Pythagorean fuzzy soft comparative BCC-filter, a -Pythagorean fuzzy soft shift BCC-filter). Moreover, every Pythagorean fuzzy soft strong BCC-ideal of X is a Pythagorean fuzzy soft implicative BCC-filter (resp., Pythagorean fuzzy soft comparative BCC-filter, Pythagorean fuzzy soft shift BCC-filter).*

The following example shows that the converse of Theorems 5.1.33 and 5.1.34 are not true.

Example 5.1.35 Let X be a set of four games of E-sports, that is,

$$X = \{\text{DOTA, Pokemon, Call of Duty, FIFA}\}.$$

Define binary operation \cdot on X as the following Cayley table:

\cdot	DOTA	FIFA	Call of Duty	Pokemon
DOTA	DOTA	FIFA	Call of Duty	Pokemon
Pokemon	DOTA	DOTA	FIFA	Pokemon
Call of Duty	DOTA	DOTA	DOTA	Pokemon
FIFA	DOTA	FIFA	Call of Duty	DOTA

Then $X = (X, \cdot, \text{DOTA})$ is a BCC-algebra. Let (\tilde{P}, A) be a Pythagorean fuzzy soft set over X where

$$A := \{\text{pressure, planning, relaxation}\}$$

with $\tilde{P}[\text{pressure}]$, $\tilde{P}[\text{planning}]$, and $\tilde{P}[\text{relaxation}]$ are Pythagorean fuzzy sets in X defined as follows:

\tilde{P}	DOTA	FIFA	Call of Duty	Pokemon
pressure	(1, 0)	(0.7, 0.3)	(0.7, 0.3)	(0.2, 0.8)
planning	(0.8, 0.4)	(0.6, 0.6)	(0.6, 0.6)	(0.3, 0.9)
relaxation	(0.2, 0.4)	(0.3, 0.4)	(0.3, 0.6)	(0.6, 0.4)

Then (\tilde{P}, A) is a planning-Pythagorean fuzzy soft BCC-ideal of X . But (\tilde{P}, A) is not a planning-Pythagorean fuzzy soft strong BCC-ideal of X since

$$\begin{aligned}
 & \mu_{\tilde{P}[\text{planning}]}(\text{Call of Duty}) \\
 &= 0.6 \\
 &\not\geq 0.8 \\
 &= \min\{0.8, 0.8\} \\
 &= \min\{\mu_{\tilde{P}[\text{planning}]}(\text{DOTA}), \mu_{\tilde{P}[\text{planning}]}(\text{DOTA})\}
 \end{aligned}$$

$$= \min\{\mu_{\tilde{P}[\text{planning}]}\left(\left(\text{Call of Duty} \cdot \text{DOTA}\right) \cdot \left(\text{Call of Duty} \cdot \text{Call of Duty}\right)\right), \mu_{\tilde{P}[\text{planning}]}(\text{DOTA})\}$$

and

$$\begin{aligned} & \nu_{\tilde{P}[\text{planning}]}(\text{Call of Duty}) \\ &= 0.6 \\ &\not\leq 0.4 \\ &= \max\{0.4, 0.4\} \\ &= \max\{\nu_{\tilde{P}[\text{planning}]}(\text{DOTA}), \nu_{\tilde{P}[\text{planning}]}(\text{DOTA})\} \\ &= \max\{\nu_{\tilde{P}[\text{planning}]}(\left(\text{Call of Duty} \cdot \text{DOTA}\right) \cdot \left(\text{Call of Duty} \cdot \text{Call of Duty}\right)), \nu_{\tilde{P}[\text{planning}]}(\text{DOTA})\}. \end{aligned}$$

Hence, $\tilde{P}[\text{planning}]$ is not a Pythagorean fuzzy strong BCC-ideal of X , that is, (\tilde{P}, A) is not a planning-Pythagorean fuzzy soft strong BCC-ideal of X .

Example 5.1.36 Let X be a set of 5 internet stocks, that is,

$$X = \{x_1, x_2, x_3, x_4, x_5\}.$$

Define a binary operation \cdot on X as the following Cayley table:

\cdot	x_1	x_2	x_3	x_4	x_5
x_1	x_1	x_2	x_3	x_4	x_5
x_2	x_1	x_1	x_2	x_3	x_5
x_3	x_1	x_1	x_1	x_3	x_5
x_4	x_1	x_1	x_1	x_1	x_5
x_5	x_1	x_1	x_1	x_3	x_1

Then $X = (X, \cdot, x_1)$ is a BCC-algebra. Let

$$\begin{aligned} A &= \{\text{Market trend, Annual performance, Circulation market value}\} \\ &= \{\text{MT, AP, CMV}\} \end{aligned}$$

be a set of 3 evaluations in X and (\tilde{P}, A) a Pythagorean fuzzy soft set over X . Then $\tilde{P}[\text{MT}]$, $\tilde{P}[\text{AP}]$, and $\tilde{P}[\text{CMV}]$ are Pythagorean fuzzy sets in X defined as follows:

\tilde{P}	x_1	x_2	x_3	x_4	x_5
MT	(0.8, 0.2)	(0.8, 0.2)	(0.8, 0.2)	(0.8, 0.2)	(0.4, 0.7)
AP	(0.5, 0.3)	(0.5, 0.3)	(0.5, 0.3)	(0.5, 0.3)	(0.5, 0.3)
CMV	(0.7, 0.3)	(0.7, 0.3)	(0.7, 0.3)	(0.7, 0.3)	(0.2, 0.9)

Then (\tilde{P}, A) is a Pythagorean fuzzy soft implicative BCC-filter (Pythagorean fuzzy soft comparative BCC-filter, Pythagorean fuzzy soft shift BCC-filter) of X . But (\tilde{P}, A) is not a Pythagorean fuzzy soft strong BCC-ideal of X because (\tilde{P}, A) is not a MT-constant Pythagorean fuzzy soft set (CMV-constant Pythagorean fuzzy soft set) of X . Hence, $\tilde{P}[\text{MT}]$ and $\tilde{P}[\text{CMV}]$ are not a Pythagorean fuzzy strong BCC-ideal of X , that is, (\tilde{P}, A) is not a Pythagorean fuzzy soft strong BCC-ideal of X .

Next, we shall find examples for study generalization of Pythagorean fuzzy soft sets over BCC-algebras.

Example 5.1.37 By Example 5.1.15, we have (\tilde{P}, A) is a Pythagorean fuzzy soft BCC-ideal of X . But (\tilde{P}, A) is not a Pythagorean fuzzy soft comparative BCC-filter of X because (\tilde{P}, A) is not an Employee-Pythagorean fuzzy soft comparative BCC-filter, a Chef-Pythagorean fuzzy soft comparative BCC-filter, and

a Musician-Pythagorean fuzzy soft comparative BCC-filter of X such as

$$\begin{aligned}
& \mu_{\tilde{P}[\text{Chef}]}(\text{Korea}) \\
&= 0.1 \\
&\not\geq 0.3 \\
&= \min\{0.9, 0.3\} \\
&= \min\{\mu_{\tilde{P}[\text{Chef}]}(\text{Australia}), \mu_{\tilde{P}[\text{Chef}]}(\text{Japan})\} \\
&= \min\{\mu_{\tilde{P}[\text{Chef}]}(\text{Japan} \cdot ((\text{Korea} \cdot \text{Singapore}) \cdot \text{Korea})), \mu_{\tilde{P}[\text{Chef}]}(\text{Japan})\}.
\end{aligned}$$

Hence, $\tilde{P}[\text{Chef}]$ is not a Pythagorean fuzzy comparative BCC-filter of X , that is, (\tilde{P}, A) is not a Pythagorean fuzzy soft comparative BCC-filter of X .

Example 5.1.38 By Example 5.1.15, we have (\tilde{P}, A) is a Pythagorean fuzzy soft BCC-ideal of X . But (\tilde{P}, A) is not a Pythagorean fuzzy soft shift BCC-filter of X because (\tilde{P}, A) is not an Employee-Pythagorean fuzzy soft shift BCC-filter, a Chef-Pythagorean fuzzy soft shift BCC-filter, and a Musician-Pythagorean fuzzy soft shift BCC-filter of X such as

$$\begin{aligned}
& \nu_{\tilde{P}[\text{Employee}]}(((\text{Korea} \cdot \text{Singapore}) \cdot \text{Singapore}) \cdot \text{Korea}) \\
&= \nu_{\tilde{P}[\text{Employee}]}(\text{Korea}) \\
&= 0.8 \\
&\not\geq 0.7 \\
&= \max\{0, 0.7\} \\
&= \max\{\nu_{\tilde{P}[\text{Employee}]}(\text{Malaysia}), \nu_{\tilde{P}[\text{Employee}]}(\text{Japan})\} \\
&= \max\{\nu_{\tilde{P}[\text{Employee}]}(\text{Japan} \cdot (\text{Singapore} \cdot \text{Korea})), \nu_{\tilde{P}[\text{Employee}]}(\text{Japan})\}.
\end{aligned}$$

Hence, $\tilde{P}[\text{Employee}]$ is not a Pythagorean fuzzy shift BCC-filter of X , that is, (\tilde{P}, A) is not a Pythagorean fuzzy soft shift BCC-filter of X .

Example 5.1.39 Let X be a set of 4 cars, that is, $X = \{c_1, c_2, c_3, c_4\}$. Define a binary operation \cdot on X as the following Cayley table:

\cdot	c_1	c_2	c_3	c_4
c_1	c_1	c_2	c_3	c_4
c_2	c_1	c_1	c_3	c_3
c_3	c_1	c_1	c_1	c_3
c_4	c_1	c_1	c_1	c_1

Then $X = (X, \cdot, c_1)$ is a BCC-algebra. Let $A = \{\text{Price, Modernity, Engine torque}\}$ be a set of purchasing decisions in X and (\tilde{P}, A) a Pythagorean fuzzy soft set over X . Then $\tilde{P}[\text{Price}]$, $\tilde{P}[\text{Modernity}]$, and $\tilde{P}[\text{Engine torque}]$ are Pythagorean fuzzy sets in X defined as follows:

\tilde{P}	c_1	c_2	c_3	c_4
Price	(0.7, 0.5)	(0.7, 0.5)	(0.3, 0.6)	(0.3, 0.6)
Modernity	(0.9, 0.4)	(0.9, 0.4)	(0.1, 0.8)	(0.1, 0.8)
Engine torque	(0.8, 0.3)	(0.8, 0.3)	(0.2, 0.4)	(0.2, 0.4)

Then (\tilde{P}, A) is a Pythagorean fuzzy soft shift BCC-filter of X . But (\tilde{P}, A) is not a Pythagorean fuzzy soft implicative BCC-filter of X because (\tilde{P}, A) is not a Price-Pythagorean fuzzy soft implicative BCC-filter, a Modernity-Pythagorean fuzzy soft implicative BCC-filter, and an Engine torque-Pythagorean fuzzy soft implicative BCC-filter of X such as

$$\begin{aligned}
 \mu_{\tilde{P}[\text{Price}]}(c_3 \cdot c_4) &= \mu_{\tilde{P}[\text{Price}]}(c_3) \\
 &= 0.3 \\
 &\neq 0.7 \\
 &= \min\{0.7, 0.7\}
 \end{aligned}$$

$$\begin{aligned}
&= \min\{\mu_{\tilde{P}[\text{Price}]}(c_1), \mu_{\tilde{P}[\text{Price}]}(c_1)\} \\
&= \min\{\mu_{\tilde{P}[\text{Price}]}(c_3 \cdot (c_3 \cdot c_4)), \mu_{\tilde{P}[\text{Price}]}(c_3 \cdot c_3)\}.
\end{aligned}$$

Hence, $\tilde{P}[\text{Price}]$ is not a Pythagorean fuzzy implicative BCC-filter of X , that is, (\tilde{P}, A) is not a Pythagorean fuzzy soft implicative BCC-filter of X .

Example 5.1.40 By Example 5.1.39, we have (\tilde{P}, A) is a Pythagorean fuzzy soft shift BCC-filter of X . But (\tilde{P}, A) is not a Pythagorean fuzzy soft comparative BCC-filter of X because (\tilde{P}, A) is not a Price-Pythagorean fuzzy soft comparative BCC-filter, a Modernity-Pythagorean fuzzy soft comparative BCC-filter, and an Engine torque-Pythagorean fuzzy soft comparative BCC-filter of X such as

$$\begin{aligned}
\nu_{\tilde{P}[\text{Modernity}]}(c_3) &= 0.8 \\
&\not\leq 0.4 \\
&= \max\{0.4, 0.4\} \\
&= \max\{\nu_{\tilde{P}[\text{Modernity}]}(c_1), \nu_{\tilde{P}[\text{Modernity}]}(c_1)\} \\
&= \max\{\nu_{\tilde{P}[\text{Modernity}]}(c_1 \cdot ((c_3 \cdot c_4) \cdot c_3)), \nu_{\tilde{P}[\text{Modernity}]}(c_1)\}.
\end{aligned}$$

Hence, $\tilde{P}[\text{Modernity}]$ is not a Pythagorean fuzzy comparative BCC-filter of X , that is, (\tilde{P}, A) is not a Pythagorean fuzzy soft comparative BCC-filter of X .

Example 5.1.41 By Example 5.1.39, we have (\tilde{P}, A) is a Pythagorean fuzzy soft shift BCC-filter of X . But (\tilde{P}, A) is not a Pythagorean fuzzy soft BCC-ideal of X because (\tilde{P}, A) is not a Price-Pythagorean fuzzy soft BCC-ideal, a Modernity-Pythagorean fuzzy soft BCC-ideal, and an Engine torque-Pythagorean fuzzy soft BCC-ideal of X such as

$$\begin{aligned}
\mu_{\tilde{P}[\text{Engine torque}]}(c_3 \cdot c_4) &= \mu_{\tilde{P}[\text{Engine torque}]}(c_3) \\
&= 0.2
\end{aligned}$$

$$\begin{aligned}
&\not\geq 0.8 \\
&= \min\{0.8, 0.8\} \\
&= \min\{\mu_{\tilde{P}[\text{Engine torque}]}(c_1), \mu_{\tilde{P}[\text{Engine torque}]}(c_2)\} \\
&= \min\{\mu_{\tilde{P}[\text{Engine torque}]}(c_3 \cdot (c_2 \cdot c_4)), \mu_{\tilde{P}[\text{Engine torque}]}(c_2)\}.
\end{aligned}$$

Hence, $\tilde{P}[\text{Engine torque}]$ is not a Pythagorean fuzzy BCC-ideal of X , that is, (\tilde{P}, A) is not a Pythagorean fuzzy soft BCC-ideal of X .

Example 5.1.42 Let X be a set of 5 cities in Thailand, that is,

$$X = \{\text{Bangkok, Chiang Mai, Chiang Rai, Phuket, Khon Kaen}\}.$$

Define a binary operation \cdot on X as the following Cayley table:

\cdot	Bangkok	Chiang Mai	Chiang Rai	Phuket	Khon Kaen
Bangkok	Bangkok	Chiang Mai	Chiang Rai	Phuket	Khon Kaen
Chiang Mai	Bangkok	Bangkok	Bangkok	Bangkok	Khon Kaen
Chiang Rai	Bangkok	Chiang Mai	Bangkok	Bangkok	Khon Kaen
Phuket	Bangkok	Chiang Mai	Chiang Rai	Bangkok	Khon Kaen
Khon Kaen	Bangkok	Chiang Mai	Chiang Rai	Phuket	Bangkok

Then $X = (X, \cdot, \text{Bangkok})$ is a BCC-algebra. Let $A = \{\text{Crowded, Cost of living}\}$ be a set of 2 factors in X and (\tilde{P}, A) a Pythagorean fuzzy soft set over X . Then $\tilde{P}[\text{Crowded}]$ and a $\tilde{P}[\text{Cost of living}]$ are Pythagorean fuzzy sets in X defined as follows:

\tilde{P}	Bangkok	Chiang Mai	Chiang Rai	Phuket	Khon Kaen
Crowded	(0.7, 0.1)	(0.2, 0.3)	(0.2, 0.3)	(0.2, 0.3)	(0, 0.9)
Cost of living	(0.6, 0.5)	(0.3, 0.7)	(0.3, 0.7)	(0.4, 0.6)	(0.1, 0.8)

Then (\tilde{P}, A) is a Pythagorean fuzzy soft implicative BCC-filter of X . But (\tilde{P}, A) is not a Pythagorean fuzzy soft comparative BCC-filter of X because (\tilde{P}, A) is not a Crowded-Pythagorean fuzzy soft comparative BCC-filter and Cost of living-Pythagorean fuzzy soft comparative BCC-filter of X such as

$$\begin{aligned}
 \mu_{\tilde{P}[\text{Crowded}]}(\text{Phuket}) &= 0.2 \\
 &\not\geq 0.7 \\
 &= \min\{0.7, 0.7\} \\
 &= \min\{\mu_{\tilde{P}[\text{Crowded}]}(\text{Bangkok}), \mu_{\tilde{P}[\text{Crowded}]}(\text{Bangkok})\} \\
 &= \min\{\mu_{\tilde{P}[\text{Crowded}]}(\text{Bangkok} \cdot ((\text{Phuket} \cdot \text{Chiang Rai}) \cdot \text{Phuket})), \\
 &\quad \mu_{\tilde{P}[\text{Crowded}]}(\text{Bangkok})\}.
 \end{aligned}$$

Hence, $\tilde{P}[\text{Crowded}]$ is not a Pythagorean fuzzy comparative BCC-filter of X , that is, (\tilde{P}, A) is not a Pythagorean fuzzy soft comparative BCC-filter of X .

Example 5.1.43 By Example 5.1.42, we have (\tilde{P}, A) is a Pythagorean fuzzy soft implicative BCC-filter of X . But (\tilde{P}, A) is not a Pythagorean fuzzy soft shift BCC-filter of X because (\tilde{P}, A) is not a Crowded-Pythagorean fuzzy soft shift BCC-filter and a Cost of living-Pythagorean fuzzy soft shift BCC-filter of X such as

$$\begin{aligned}
 \nu_{\tilde{P}[\text{Cost of living}]}(((\text{Phuket} \cdot \text{Chiang Mai}) \cdot \text{Chiang Mai}) \cdot \text{Phuket}) \\
 &= \nu_{\tilde{P}[\text{Cost of living}]}(\text{Phuket}) \\
 &= 0.6 \\
 &\not\leq 0.5 \\
 &= \max\{0.5, 0.5\} \\
 &= \max\{\nu_{\tilde{P}[\text{Cost of living}]}(\text{Bangkok}), \nu_{\tilde{P}[\text{Cost of living}]}(\text{Bangkok})\} \\
 &= \max\{\nu_{\tilde{P}[\text{Cost of living}]}(\text{Bangkok} \cdot (\text{Chiang Mai} \cdot \text{Phuket})),
 \end{aligned}$$

$$\nu_{\tilde{P}[\text{Cost of living}]}(\text{Bangkok})\}.$$

Hence, $\tilde{P}[\text{Cost of living}]$ is not a Pythagorean fuzzy shift BCC-filter of X , that is, (\tilde{P}, A) is not a Pythagorean fuzzy soft shift BCC-filter of X .

We got the diagram of generalization of Pythagorean fuzzy soft sets over BCC-algebras, which is shown with Figure 6.

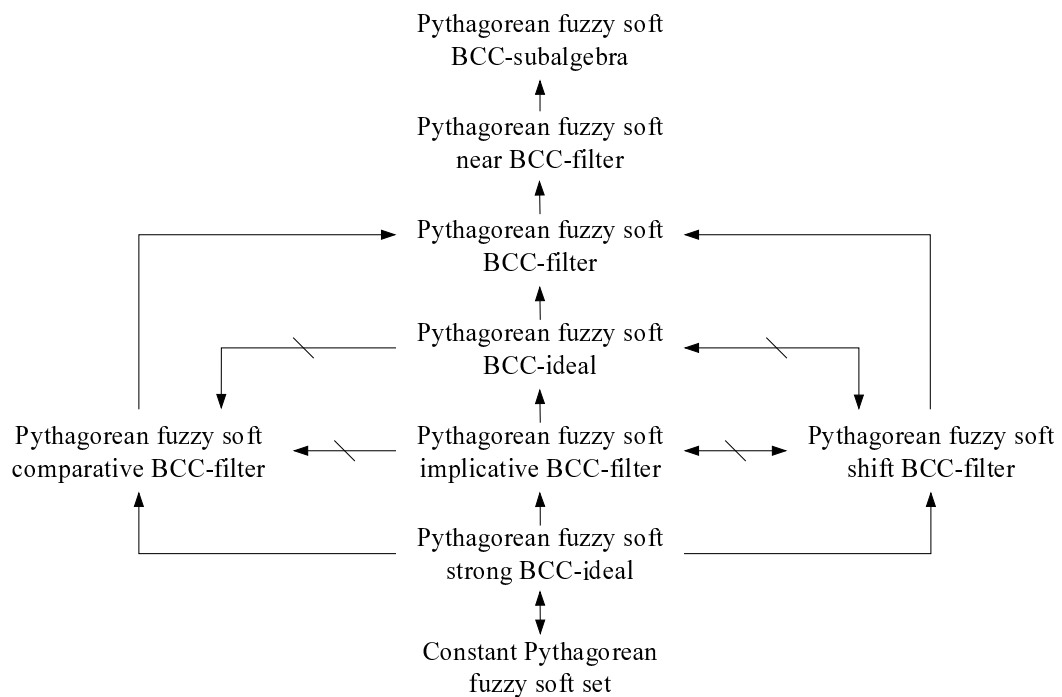

Figure 6: Pythagorean fuzzy soft sets over BCC-algebras

5.2 The operations on Pythagorean fuzzy soft sets

Theorem 5.2.1 *The extended intersection of two Pythagorean fuzzy soft BCC-subalgebras of X is also a Pythagorean fuzzy soft BCC-subalgebra. Moreover, the intersection of two Pythagorean fuzzy soft BCC-subalgebras of X is also a Pythagorean fuzzy soft BCC-subalgebra.*

Proof. Assume that (\tilde{P}_1, A_1) and (\tilde{P}_2, A_2) are two Pythagorean fuzzy soft BCC-subalgebras of X . We denote $(\tilde{P}, A_1) \tilde{\cap} (\tilde{P}_2, A_2)$ by (\tilde{P}, A) where $A = A_1 \cup A_2$. Next, let $a \in A$.

Case 1: $a \in A_1 \setminus A_2$. Then $\tilde{P}[a] = \tilde{P}_1[a]$ is a Pythagorean fuzzy BCC-subalgebra of X .

Case 2: $a \in A_2 \setminus A_1$. Then $\tilde{P}[a] = \tilde{P}_2[a]$ is a Pythagorean fuzzy BCC-subalgebra of X .

Case 3: $a \in A_1 \cap A_2$. By Theorem 3.5.1, we have $\tilde{P}[a] = \tilde{P}_1[a] \wedge \tilde{P}_2[a]$ is a Pythagorean fuzzy BCC-subalgebra of X .

Thus (\tilde{P}, A) is an a -Pythagorean fuzzy soft BCC-subalgebra of X for all $a \in A$. Hence, (\tilde{P}, A) is a Pythagorean fuzzy soft BCC-subalgebra of X . \square

Theorem 5.2.2 *The union of two Pythagorean fuzzy soft BCC-subalgebras of X is also a Pythagorean fuzzy soft BCC-subalgebra if sets of statistics of two Pythagorean fuzzy soft BCC-subalgebras are disjoint.*

Proof. Assume that (\tilde{P}_1, A_1) and (\tilde{P}_2, A_2) are two Pythagorean fuzzy soft BCC-subalgebras of X such that $A_1 \cap A_2 = \emptyset$. We denote $(\tilde{P}, A_1) \tilde{\cup} (\tilde{P}_2, A_2)$ by (\tilde{P}, A) where $A = A_1 \cup A_2$. Since $A_1 \cap A_2 = \emptyset$, we have $a \in A_1 \setminus A_2$ or $a \in A_2 \setminus A_1$. Next, let $a \in A$.

Case 1: $a \in A_1 \setminus A_2$. Then $\tilde{P}[a] = \tilde{P}_1[a]$ is a Pythagorean fuzzy BCC-subalgebra of X .

Case 2: $a \in A_2 \setminus A_1$. Then $\tilde{P}[a] = \tilde{P}_2[a]$ is a Pythagorean fuzzy BCC-subalgebra of X .

Thus (\tilde{P}, A) is an a -Pythagorean fuzzy soft BCC-subalgebra of X for all $a \in A$. Hence, (\tilde{P}, A) is a Pythagorean fuzzy soft BCC-subalgebra of X . \square

The following example shows that Theorem 5.2.2 is not valid if sets of statistics of two Pythagorean fuzzy soft BCC-subalgebras are not disjoint.

Example 5.2.3 Let X be a set of four Thai foods, that is,

$$X = \{\text{Pad Thai}, \text{Som Tam}, \text{Laab}, \text{Tom Yum Goong}\}.$$

Define binary operation \cdot on X as the following Cayley table:

\cdot	Pad Thai	Som Tam	Laab	Tom Yum Goong
Pad Thai	Pad Thai	Som Tam	Laab	Tom Yum Goong
Som Tam	Pad Thai	Pad Thai	Som Tam	Tom Yum Goong
Laab	Pad Thai	Pad Thai	Pad Thai	Tom Yum Goong
Tom Yum Goong	Pad Thai	Pad Thai	Som Tam	Pad Thai

Then $X = (X, \cdot, \text{Pad Thai})$ is a BCC-algebra. Let (\tilde{P}_1, A_1) and (\tilde{P}_2, A_2) are Pythagorean fuzzy soft sets over X where

$$A_1 := \{\text{popularity, aroma}\}$$

and

$$A_2 := \{\text{popularity, deliciousness}\}$$

with $\tilde{P}_1[\text{popularity}]$, $\tilde{P}_1[\text{aroma}]$, $\tilde{P}_2[\text{popularity}]$, and $\tilde{P}_2[\text{deliciousness}]$ are Pythagorean fuzzy sets in X defined as follows:

\tilde{P}_1	Pad Thai	Som Tam	Laab	Tom Yum Goong
popularity	(0.9, 0)	(0.5, 0.4)	(0.9, 0)	(0.3, 0.5)
aroma	(0.5, 0.4)	(0.4, 0.8)	(0.4, 0.8)	(0.4, 0.8)

\tilde{P}_2	Pad Thai	Som Tam	Laab	Tom Yum Goong
popularity	(0.9, 0.1)	(0.3, 0.7)	(0.2, 0.8)	(0.7, 0.2)
deliciousness	(0.5, 0.5)	(0.3, 0.7)	(0.2, 0.8)	(0.1, 0.9)

Then (\tilde{P}_1, A_1) and (\tilde{P}_2, A_2) are Pythagorean fuzzy soft BCC-subalgebras of X .

Since popularity $\in A_1 \cap A_2$, we have

$$\begin{aligned}
& \mu_{\tilde{P}_1[\text{popularity}] \vee \tilde{P}_2[\text{popularity}]}(\text{Tom Yum Goong} \cdot \text{Laab}) \\
&= \mu_{\tilde{P}_1[\text{popularity}] \vee \tilde{P}_2[\text{popularity}]}(\text{Som Tam}) \\
&= 0.5 \\
&\not\geq 0.7 \\
&= \min\{0.7, 0.9\} \\
&= \min\{\mu_{\tilde{P}_1[\text{popularity}] \vee \tilde{P}_2[\text{popularity}]}(\text{Tom Yum Goong}), \\
&\quad \mu_{\tilde{P}_1[\text{popularity}] \vee \tilde{P}_2[\text{popularity}]}(\text{Laab})\}.
\end{aligned}$$

Thus $\tilde{P}_1[\text{popularity}] \vee \tilde{P}_2[\text{popularity}]$ is not a Pythagorean fuzzy BCC-subalgebra of X , that is, $(\tilde{P}_1, A_1) \tilde{\cup} (\tilde{P}_2, A_2)$ is not a popularity-Pythagorean fuzzy soft BCC-subalgebra of X . Hence, $(\tilde{P}_1, A_1) \tilde{\cup} (\tilde{P}_2, A_2)$ is not a Pythagorean fuzzy soft BCC-subalgebra of X . Moreover, $(\tilde{P}_1, A_1) \tilde{\cap} (\tilde{P}_2, A_2)$ is not a Pythagorean fuzzy soft BCC-subalgebra of X .

Theorem 5.2.4 *The extended intersection of two Pythagorean fuzzy soft near BCC-filters of X is also a Pythagorean fuzzy soft near BCC-filter. Moreover, the intersection of two Pythagorean fuzzy soft near BCC-filters of X is also a Pythagorean fuzzy soft near BCC-filter.*

Proof. Assume that (\tilde{P}_1, A_1) and (\tilde{P}_2, A_2) are two Pythagorean fuzzy soft near BCC-filters of X . We denote $(\tilde{P}, A_1) \tilde{\cap} (\tilde{P}_2, A_2)$ by (\tilde{P}, A) where $A = A_1 \cup A_2$. Next, let $a \in A$.

Case 1: $a \in A_1 \setminus A_2$. Then $\tilde{P}[a] = \tilde{P}_1[a]$ is a Pythagorean fuzzy near BCC-filter of X .

Case 2: $a \in A_2 \setminus A_1$. Then $\tilde{P}[a] = \tilde{P}_2[a]$ is a Pythagorean fuzzy near BCC-filter of X .

Case 3: $a \in A_1 \cap A_2$. By Theorem 3.5.3, we have $\tilde{P}[a] = \tilde{P}_1[a] \wedge \tilde{P}_2[a]$ is a Pythagorean fuzzy near BCC-filter of X .

Thus (\tilde{P}, A) is an a -Pythagorean fuzzy soft near BCC-filter of X for all $a \in A$. Hence, (\tilde{P}, A) is a Pythagorean fuzzy soft near BCC-filter of X . \square

Theorem 5.2.5 *The union of two Pythagorean fuzzy soft near BCC-filters of X is also a Pythagorean fuzzy soft near BCC-filter. Moreover, the restricted union of two Pythagorean fuzzy soft near BCC-filters of X is also a Pythagorean fuzzy soft near BCC-filter.*

Proof. Assume that (\tilde{P}_1, A_1) and (\tilde{P}_2, A_2) are two Pythagorean fuzzy soft near BCC-filters of X . We denote $(\tilde{P}, A_1) \tilde{\cup} (\tilde{P}_2, A_2)$ by (\tilde{P}, A) where $A = A_1 \cup A_2$. Next, let $a \in A$.

Case 1: $a \in A_1 \setminus A_2$. Then $\tilde{P}[a] = \tilde{P}_1[a]$ is a Pythagorean fuzzy near BCC-filter of X .

Case 2: $a \in A_2 \setminus A_1$. Then $\tilde{P}[a] = \tilde{P}_2[a]$ is a Pythagorean fuzzy near BCC-filter of X .

Case 3: $a \in A_1 \cap A_2$. By Theorem 3.5.4, we have $\tilde{P}[a] = \tilde{P}_1[a] \vee \tilde{P}_2[a]$ is a Pythagorean fuzzy near BCC-filter of X .

Thus (\tilde{P}, A) is an a -Pythagorean fuzzy soft near BCC-filter of X for all $a \in A$. Hence, (\tilde{P}, A) is a Pythagorean fuzzy soft near BCC-filter of X . \square

Theorem 5.2.6 *The extended intersection of two Pythagorean fuzzy soft BCC-*

filters of X is also a Pythagorean fuzzy soft BCC-filter. Moreover, the intersection of two Pythagorean fuzzy soft BCC-filters of X is also a Pythagorean fuzzy soft BCC-filter.

Proof. Assume that (\tilde{P}_1, A_1) and (\tilde{P}_2, A_2) are two Pythagorean fuzzy soft BCC-filters of X . We denote $(\tilde{P}, A_1) \tilde{\cap} (\tilde{P}_2, A_2)$ by (\tilde{P}, A) where $A = A_1 \cup A_2$. Next, let $a \in A$.

Case 1: $a \in A_1 \setminus A_2$. Then $\tilde{P}[a] = \tilde{P}_1[a]$ is a Pythagorean fuzzy BCC-filter of X .

Case 2: $a \in A_2 \setminus A_1$. Then $\tilde{P}[a] = \tilde{P}_2[a]$ is a Pythagorean fuzzy BCC-filter of X .

Case 3: $a \in A_1 \cap A_2$. By Theorem 3.5.5, we have $\tilde{P}[a] = \tilde{P}_1[a] \wedge \tilde{P}_2[a]$ is a Pythagorean fuzzy BCC-filter of X .

Thus (\tilde{P}, A) is an a -Pythagorean fuzzy soft BCC-filter of X for all $a \in A$. Hence, (\tilde{P}, A) is a Pythagorean fuzzy soft BCC-filter of X . \square

Theorem 5.2.7 *The union of two Pythagorean fuzzy soft BCC-filters of X is also a Pythagorean fuzzy soft BCC-filter if sets of statistics of two Pythagorean fuzzy soft BCC-filters are disjoint.*

Proof. Assume that (\tilde{P}_1, A_1) and (\tilde{P}_2, A_2) are two Pythagorean fuzzy soft BCC-filters of X such that $A_1 \cap A_2 = \emptyset$. We denote $(\tilde{P}, A_1) \tilde{\cup} (\tilde{P}_2, A_2)$ by (\tilde{P}, A) where $A = A_1 \cup A_2$. Since $A_1 \cap A_2 = \emptyset$, we have $a \in A_1 \setminus A_2$ or $a \in A_2 \setminus A_1$. Next, let $a \in A$.

Case 1: $a \in A_1 \setminus A_2$. Then $\tilde{P}[a] = \tilde{P}_1[a]$ is a Pythagorean fuzzy BCC-filter of X .

Case 2: $a \in A_2 \setminus A_1$. Then $\tilde{P}[a] = \tilde{P}_2[a]$ is a Pythagorean fuzzy BCC-filter

of X .

Thus (\tilde{P}, A) is an a -Pythagorean fuzzy soft BCC-filter of X for all $a \in A$. Hence, (\tilde{P}, A) is a Pythagorean fuzzy soft BCC-filter of X . \square

The following example shows that Theorem 5.2.7 is not valid if sets of statistics of two Pythagorean fuzzy soft BCC-filters are not disjoint.

Example 5.2.8 Let X be a set of four seasons, that is,

$$X = \{\text{Spring, Rains, Summer, Winter}\}.$$

Define binary operation \cdot on X as the following Cayley table:

\cdot	Winter	Rains	Spring	Summer
Winter	Winter	Rains	Spring	Summer
Rains	Winter	Winter	Spring	Spring
Spring	Winter	Rains	Winter	Rains
Summer	Winter	Winter	Winter	Winter

Then $X = (X, \cdot, \text{Winter})$ is a BCC-algebra. Let (\tilde{P}_1, A_1) and (\tilde{P}_2, A_2) are Pythagorean fuzzy soft sets over X where

$$A_1 := \{\text{coldness, moisture}\}$$

and

$$A_2 := \{\text{moisture, excitement, warmth}\}$$

with $\tilde{P}_1[\text{coldness}]$, $\tilde{P}_1[\text{moisture}]$, $\tilde{P}_2[\text{moisture}]$, $\tilde{P}_2[\text{excitement}]$, and $\tilde{P}_2[\text{warmth}]$ are

Pythagorean fuzzy sets in X defined as follows:

\tilde{P}_1	Winter	Rains	Spring	Summer
coldness	(0.9, 0.4)	(0.2, 0.7)	(0.2, 0.7)	(0.2, 0.7)
moisture	(0.8, 0.2)	(0.8, 0.2)	(0.3, 0.4)	(0.3, 0.4)

\tilde{P}_2	Winter	Rains	Spring	Summer
moisture	(0.9, 0.1)	(0.1, 0.7)	(0.5, 0.4)	(0.1, 0.7)
excitement	(0.6, 0.5)	(0.3, 0.8)	(0.6, 0.5)	(0.3, 0.8)
warmth	(0.5, 0.5)	(0.5, 0.5)	(0.5, 0.5)	(0.5, 0.5)

Then (\tilde{P}_1, A_1) and (\tilde{P}_2, A_2) are Pythagorean fuzzy soft BCC-filters of X . Since $\text{moisture} \in A_1 \cap A_2$, we have

$$\begin{aligned}
 \mu_{\tilde{P}_1[\text{moisture}] \vee \tilde{P}_2[\text{moisture}]}(\text{Summer}) &= 0.3 \\
 &\not\geq 0.5 \\
 &= \min\{0.5, 0.8\} \\
 &= \min\{\mu_{\tilde{P}_1[\text{moisture}] \vee \tilde{P}_2[\text{moisture}]}(\text{Spring}), \\
 &\quad \mu_{\tilde{P}_1[\text{moisture}] \vee \tilde{P}_2[\text{moisture}]}(\text{Rains})\} \\
 &= \min\{\mu_{\tilde{P}_1[\text{moisture}] \vee \tilde{P}_2[\text{moisture}]}(\text{Rains} \cdot \text{Summer}), \\
 &\quad \mu_{\tilde{P}_1[\text{moisture}] \vee \tilde{P}_2[\text{moisture}]}(\text{Rains})\}.
 \end{aligned}$$

Thus $\tilde{P}_1[\text{moisture}] \vee \tilde{P}_2[\text{moisture}]$ is not a Pythagorean fuzzy BCC-filter of X , that is, $(\tilde{P}_1, A_1) \tilde{\cup} (\tilde{P}_2, A_2)$ is not a moisture-Pythagorean fuzzy soft BCC-filter of X . Hence, $(\tilde{P}_1, A_1) \tilde{\cup} (\tilde{P}_2, A_2)$ is not a Pythagorean fuzzy soft BCC-filter of X . Moreover, $(\tilde{P}_1, A_1) \tilde{\cap} (\tilde{P}_2, A_2)$ is not a Pythagorean fuzzy soft BCC-filter of X .

Theorem 5.2.9 *The extended intersection of two Pythagorean fuzzy soft implicative BCC-filters of X is also a Pythagorean fuzzy soft implicative BCC-filter.*

Moreover, the intersection of two Pythagorean fuzzy soft implicative BCC-filters of X is also a Pythagorean fuzzy soft implicative BCC-filter.

Proof. Assume that (\tilde{P}_1, A_1) and (\tilde{P}_2, A_2) are two Pythagorean fuzzy soft implicative BCC-filters of X . We denote $(\tilde{P}_1, A_1) \tilde{\cap} (\tilde{P}_2, A_2)$ by (\tilde{P}, A) where $A = A_1 \cup A_2$. Next, let $a \in A$.

Case 1: $a \in A_1 \setminus A_2$. Then $\tilde{P}[a] = \tilde{P}_1[a]$ is a Pythagorean fuzzy implicative BCC-filter of X .

Case 2: $a \in A_2 \setminus A_1$. Then $\tilde{P}[a] = \tilde{P}_2[a]$ is a Pythagorean fuzzy implicative BCC-filter of X .

Case 3: $a \in A_1 \cap A_2$. By Theorem 3.5.7, we have $\tilde{P}[a] = \tilde{P}_1[a] \wedge \tilde{P}_2[a]$ is a Pythagorean fuzzy implicative BCC-filter of X .

Thus (\tilde{P}, A) is an a -Pythagorean fuzzy soft implicative BCC-filter of X for all $a \in A$. Hence, (\tilde{P}, A) is a Pythagorean fuzzy soft implicative BCC-filter of X . \square

Theorem 5.2.10 *The union of two Pythagorean fuzzy soft implicative BCC-filters of X is also a Pythagorean fuzzy soft implicative BCC-filter if sets of statistics of two Pythagorean fuzzy soft implicative BCC-filters are disjoint.*

Proof. Assume that (\tilde{P}_1, A_1) and (\tilde{P}_2, A_2) are two Pythagorean fuzzy soft implicative BCC-filters of X such that $A_1 \cap A_2 = \emptyset$. We denote $(\tilde{P}_1, A_1) \tilde{\cup} (\tilde{P}_2, A_2)$ by (\tilde{P}, A) where $A = A_1 \cup A_2$. Since $A_1 \cap A_2 = \emptyset$, we have $a \in A_1 \setminus A_2$ or $a \in A_2 \setminus A_1$. Next, let $a \in A$.

Case 1: $a \in A_1 \setminus A_2$. Then $\tilde{P}[a] = \tilde{P}_1[a]$ is a Pythagorean fuzzy implicative BCC-filter of X .

Case 2: $a \in A_2 \setminus A_1$. Then $\tilde{P}[a] = \tilde{P}_2[a]$ is a Pythagorean fuzzy implicative

BCC-filter of X .

Thus (\tilde{P}, A) is an a -Pythagorean fuzzy soft implicative BCC-filter of X for all $a \in A$. Hence, (\tilde{P}, A) is a Pythagorean fuzzy soft implicative BCC-filter of X . \square

The following example shows that Theorem 5.2.10 is not valid if sets of statistics of two Pythagorean fuzzy soft implicative BCC-filters are not disjoint.

Example 5.2.11 Let X be a set of 4 musicians, that is, $X = \{m_1, m_2, m_3, m_4\}$. Define a binary operation \cdot on X as the following Cayley table:

\cdot	m_1	m_2	m_3	m_4
m_1	m_1	m_2	m_3	m_4
m_2	m_1	m_1	m_3	m_3
m_3	m_1	m_2	m_1	m_2
m_4	m_1	m_1	m_1	m_1

Then $X = (X, \cdot, m_1)$ is a BCC-algebra. Let

$A_1 = \{\text{Creative thinking, Professionalism}\}$ and

$A_2 = \{\text{Identity, Professionalism}\}$

be sets of properties in X and (\tilde{P}_1, A_1) and (\tilde{P}_2, A_2) are Pythagorean fuzzy soft sets over X . Then $\tilde{P}_1[\text{Creative thinking}]$, $\tilde{P}_1[\text{Professionalism}]$, $\tilde{P}_2[\text{Identity}]$, and $\tilde{P}_2[\text{Professionalism}]$ are Pythagorean fuzzy sets in X defined as follows:

\tilde{P}_1	m_1	m_2	m_3	m_4
Creative thinking	(0.5, 0.6)	(0.1, 0.8)	(0.4, 0.7)	(0.1, 0.8)
Professionalism	(0.9, 0.2)	(0.4, 0.5)	(0.6, 0.4)	(0.4, 0.5)

\tilde{P}_2	m_1	m_2	m_3	m_4
Identity	(1, 0)	(0.2, 0.9)	(0.7, 0.2)	(0.2, 0.9)
Professionalism	(0.6, 0)	(0.6, 0)	(0.5, 0.4)	(0.5, 0.4)

Then (\tilde{P}_1, A_1) and (\tilde{P}_2, A_2) are Pythagorean fuzzy soft implicative BCC-filters of X . Since Professionalism $\in A_1 \cap A_2$, we have

$$\begin{aligned}
& \mu_{\tilde{P}_1[\text{Professionalism}] \vee \tilde{P}_2[\text{Professionalism}]}(m_1 \cdot m_4) \\
&= \mu_{\tilde{P}_1[\text{Professionalism}] \vee \tilde{P}_2[\text{Professionalism}]}(m_4) \\
&= 0.5 \\
&\not\geq 0.6 \\
&= \min\{0.6, 0.6\} \\
&= \min\{\mu_{\tilde{P}_1[\text{Professionalism}] \vee \tilde{P}_2[\text{Professionalism}]}(m_3), \\
&\quad \mu_{\tilde{P}_1[\text{Professionalism}] \vee \tilde{P}_2[\text{Professionalism}]}(m_2)\} \\
&= \min\{\mu_{\tilde{P}_1[\text{Professionalism}] \vee \tilde{P}_2[\text{Professionalism}]}(m_1 \cdot (m_2 \cdot m_4)), \\
&\quad \mu_{\tilde{P}_1[\text{Professionalism}] \vee \tilde{P}_2[\text{Professionalism}]}(m_1 \cdot m_2)\}.
\end{aligned}$$

Thus $\tilde{P}_1[\text{Professionalism}] \vee \tilde{P}_2[\text{Professionalism}]$ is not a Pythagorean fuzzy implicative BCC-filter of X , that is, $(\tilde{P}_1, A_1) \tilde{\cup} (\tilde{P}_2, A_2)$ is not a Professionalism-Pythagorean fuzzy soft implicative BCC-filter of X . Hence, $(\tilde{P}_1, A_1) \tilde{\cup} (\tilde{P}_2, A_2)$ is not a Pythagorean fuzzy soft implicative BCC-filter of X . Moreover, $(\tilde{P}_1, A_1) \tilde{\cup} (\tilde{P}_2, A_2)$ is not a Pythagorean fuzzy soft implicative BCC-filter of X .

Theorem 5.2.12 *The extended intersection of two Pythagorean fuzzy soft comparative BCC-filters of X is also a Pythagorean fuzzy soft comparative BCC-filter. Moreover, the intersection of two Pythagorean fuzzy soft comparative BCC-filters of X is also a Pythagorean fuzzy soft comparative BCC-filter.*

Proof. Assume that (\tilde{P}_1, A_1) and (\tilde{P}_2, A_2) are two Pythagorean fuzzy soft compar-

ative BCC-filters of X . We denote $(\tilde{P}, A_1) \tilde{\cap} (\tilde{P}_2, A_2)$ by (\tilde{P}, A) where $A = A_1 \cup A_2$.

Next, let $a \in A$.

Case 1: $a \in A_1 \setminus A_2$. Then $\tilde{P}[a] = \tilde{P}_1[a]$ is a Pythagorean fuzzy comparative BCC-filter of X .

Case 2: $a \in A_2 \setminus A_1$. Then $\tilde{P}[a] = \tilde{P}_2[a]$ is a Pythagorean fuzzy comparative BCC-filter of X .

Case 3: $a \in A_1 \cap A_2$. By Theorem 3.5.9, we have $\tilde{P}[a] = \tilde{P}_1[a] \wedge \tilde{P}_2[a]$ is a Pythagorean fuzzy comparative BCC-filter of X .

Thus (\tilde{P}, A) is an a -Pythagorean fuzzy soft comparative BCC-filter of X for all $a \in A$. Hence, (\tilde{P}, A) is a Pythagorean fuzzy soft comparative BCC-filter of X . \square

Theorem 5.2.13 *The union of two Pythagorean fuzzy soft comparative BCC-filters of X is also a Pythagorean fuzzy soft comparative BCC-filter if sets of statistics of two Pythagorean fuzzy soft comparative BCC-filters are disjoint.*

Proof. Assume that (\tilde{P}_1, A_1) and (\tilde{P}_2, A_2) are two Pythagorean fuzzy soft comparative BCC-filters of X such that $A_1 \cap A_2 = \emptyset$. We denote $(\tilde{P}, A_1) \tilde{\cup} (\tilde{P}_2, A_2)$ by (\tilde{P}, A) where $A = A_1 \cup A_2$. Since $A_1 \cap A_2 = \emptyset$, we have $a \in A_1 \setminus A_2$ or $a \in A_2 \setminus A_1$. Next, let $a \in A$.

Case 1: $a \in A_1 \setminus A_2$. Then $\tilde{P}[a] = \tilde{P}_1[a]$ is a Pythagorean fuzzy comparative BCC-filter of X .

Case 2: $a \in A_2 \setminus A_1$. Then $\tilde{P}[a] = \tilde{P}_2[a]$ is a Pythagorean fuzzy comparative BCC-filter of X .

Thus (\tilde{P}, A) is an a -Pythagorean fuzzy soft comparative BCC-filter of X for all $a \in A$. Hence, (\tilde{P}, A) is a Pythagorean fuzzy soft comparative BCC-filter

of X . □

The following example shows that Theorem 5.2.13 is not valid if sets of statistics of two Pythagorean fuzzy soft comparative BCC-filters are not disjoint.

Example 5.2.14 By Example 5.2.11, we have (\tilde{P}_1, A_1) and (\tilde{P}_2, A_2) are Pythagorean fuzzy soft comparative BCC-filters of X . Since Professionalism $\in A_1 \cap A_2$, we have

$$\begin{aligned}
 & \mu_{\tilde{P}_1[\text{Professionalism}] \vee \tilde{P}_2[\text{Professionalism}]}(m_4) \\
 &= 0.5 \\
 &\neq 0.6 \\
 &= \min\{0.6, 0.6\} \\
 &= \min\{\mu_{\tilde{P}_1[\text{Professionalism}] \vee \tilde{P}_2[\text{Professionalism}]}(m_2), \\
 &\quad \mu_{\tilde{P}_1[\text{Professionalism}] \vee \tilde{P}_2[\text{Professionalism}]}(m_3)\} \\
 &= \min\{\mu_{\tilde{P}_1[\text{Professionalism}] \vee \tilde{P}_2[\text{Professionalism}]}(m_3 \cdot ((m_4 \cdot m_2) \cdot m_4)), \\
 &\quad \mu_{\tilde{P}_1[\text{Professionalism}] \vee \tilde{P}_2[\text{Professionalism}]}(m_3)\}.
 \end{aligned}$$

Thus $\tilde{P}_1[\text{Professionalism}] \vee \tilde{P}_2[\text{Professionalism}]$ is not a Pythagorean fuzzy comparative BCC-filter of X , that is, $(\tilde{P}_1, A_1) \tilde{\cup} (\tilde{P}_2, A_2)$ is not a Professionalism-Pythagorean fuzzy soft comparative BCC-filter of X . Hence, $(\tilde{P}_1, A_1) \tilde{\cup} (\tilde{P}_2, A_2)$ is not a Pythagorean fuzzy soft comparative BCC-filter of X . Moreover, $(\tilde{P}_1, A_1) \tilde{\cup} (\tilde{P}_2, A_2)$ is not a Pythagorean fuzzy soft comparative BCC-filter of X .

Theorem 5.2.15 *The extended intersection of two Pythagorean fuzzy soft shift BCC-filters of X is also a Pythagorean fuzzy soft shift BCC-filter. Moreover, the intersection of two Pythagorean fuzzy soft shift BCC-filters of X is also a Pythagorean fuzzy soft shift BCC-filter.*

Proof. Assume that (\tilde{P}_1, A_1) and (\tilde{P}_2, A_2) are two Pythagorean fuzzy soft shift

BCC-filters of X . We denote $(\tilde{P}, A_1) \tilde{\cap} (\tilde{P}_2, A_2)$ by (\tilde{P}, A) where $A = A_1 \cup A_2$. Next, let $a \in A$.

Case 1: $a \in A_1 \setminus A_2$. Then $\tilde{P}[a] = \tilde{P}_1[a]$ is a Pythagorean fuzzy shift BCC-filter of X .

Case 2: $a \in A_2 \setminus A_1$. Then $\tilde{P}[a] = \tilde{P}_2[a]$ is a Pythagorean fuzzy shift BCC-filter of X .

Case 3: $a \in A_1 \cap A_2$. By Theorem 3.5.11, we have $\tilde{P}[a] = \tilde{P}_1[a] \wedge \tilde{P}_2[a]$ is a Pythagorean fuzzy shift BCC-filter of X .

Thus (\tilde{P}, A) is an a -Pythagorean fuzzy soft shift BCC-filter of X for all $a \in A$. Hence, (\tilde{P}, A) is a Pythagorean fuzzy soft shift BCC-filter of X . \square

Theorem 5.2.16 *The union of two Pythagorean fuzzy soft shift BCC-filters of X is also a Pythagorean fuzzy soft shift BCC-filter if sets of statistics of two Pythagorean fuzzy soft shift BCC-filters are disjoint.*

Proof. Assume that (\tilde{P}_1, A_1) and (\tilde{P}_2, A_2) are two Pythagorean fuzzy soft shift BCC-filters of X such that $A_1 \cap A_2 = \emptyset$. We denote $(\tilde{P}_1, A_1) \tilde{\cup} (\tilde{P}_2, A_2)$ by (\tilde{P}, A) where $A = A_1 \cup A_2$. Since $A_1 \cap A_2 = \emptyset$, we have $a \in A_1 \setminus A_2$ or $a \in A_2 \setminus A_1$. Next, let $a \in A$.

Case 1: $a \in A_1 \setminus A_2$. Then $\tilde{P}[a] = \tilde{P}_1[a]$ is a Pythagorean fuzzy shift BCC-filter of X .

Case 2: $a \in A_2 \setminus A_1$. Then $\tilde{P}[a] = \tilde{P}_2[a]$ is a Pythagorean fuzzy shift BCC-filter of X .

Thus (\tilde{P}, A) is an a -Pythagorean fuzzy soft shift BCC-filter of X for all $a \in A$. Hence, (\tilde{P}, A) is a Pythagorean fuzzy soft shift BCC-filter of X . \square

The following example shows that Theorem 5.2.16 is not valid if sets of

statistics of two Pythagorean fuzzy soft shift BCC-filters are not disjoint.

Example 5.2.17 By Example 5.2.11, we have (\tilde{P}_1, A_1) and (\tilde{P}_2, A_2) are Pythagorean fuzzy soft shift BCC-filters of X . Since Professionalism $\in A_1 \cap A_2$, we have

$$\begin{aligned}
& \mu_{\tilde{P}_1[\text{Professionalism}] \vee \tilde{P}_2[\text{Professionalism}]}(((m_4 \cdot m_1) \cdot m_1) \cdot m_4) \\
&= \mu_{\tilde{P}_1[\text{Professionalism}] \vee \tilde{P}_2[\text{Professionalism}]}(m_4) \\
&= 0.5 \\
&\not\geq 0.6 \\
&= \min\{0.6, 0.6\} \\
&= \min\{\mu_{\tilde{P}_1[\text{Professionalism}] \vee \tilde{P}_2[\text{Professionalism}]}(m_2), \\
&\mu_{\tilde{P}_1[\text{Professionalism}] \vee \tilde{P}_2[\text{Professionalism}]}(m_3)\} \\
&= \min\{\mu_{\tilde{P}_1[\text{Professionalism}] \vee \tilde{P}_2[\text{Professionalism}]}(m_3 \cdot (m_1 \cdot m_4)), \\
&\mu_{\tilde{P}_1[\text{Professionalism}] \vee \tilde{P}_2[\text{Professionalism}]}(m_3)\}.
\end{aligned}$$

Thus $\tilde{P}_1[\text{Professionalism}] \vee \tilde{P}_2[\text{Professionalism}]$ is not a Pythagorean fuzzy shift BCC-filter of X , that is, $(\tilde{P}_1, A_1) \tilde{\cup} (\tilde{P}_2, A_2)$ is not a Professionalism-Pythagorean fuzzy soft shift BCC-filter of X . Hence, $(\tilde{P}_1, A_1) \tilde{\cup} (\tilde{P}_2, A_2)$ is not a Pythagorean fuzzy soft shift BCC-filter of X . Moreover, $(\tilde{P}_1, A_1) \tilde{\cap} (\tilde{P}_2, A_2)$ is not a Pythagorean fuzzy soft shift BCC-filter of X .

Theorem 5.2.18 *The extended intersection of two Pythagorean fuzzy soft BCC-ideals of X is also a Pythagorean fuzzy soft BCC-ideal. Moreover, the intersection of two Pythagorean fuzzy soft BCC-ideals of X is also a Pythagorean fuzzy soft BCC-ideal.*

Proof. Assume that (\tilde{P}_1, A_1) and (\tilde{P}_2, A_2) are two Pythagorean fuzzy soft BCC-ideals of X . We denote $(\tilde{P}_1, A_1) \tilde{\cap} (\tilde{P}_2, A_2)$ by (\tilde{P}, A) where $A = A_1 \cup A_2$. Next, let $a \in A$.

Case 1: $a \in A_1 \setminus A_2$. Then $\tilde{P}[a] = \tilde{P}_1[a]$ is a Pythagorean fuzzy BCC-ideal of X .

Case 2: $a \in A_2 \setminus A_1$. Then $\tilde{P}[a] = \tilde{P}_2[a]$ is a Pythagorean fuzzy BCC-ideal of X .

Case 3: $a \in A_1 \cap A_2$. By Theorem 3.5.13, we have $\tilde{P}[a] = \tilde{P}_1[a] \wedge \tilde{P}_2[a]$ is a Pythagorean fuzzy BCC-ideal of X .

Thus (\tilde{P}, A) is an a -Pythagorean fuzzy soft BCC-ideal of X for all $a \in A$. Hence, (\tilde{P}, A) is a Pythagorean fuzzy soft BCC-ideal of X . \square

Theorem 5.2.19 *The union of two Pythagorean fuzzy soft BCC-ideals of X is also a Pythagorean fuzzy soft BCC-ideal if sets of statistics of two Pythagorean fuzzy soft BCC-ideals are disjoint.*

Proof. Assume that (\tilde{P}_1, A_1) and (\tilde{P}_2, A_2) are two Pythagorean fuzzy soft BCC-ideals of X such that $A_1 \cap A_2 = \emptyset$. We denote $(\tilde{P}, A_1) \tilde{\cup} (\tilde{P}_2, A_2)$ by (\tilde{P}, A) where $A = A_1 \cup A_2$. Since $A_1 \cap A_2 = \emptyset$, we have $a \in A_1 \setminus A_2$ or $a \in A_2 \setminus A_1$. Next, let $a \in A$.

Case 1: $a \in A_1 \setminus A_2$. Then $\tilde{P}[a] = \tilde{P}_1[a]$ is a Pythagorean fuzzy BCC-ideal of X .

Case 2: $a \in A_2 \setminus A_1$. Then $\tilde{P}[a] = \tilde{P}_2[a]$ is a Pythagorean fuzzy BCC-ideal of X .

Thus (\tilde{P}, A) is an a -Pythagorean fuzzy soft BCC-ideal of X for all $a \in A$. Hence, (\tilde{P}, A) is a Pythagorean fuzzy soft BCC-ideal of X . \square

The following example shows that Theorem 5.2.19 is not valid if sets of statistics of two Pythagorean fuzzy soft BCC-ideals are not disjoint.

Example 5.2.20 In Example 5.2.8, we have (\tilde{P}_1, A_1) and (\tilde{P}_2, A_2) are Pythagorean fuzzy soft BCC-ideals of X . Since moisture $\in A_1 \cap A_2$, we have

$$\begin{aligned}
 & \mu_{\tilde{P}_1[\text{moisture}] \vee \tilde{P}_2[\text{moisture}]}(\text{Winter} \cdot \text{Summer}) \\
 &= \mu_{\tilde{P}_1[\text{moisture}] \vee \tilde{P}_2[\text{moisture}]}(\text{Summer}) \\
 &= 0.3 \\
 &\neq 0.5 \\
 &= \min\{0.8, 0.5\} \\
 &= \min\{\mu_{\tilde{P}_1[\text{moisture}] \vee \tilde{P}_2[\text{moisture}]}(\text{Rains}), \\
 &\mu_{\tilde{P}_1[\text{moisture}] \vee \tilde{P}_2[\text{moisture}]}(\text{Spring})\} \\
 &= \min\{\mu_{\tilde{P}_1[\text{moisture}] \vee \tilde{P}_2[\text{moisture}]}(\text{Winter} \cdot (\text{Spring} \cdot \text{Summer})), \\
 &\mu_{\tilde{P}_1[\text{moisture}] \vee \tilde{P}_2[\text{moisture}]}(\text{Spring})\}.
 \end{aligned}$$

Thus $\tilde{P}_1[\text{moisture}] \vee \tilde{P}_2[\text{moisture}]$ is not a Pythagorean fuzzy BCC-ideal of X , that is, $(\tilde{P}_1, A_1) \tilde{\cup} (\tilde{P}_2, A_2)$ is not a moisture-Pythagorean fuzzy soft BCC-ideal of X . Hence, $(\tilde{P}_1, A_1) \tilde{\cap} (\tilde{P}_2, A_2)$ is not a Pythagorean fuzzy soft BCC-ideal of X . Moreover, $(\tilde{P}_1, A_1) \tilde{\cup} (\tilde{P}_2, A_2)$ is not a Pythagorean fuzzy soft BCC-ideal of X .

Theorem 5.2.21 *The extended intersection of two Pythagorean fuzzy soft strong BCC-ideals of X is also a Pythagorean fuzzy soft strong BCC-ideal. Moreover, the intersection of two Pythagorean fuzzy soft strong BCC-ideals of X is also a Pythagorean fuzzy soft strong BCC-ideal.*

Proof. Assume that (\tilde{P}_1, A_1) and (\tilde{P}_2, A_2) are two Pythagorean fuzzy soft strong BCC-ideals of X . We denote $(\tilde{P}, A_1) \tilde{\cap} (\tilde{P}_2, A_2)$ by (\tilde{P}, A) where $A = A_1 \cup A_2$. Next, let $a \in A$.

Case 1: $a \in A_1 \setminus A_2$. Then $\tilde{P}[a] = \tilde{P}_1[a]$ is a Pythagorean fuzzy strong BCC-ideal of X .

Case 2: $a \in A_2 \setminus A_1$. Then $\tilde{P}[a] = \tilde{P}_2[a]$ is a Pythagorean fuzzy strong BCC-ideal of X .

Case 3: $a \in A_1 \cap A_2$. By Theorem 3.5.15, we have $\tilde{P}[a] = \tilde{P}_1[a] \wedge \tilde{P}_2[a]$ is a Pythagorean fuzzy strong BCC-ideal of X .

Thus (\tilde{P}, A) is an a -Pythagorean fuzzy soft strong BCC-ideal of X for all $a \in A$. Hence, (\tilde{P}, A) is a Pythagorean fuzzy soft strong BCC-ideal of X . \square

Theorem 5.2.22 *The union of two Pythagorean fuzzy soft strong BCC-ideals of X is also a Pythagorean fuzzy soft strong BCC-ideal. Moreover, the restricted union of two Pythagorean fuzzy soft strong BCC-ideals of X is also a Pythagorean fuzzy soft strong BCC-ideal.*

Proof. Assume that (\tilde{P}_1, A_1) and (\tilde{P}_2, A_2) are two Pythagorean fuzzy soft strong BCC-ideals of X . We denote $(\tilde{P}, A_1) \tilde{\cup} (\tilde{P}_2, A_2)$ by (\tilde{P}, A) where $A = A_1 \cup A_2$. Next, let $a \in A$.

Case 1: $a \in A_1 \setminus A_2$. Then $\tilde{P}[a] = \tilde{P}_1[a]$ is a Pythagorean fuzzy strong BCC-ideal of X .

Case 2: $a \in A_2 \setminus A_1$. Then $\tilde{P}[a] = \tilde{P}_2[a]$ is a Pythagorean fuzzy strong BCC-ideal of X .

Case 3: $a \in A_1 \cap A_2$. By Theorem 3.5.15, we have $\tilde{P}[a] = \tilde{P}_1[a] \vee \tilde{P}_2[a]$ is a Pythagorean fuzzy strong BCC-ideal of X .

Thus (\tilde{P}, A) is an a -Pythagorean fuzzy soft strong BCC-ideal of X for all $a \in A$. Hence, (\tilde{P}, A) is a Pythagorean fuzzy soft strong BCC-ideal of X . \square

5.3 t -Level subsets of Pythagorean fuzzy soft sets

Theorem 5.3.1 (\tilde{P}, A) is a Pythagorean fuzzy soft BCC-subalgebra of X if and only if $U(\mu_{\tilde{P}[a]}, t)$ and $L(\nu_{\tilde{P}[a]}, t)$ are, if the sets are nonempty, BCC-subalgebras for every $a \in A, t \in [0, 1]$.

Proof. Assume (\tilde{P}, A) is a Pythagorean fuzzy soft BCC-subalgebra of X , that is, $\tilde{P}[a] = (\mu_{\tilde{P}[a]}, \nu_{\tilde{P}[a]})$ is a Pythagorean fuzzy BCC-subalgebra of X for all $a \in A$. Let $t \in [0, 1]$ be such that $U(\mu_{\tilde{P}[a]}, t), L(\nu_{\tilde{P}[a]}, t) \neq \emptyset$. By Theorem 3.4.2, we have $U(\mu_{\tilde{P}[a]}, t)$ and $L(\nu_{\tilde{P}[a]}, t)$ are BCC-subalgebras of X for all $a \in A, t \in [0, 1]$.

Conversely, assume for all $a \in A, t \in [0, 1], U(\mu_{\tilde{P}[a]}, t)$ and $L(\nu_{\tilde{P}[a]}, t)$ are BCC-subalgebras of X if the sets are nonempty. By Theorem 3.4.2, we have $\tilde{P}[a] = (\mu_{\tilde{P}[a]}, \nu_{\tilde{P}[a]})$ is a Pythagorean fuzzy BCC-subalgebra of X for all $a \in A$. Hence, (\tilde{P}, A) is a Pythagorean fuzzy soft BCC-subalgebra of X . \square

Theorem 5.3.2 (\tilde{P}, A) is a Pythagorean fuzzy soft BCC-subalgebra of X if and only if $U^+(\mu_{\tilde{P}[a]}, t)$ and $L^-(\nu_{\tilde{P}[a]}, t)$ are, if the sets are nonempty, BCC-subalgebras for every $a \in A, t \in [0, 1]$.

Proof. Assume (\tilde{P}, A) is a Pythagorean fuzzy soft BCC-subalgebra of X , that is, $\tilde{P}[a] = (\mu_{\tilde{P}[a]}, \nu_{\tilde{P}[a]})$ is a Pythagorean fuzzy BCC-subalgebra of X for all $a \in A$. Let $t \in [0, 1]$ be such that $U^+(\mu_{\tilde{P}[a]}, t), L^-(\nu_{\tilde{P}[a]}, t) \neq \emptyset$. By Theorem 3.4.3, we have $U^+(\mu_{\tilde{P}[a]}, t)$ and $L^-(\nu_{\tilde{P}[a]}, t)$ are BCC-subalgebras of X for all $a \in A, t \in [0, 1]$.

Conversely, assume for all $a \in A, t \in [0, 1], U^+(\mu_{\tilde{P}[a]}, t)$ and $L^-(\nu_{\tilde{P}[a]}, t)$ are BCC-subalgebras of X if the sets are nonempty. By Theorem 3.4.3, we have $\tilde{P}[a] = (\mu_{\tilde{P}[a]}, \nu_{\tilde{P}[a]})$ is a Pythagorean fuzzy BCC-subalgebra of X for all $a \in A$. Hence, (\tilde{P}, A) is a Pythagorean fuzzy soft BCC-subalgebra of X . \square

Theorem 5.3.3 (\tilde{P}, A) is a Pythagorean fuzzy soft near BCC-filter of X if and only if $U(\mu_{\tilde{P}[a]}, t)$ and $L(\nu_{\tilde{P}[a]}, t)$ are, if the sets are nonempty, near BCC-filters

for every $a \in A, t \in [0, 1]$.

Proof. Assume (\tilde{P}, A) is a Pythagorean fuzzy soft near BCC-filter of X , that is, $\tilde{P}[a] = (\mu_{\tilde{P}[a]}, \nu_{\tilde{P}[a]})$ is a Pythagorean fuzzy near BCC-filter of X for all $a \in A$. Let $t \in [0, 1]$ be such that $U(\mu_{\tilde{P}[a]}, t), L(\nu_{\tilde{P}[a]}, t) \neq \emptyset$. By Theorem 3.4.4, we have $U(\mu_{\tilde{P}[a]}, t)$ and $L(\nu_{\tilde{P}[a]}, t)$ are near BCC-filters of X for all $a \in A, t \in [0, 1]$.

Conversely, assume for all $a \in A, t \in [0, 1], U(\mu_{\tilde{P}[a]}, t)$ and $L(\nu_{\tilde{P}[a]}, t)$ are near BCC-filters of X if the sets are nonempty. By Theorem 3.4.4, we have $\tilde{P}[a] = (\mu_{\tilde{P}[a]}, \nu_{\tilde{P}[a]})$ is a Pythagorean fuzzy near BCC-filter of X for all $a \in A$. Hence, (\tilde{P}, A) is a Pythagorean fuzzy soft near BCC-filter of X . \square

Theorem 5.3.4 (\tilde{P}, A) is a Pythagorean fuzzy soft near BCC-filter of X if and only if $U^+(\mu_{\tilde{P}[a]}, t)$ and $L^-(\nu_{\tilde{P}[a]}, t)$ are, if the sets are nonempty, near BCC-filters for every $a \in A, t \in [0, 1]$.

Proof. Assume (\tilde{P}, A) is a Pythagorean fuzzy soft near BCC-filter of X , that is, $\tilde{P}[a] = (\mu_{\tilde{P}[a]}, \nu_{\tilde{P}[a]})$ is a Pythagorean fuzzy near BCC-filter of X for all $a \in A$. Let $t \in [0, 1]$ be such that $U^+(\mu_{\tilde{P}[a]}, t), L^-(\nu_{\tilde{P}[a]}, t) \neq \emptyset$. By Theorem 3.4.5, we have $U^+(\mu_{\tilde{P}[a]}, t)$ and $L^-(\nu_{\tilde{P}[a]}, t)$ are near BCC-filters of X for all $a \in A, t \in [0, 1]$.

Conversely, assume for all $a \in A, t \in [0, 1], U^+(\mu_{\tilde{P}[a]}, t)$ and $L^-(\nu_{\tilde{P}[a]}, t)$ are near BCC-filters of X if the sets are nonempty. By Theorem 3.4.5, we have $\tilde{P}[a] = (\mu_{\tilde{P}[a]}, \nu_{\tilde{P}[a]})$ is a Pythagorean fuzzy near BCC-filter of X for all $a \in A$. Hence, (\tilde{P}, A) is a Pythagorean fuzzy soft near BCC-filter of X . \square

Theorem 5.3.5 (\tilde{P}, A) is a Pythagorean fuzzy soft BCC-filter of X if and only if $U(\mu_{\tilde{P}[a]}, t)$ and $L(\nu_{\tilde{P}[a]}, t)$ are, if the sets are nonempty, BCC-filters for every $a \in A, t \in [0, 1]$.

Proof. Assume (\tilde{P}, A) is a Pythagorean fuzzy soft BCC-filter of X , that is, $\tilde{P}[a] = (\mu_{\tilde{P}[a]}, \nu_{\tilde{P}[a]})$ is a Pythagorean fuzzy BCC-filter of X for all $a \in A$. Let $t \in [0, 1]$ be

such that $U(\mu_{\tilde{P}[a]}, t), L(\nu_{\tilde{P}[a]}, t) \neq \emptyset$. By Theorem 3.4.6, we have $U(\mu_{\tilde{P}[a]}, t)$ and $L(\nu_{\tilde{P}[a]}, t)$ are BCC-filters of X for all $a \in A, t \in [0, 1]$.

Conversely, assume for all $a \in A, t \in [0, 1], U(\mu_{\tilde{P}[a]}, t)$ and $L(\nu_{\tilde{P}[a]}, t)$ are BCC-filters of X if the sets are nonempty. By Theorem 3.4.6, we have $\tilde{P}[a] = (\mu_{\tilde{P}[a]}, \nu_{\tilde{P}[a]})$ is a Pythagorean fuzzy BCC-filter of X for all $a \in A$. Hence, (\tilde{P}, A) is a Pythagorean fuzzy soft BCC-filter of X . \square

Theorem 5.3.6 (\tilde{P}, A) is a Pythagorean fuzzy soft BCC-filter of X if and only if $U^+(\mu_{\tilde{P}[a]}, t)$ and $L^-(\nu_{\tilde{P}[a]}, t)$ are, if the sets are nonempty, BCC-filters for every $a \in A, t \in [0, 1]$.

Proof. Assume (\tilde{P}, A) is a Pythagorean fuzzy soft BCC-filter of X , that is, $\tilde{P}[a] = (\mu_{\tilde{P}[a]}, \nu_{\tilde{P}[a]})$ is a Pythagorean fuzzy BCC-filter of X for all $a \in A$. Let $t \in [0, 1]$ be such that $U^+(\mu_{\tilde{P}[a]}, t), L^-(\nu_{\tilde{P}[a]}, t) \neq \emptyset$. By Theorem 3.4.7, we have $U^+(\mu_{\tilde{P}[a]}, t)$ and $L^-(\nu_{\tilde{P}[a]}, t)$ are BCC-filters of X for all $a \in A, t \in [0, 1]$.

Conversely, assume for all $a \in A, t \in [0, 1], U^+(\mu_{\tilde{P}[a]}, t)$ and $L^-(\nu_{\tilde{P}[a]}, t)$ are BCC-filters of X if the sets are nonempty. By Theorem 3.4.7, we have $\tilde{P}[a] = (\mu_{\tilde{P}[a]}, \nu_{\tilde{P}[a]})$ is a Pythagorean fuzzy BCC-filter of X for all $a \in A$. Hence, (\tilde{P}, A) is a Pythagorean fuzzy soft BCC-filter of X . \square

Theorem 5.3.7 (\tilde{P}, A) is a Pythagorean fuzzy soft implicative BCC-filter of X if and only if $U(\mu_{\tilde{P}[a]}, t)$ and $L(\nu_{\tilde{P}[a]}, t)$ are, if the sets are nonempty, implicative BCC-filters for every $a \in A, t \in [0, 1]$.

Proof. Assume (\tilde{P}, A) is a Pythagorean fuzzy soft implicative BCC-filter of X , that is, $\tilde{P}[a] = (\mu_{\tilde{P}[a]}, \nu_{\tilde{P}[a]})$ is a Pythagorean fuzzy implicative BCC-filter of X for all $a \in A$. Let $t \in [0, 1]$ be such that $U(\mu_{\tilde{P}[a]}, t), L(\nu_{\tilde{P}[a]}, t) \neq \emptyset$. By Theorem 3.4.8, we have $U(\mu_{\tilde{P}[a]}, t)$ and $L(\nu_{\tilde{P}[a]}, t)$ are implicative BCC-filters of X for all $a \in A, t \in [0, 1]$.

Conversely, assume for all $a \in A, t \in [0, 1], U(\mu_{\tilde{P}[a]}, t)$ and $L(\nu_{\tilde{P}[a]}, t)$ are implicative BCC-filters of X if the sets are nonempty. By Theorem 3.4.8, we have $\tilde{P}[a] = (\mu_{\tilde{P}[a]}, \nu_{\tilde{P}[a]})$ is a Pythagorean fuzzy implicative BCC-filter of X for all $a \in A$. Hence, (\tilde{P}, A) is a Pythagorean fuzzy soft implicative BCC-filter of X . \square

Theorem 5.3.8 (\tilde{P}, A) is a Pythagorean fuzzy soft implicative BCC-filter of X if and only if $U^+(\mu_{\tilde{P}[a]}, t)$ and $L^-(\nu_{\tilde{P}[a]}, t)$ are, if the sets are nonempty, implicative BCC-filters for every $a \in A, t \in [0, 1]$.

Proof. Assume (\tilde{P}, A) is a Pythagorean fuzzy soft implicative BCC-filter of X , that is, $\tilde{P}[a] = (\mu_{\tilde{P}[a]}, \nu_{\tilde{P}[a]})$ is a Pythagorean fuzzy implicative BCC-filter of X for all $a \in A$. Let $t \in [0, 1]$ be such that $U^+(\mu_{\tilde{P}[a]}, t), L^-(\nu_{\tilde{P}[a]}, t) \neq \emptyset$. By Theorem 3.4.9, we have $U^+(\mu_{\tilde{P}[a]}, t)$ and $L^-(\nu_{\tilde{P}[a]}, t)$ are implicative BCC-filters of X for all $a \in A, t \in [0, 1]$.

Conversely, assume for all $a \in A, t \in [0, 1], U^+(\mu_{\tilde{P}[a]}, t)$ and $L^-(\nu_{\tilde{P}[a]}, t)$ are implicative BCC-filters of X if the sets are nonempty. By Theorem 3.4.9, we have $\tilde{P}[a] = (\mu_{\tilde{P}[a]}, \nu_{\tilde{P}[a]})$ is a Pythagorean fuzzy implicative BCC-filter of X for all $a \in A$. Hence, (\tilde{P}, A) is a Pythagorean fuzzy soft implicative BCC-filter of X . \square

Theorem 5.3.9 (\tilde{P}, A) is a Pythagorean fuzzy soft comparative BCC-filter of X if and only if $U(\mu_{\tilde{P}[a]}, t)$ and $L(\nu_{\tilde{P}[a]}, t)$ are, if the sets are nonempty, comparative BCC-filters for every $a \in A, t \in [0, 1]$.

Proof. Assume (\tilde{P}, A) is a Pythagorean fuzzy soft comparative BCC-filter of X , that is, $\tilde{P}[a] = (\mu_{\tilde{P}[a]}, \nu_{\tilde{P}[a]})$ is a Pythagorean fuzzy comparative BCC-filter of X for all $a \in A$. Let $t \in [0, 1]$ be such that $U(\mu_{\tilde{P}[a]}, t), L(\nu_{\tilde{P}[a]}, t) \neq \emptyset$. By Theorem 3.4.10, we have $U(\mu_{\tilde{P}[a]}, t)$ and $L(\nu_{\tilde{P}[a]}, t)$ are comparative BCC-filters of X for all $a \in A, t \in [0, 1]$.

Conversely, assume for all $a \in A, t \in [0, 1], U(\mu_{\tilde{P}[a]}, t)$ and $L(\nu_{\tilde{P}[a]}, t)$ are comparative BCC-filters of X if the sets are nonempty. By Theorem 3.4.10, we have $\tilde{P}[a] = (\mu_{\tilde{P}[a]}, \nu_{\tilde{P}[a]})$ is a Pythagorean fuzzy comparative BCC-filter of X for all $a \in A$. Hence, (\tilde{P}, A) is a Pythagorean fuzzy soft comparative BCC-filter of X . \square

Theorem 5.3.10 (\tilde{P}, A) is a Pythagorean fuzzy soft comparative BCC-filter of X if and only if $U^+(\mu_{\tilde{P}[a]}, t)$ and $L^-(\nu_{\tilde{P}[a]}, t)$ are, if the sets are nonempty, comparative BCC-filters for every $a \in A, t \in [0, 1]$.

Proof. Assume (\tilde{P}, A) is a Pythagorean fuzzy soft comparative BCC-filter of X , that is, $\tilde{P}[a] = (\mu_{\tilde{P}[a]}, \nu_{\tilde{P}[a]})$ is a Pythagorean fuzzy comparative BCC-filter of X for all $a \in A$. Let $t \in [0, 1]$ be such that $U^+(\mu_{\tilde{P}[a]}, t), L^-(\nu_{\tilde{P}[a]}, t) \neq \emptyset$. By Theorem 3.4.11, we have $U^+(\mu_{\tilde{P}[a]}, t)$ and $L^-(\nu_{\tilde{P}[a]}, t)$ are comparative BCC-filters of X for all $a \in A, t \in [0, 1]$.

Conversely, assume for all $a \in A, t \in [0, 1], U^+(\mu_{\tilde{P}[a]}, t)$ and $L^-(\nu_{\tilde{P}[a]}, t)$ are comparative BCC-filters of X if the sets are nonempty. By Theorem 3.4.11, we have $\tilde{P}[a] = (\mu_{\tilde{P}[a]}, \nu_{\tilde{P}[a]})$ is a Pythagorean fuzzy comparative BCC-filter of X for all $a \in A$. Hence, (\tilde{P}, A) is a Pythagorean fuzzy soft comparative BCC-filter of X . \square

Theorem 5.3.11 (\tilde{P}, A) is a Pythagorean fuzzy soft shift BCC-filter of X if and only if $U(\mu_{\tilde{P}[a]}, t)$ and $L(\nu_{\tilde{P}[a]}, t)$ are, if the sets are nonempty, shift BCC-filters for every $a \in A, t \in [0, 1]$.

Proof. Assume (\tilde{P}, A) is a Pythagorean fuzzy soft shift BCC-filter of X , that is, $\tilde{P}[a] = (\mu_{\tilde{P}[a]}, \nu_{\tilde{P}[a]})$ is a Pythagorean fuzzy shift BCC-filter of X for all $a \in A$. Let $t \in [0, 1]$ be such that $U(\mu_{\tilde{P}[a]}, t), L(\nu_{\tilde{P}[a]}, t) \neq \emptyset$. By Theorem 3.4.12, we have $U(\mu_{\tilde{P}[a]}, t)$ and $L(\nu_{\tilde{P}[a]}, t)$ are shift BCC-filters of X for all $a \in A, t \in [0, 1]$.

Conversely, assume for all $a \in A, t \in [0, 1], U(\mu_{\tilde{P}[a]}, t)$ and $L(\nu_{\tilde{P}[a]}, t)$ are shift BCC-filters of X if the sets are nonempty. By Theorem 3.4.12, we have $\tilde{P}[a] = (\mu_{\tilde{P}[a]}, \nu_{\tilde{P}[a]})$ is a Pythagorean fuzzy shift BCC-filter of X for all $a \in A$. Hence, (\tilde{P}, A) is a Pythagorean fuzzy soft shift BCC-filter of X . \square

Theorem 5.3.12 (\tilde{P}, A) is a Pythagorean fuzzy soft shift BCC-filter of X if and only if $U^+(\mu_{\tilde{P}[a]}, t)$ and $L^-(\nu_{\tilde{P}[a]}, t)$ are, if the sets are nonempty, shift BCC-filters for every $a \in A, t \in [0, 1]$.

Proof. Assume (\tilde{P}, A) is a Pythagorean fuzzy soft shift BCC-filter of X , that is, $\tilde{P}[a] = (\mu_{\tilde{P}[a]}, \nu_{\tilde{P}[a]})$ is a Pythagorean fuzzy shift BCC-filter of X for all $a \in A$. Let $t \in [0, 1]$ be such that $U^+(\mu_{\tilde{P}[a]}, t), L^-(\nu_{\tilde{P}[a]}, t) \neq \emptyset$. By Theorem 3.4.13, we have $U^+(\mu_{\tilde{P}[a]}, t)$ and $L^-(\nu_{\tilde{P}[a]}, t)$ are shift BCC-filters of X for all $a \in A, t \in [0, 1]$.

Conversely, assume for all $a \in A, t \in [0, 1], U^+(\mu_{\tilde{P}[a]}, t)$ and $L^-(\nu_{\tilde{P}[a]}, t)$ are shift BCC-filters of X if the sets are nonempty. By Theorem 3.4.13, we have $\tilde{P}[a] = (\mu_{\tilde{P}[a]}, \nu_{\tilde{P}[a]})$ is a Pythagorean fuzzy shift BCC-filter of X for all $a \in A$. Hence, (\tilde{P}, A) is a Pythagorean fuzzy soft shift BCC-filter of X . \square

Theorem 5.3.13 (\tilde{P}, A) is a Pythagorean fuzzy soft BCC-ideal of X if and only if $U(\mu_{\tilde{P}[a]}, t)$ and $L(\nu_{\tilde{P}[a]}, t)$ are, if the sets are nonempty, BCC-ideals for every $a \in A, t \in [0, 1]$.

Proof. Assume (\tilde{P}, A) is a Pythagorean fuzzy soft BCC-ideal of X , that is, $\tilde{P}[a] = (\mu_{\tilde{P}[a]}, \nu_{\tilde{P}[a]})$ is a Pythagorean fuzzy BCC-ideal of X for all $a \in A$. Let $t \in [0, 1]$ be such that $U(\mu_{\tilde{P}[a]}, t), L(\nu_{\tilde{P}[a]}, t) \neq \emptyset$. By Theorem 3.4.14, we have $U(\mu_{\tilde{P}[a]}, t)$ and $L(\nu_{\tilde{P}[a]}, t)$ are BCC-ideals of X for all $a \in A, t \in [0, 1]$.

Conversely, assume for all $a \in A, t \in [0, 1], U(\mu_{\tilde{P}[a]}, t)$ and $L(\nu_{\tilde{P}[a]}, t)$ are BCC-ideals of X if the sets are nonempty. By Theorem 3.4.14, we have $\tilde{P}[a] = (\mu_{\tilde{P}[a]}, \nu_{\tilde{P}[a]})$ is a Pythagorean fuzzy BCC-ideal of X for all $a \in A$. Hence,

(\tilde{P}, A) is a Pythagorean fuzzy soft BCC-ideal of X . \square

Theorem 5.3.14 (\tilde{P}, A) is a Pythagorean fuzzy soft BCC-ideal of X if and only if $U^+(\mu_{\tilde{P}[a]}, t)$ and $L^-(\nu_{\tilde{P}[a]}, t)$ are, if the sets are nonempty, BCC-ideals for every $a \in A, t \in [0, 1]$.

Proof. Assume (\tilde{P}, A) is a Pythagorean fuzzy soft BCC-ideal of X , that is, $\tilde{P}[a] = (\mu_{\tilde{P}[a]}, \nu_{\tilde{P}[a]})$ is a Pythagorean fuzzy BCC-ideal of X for all $a \in A$. Let $t \in [0, 1]$ be such that $U^+(\mu_{\tilde{P}[a]}, t), L^-(\nu_{\tilde{P}[a]}, t) \neq \emptyset$. By Theorem 3.4.15, we have $U^+(\mu_{\tilde{P}[a]}, t)$ and $L^-(\nu_{\tilde{P}[a]}, t)$ are BCC-ideals of X for all $a \in A, t \in [0, 1]$.

Conversely, assume for all $a \in A, t \in [0, 1], U^+(\mu_{\tilde{P}[a]}, t)$ and $L^-(\nu_{\tilde{P}[a]}, t)$ are BCC-ideals of X if the sets are nonempty. By Theorem 3.4.15, we have $\tilde{P}[a] = (\mu_{\tilde{P}[a]}, \nu_{\tilde{P}[a]})$ is a Pythagorean fuzzy BCC-ideal of X for all $a \in A$. Hence, (\tilde{P}, A) is a Pythagorean fuzzy soft BCC-ideal of X . \square

Theorem 5.3.15 (\tilde{P}, A) is a Pythagorean fuzzy soft strong BCC-ideal of X if and only if $U(\mu_{\tilde{P}[a]}, t)$ and $L(\nu_{\tilde{P}[a]}, t)$ are, if the sets are nonempty, strong BCC-ideals for every $a \in A, t \in [0, 1]$.

Proof. Assume (\tilde{P}, A) is a Pythagorean fuzzy soft strong BCC-ideal of X , that is, $\tilde{P}[a] = (\mu_{\tilde{P}[a]}, \nu_{\tilde{P}[a]})$ is a Pythagorean fuzzy strong BCC-ideal of X for all $a \in A$. Let $t \in [0, 1]$ be such that $U(\mu_{\tilde{P}[a]}, t), L(\nu_{\tilde{P}[a]}, t) \neq \emptyset$. By Theorem 3.4.16, we have $U(\mu_{\tilde{P}[a]}, t)$ and $L(\nu_{\tilde{P}[a]}, t)$ are strong BCC-ideals of X for all $a \in A, t \in [0, 1]$.

Conversely, assume for all $a \in A, t \in [0, 1], U(\mu_{\tilde{P}[a]}, t)$ and $L(\nu_{\tilde{P}[a]}, t)$ are strong BCC-ideals of X if the sets are nonempty. By Theorem 3.4.16, we have $\tilde{P}[a] = (\mu_{\tilde{P}[a]}, \nu_{\tilde{P}[a]})$ is a Pythagorean fuzzy strong BCC-ideal of X for all $a \in A$. Hence, (\tilde{P}, A) is a Pythagorean fuzzy soft strong BCC-ideal of X . \square

Theorem 5.3.16 (\tilde{P}, A) is a Pythagorean fuzzy soft strong BCC-ideal of X if and only if $U^+(\mu_{\tilde{P}[a]}, t)$ and $L^-(\nu_{\tilde{P}[a]}, t)$ are, if the sets are nonempty, strong BCC-

ideals for every $a \in A, t \in [0, 1]$.

Proof. Assume (\tilde{P}, A) is a Pythagorean fuzzy soft strong BCC-ideal of X , that is, $\tilde{P}[a] = (\mu_{\tilde{P}[a]}, \nu_{\tilde{P}[a]})$ is a Pythagorean fuzzy strong BCC-ideal of X for all $a \in A$. Let $t \in [0, 1]$ be such that $U^+(\mu_{\tilde{P}[a]}, t), L^-(\nu_{\tilde{P}[a]}, t) \neq \emptyset$. By Theorem 3.4.17, we have $U^+(\mu_{\tilde{P}[a]}, t)$ and $L^-(\nu_{\tilde{P}[a]}, t)$ are strong BCC-ideals of X for all $a \in A, t \in [0, 1]$.

Conversely, assume for all $a \in A, t \in [0, 1], U^+(\mu_{\tilde{P}[a]}, t)$ and $L^-(\nu_{\tilde{P}[a]}, t)$ are strong BCC-ideals of X if the sets are nonempty. By Theorem 3.4.17, we have $\tilde{P}[a] = (\mu_{\tilde{P}[a]}, \nu_{\tilde{P}[a]})$ is a Pythagorean fuzzy strong BCC-ideal of X for all $a \in A$. Hence, (\tilde{P}, A) is a Pythagorean fuzzy soft strong BCC-ideal of X . \square

Theorem 5.3.17 (\tilde{P}, A) is a Pythagorean fuzzy soft strong BCC-ideal of X if and only if $E(\mu_{\tilde{P}[a]}, \mu_{\tilde{P}[a]}(0))$ and $E(\nu_{\tilde{P}[a]}, \nu_{\tilde{P}[a]}(0))$ are strong BCC-ideals of X .

Proof. Assume (\tilde{P}, A) is a Pythagorean fuzzy soft strong BCC-ideal of X , that is, $\tilde{P}[a] = (\mu_{\tilde{P}[a]}, \nu_{\tilde{P}[a]})$ is a Pythagorean fuzzy strong BCC-ideal of X for all $a \in A$. By Theorem 3.4.18, we have $E(\mu_{\tilde{P}[a]}, \mu_{\tilde{P}[a]}(0))$ and $E(\nu_{\tilde{P}[a]}, \nu_{\tilde{P}[a]}(0))$ are strong BCC-ideals of X .

Conversely, assume for all $a \in A, E(\mu_{\tilde{P}[a]}, \mu_{\tilde{P}[a]}(0))$ and $E(\nu_{\tilde{P}[a]}, \nu_{\tilde{P}[a]}(0))$ are strong BCC-ideals of X . By Theorem 3.4.18, we have $\tilde{P}[a] = (\mu_{\tilde{P}[a]}, \nu_{\tilde{P}[a]})$ is a Pythagorean fuzzy strong BCC-ideal of X for all $a \in A$. Hence, (\tilde{P}, A) is a Pythagorean fuzzy soft strong BCC-ideal of X . \square

CHAPTER VI

CONCLUSIONS

The following results are all the main theorems of this dissertation.

1. Let F be a fuzzy set in X . Then the following statements hold:
 - (1) $(f_F, f_{\bar{F}})$ is a Pythagorean fuzzy set in X and
 - (2) F is a fuzzy BCC-subalgebra (resp., fuzzy near BCC-filter, fuzzy BCC-filter, fuzzy implicative BCC-filter, fuzzy comparative BCC-filter, fuzzy shift BCC-filter, fuzzy BCC-ideal, and fuzzy strong BCC-ideal) of X if and only if $(f_F, f_{\bar{F}})$ is a Pythagorean fuzzy BCC-subalgebra (resp., Pythagorean fuzzy near BCC-filter, Pythagorean fuzzy BCC-filter, Pythagorean fuzzy implicative BCC-filter, Pythagorean fuzzy comparative BCC-filter, Pythagorean fuzzy shift BCC-filter, Pythagorean fuzzy BCC-ideal, and Pythagorean fuzzy strong BCC-ideal) of X .
2. Let ρ be an equivalence relation on a nonempty set X and $P = (\mu_P, \nu_P)$ a Pythagorean fuzzy set in X . Then $\rho^+(P)$ and $\rho^-(P)$ are a Pythagorean fuzzy set in X .
3. Let ρ be a congruence relation on a BCC-algebra $X = (X, \cdot, 0)$ and $P = (\mu_P, \nu_P)$ a Pythagorean fuzzy set in X . Then the following statements hold:
 - (1) if P is a Pythagorean fuzzy BCC-subalgebra (resp., Pythagorean fuzzy near BCC-filter) of X and ρ is complete, then $\rho^-(P)$ is a Pythagorean fuzzy BCC-subalgebra (resp., Pythagorean fuzzy near BCC-filter) of X ,
 - (2) if P is a Pythagorean fuzzy BCC-filter of X and $(0)_\rho = \{0\}$, then $\rho^-(P)$ is a Pythagorean fuzzy BCC-filter of X ,

- (3) if P is a Pythagorean fuzzy implicative BCC-filter (resp., Pythagorean fuzzy comparative BCC-filter, Pythagorean fuzzy shift BCC-filter, and Pythagorean fuzzy BCC-ideal) of X , $(0)_\rho = \{0\}$, and ρ is complete, then $\rho^-(P)$ is a Pythagorean fuzzy implicative BCC-filter (resp., Pythagorean fuzzy comparative BCC-filter, Pythagorean fuzzy shift BCC-filter, and Pythagorean fuzzy BCC-ideal) of X , and
- (4) if P is a Pythagorean fuzzy strong BCC-ideal of X , then $\rho^-(P)$ is a Pythagorean fuzzy strong BCC-ideal of X .
4. Let ρ be an congruence relation on a BCC-algebra $X = (X, \cdot, 0)$ and $P = (\mu_P, \nu_P)$ a Pythagorean fuzzy set in X . If P is a Pythagorean fuzzy BCC-subalgebra (resp., Pythagorean fuzzy near BCC-filter and Pythagorean fuzzy strong BCC-ideal) of X , then $\rho^+(P)$ is a Pythagorean fuzzy BCC-subalgebra (resp., Pythagorean fuzzy near BCC-filter and Pythagorean fuzzy strong BCC-ideal) of X .
5. P is a Pythagorean fuzzy BCC-subalgebra (resp., Pythagorean fuzzy near BCC-filter, Pythagorean fuzzy BCC-filter, Pythagorean fuzzy implicative BCC-filter, Pythagorean fuzzy comparative BCC-filter, Pythagorean fuzzy shift BCC-filter, Pythagorean fuzzy BCC-ideal, and Pythagorean fuzzy strong BCC-ideal) of X if and only if $U(\mu_P, t)$ and $L(\nu_P, t)$ are, if the sets are nonempty, BCC-subalgebras (resp., near BCC-filters, BCC-filters, implicative BCC-filters, comparative BCC-filters, shift BCC-filters, BCC-ideals, and strong BCC-ideals) of X for every $t \in [0, 1]$.
6. P is a Pythagorean fuzzy BCC-subalgebra (resp., Pythagorean fuzzy near BCC-filter, Pythagorean fuzzy BCC-filter, Pythagorean fuzzy implicative BCC-filter, Pythagorean fuzzy comparative BCC-filter, Pythagorean fuzzy shift BCC-filter, Pythagorean fuzzy BCC-ideal, and Pythagorean fuzzy strong BCC-ideal) of X if and only if $U^+(\mu_P, t)$ and $L^-(\nu_P, t)$ are, if the

sets are nonempty, BCC-subalgebras (resp., near BCC-filters, BCC-filters, implicative BCC-filters, comparative BCC-filters, shift BCC-filters, BCC-ideals, and strong BCC-ideals) of X for every $t \in [0, 1]$.

7. P is a Pythagorean fuzzy strong BCC-ideal of X if and only if $E(\mu_P, \mu_P(0))$ and $E(\nu_P, \nu_P(0))$ are strong BCC-ideals of X .
8. The intersection of any nonempty family of Pythagorean fuzzy BCC-subalgebras (resp., Pythagorean fuzzy near BCC-filters, Pythagorean fuzzy BCC-filters, Pythagorean fuzzy implicative BCC-filters, Pythagorean fuzzy comparative BCC-filters, Pythagorean fuzzy shift BCC-filters, Pythagorean fuzzy BCC-ideals, and Pythagorean fuzzy strong BCC-ideals) of X is also a Pythagorean fuzzy BCC-subalgebra (resp., Pythagorean fuzzy near BCC-filter, Pythagorean fuzzy BCC-filter, Pythagorean fuzzy implicative BCC-filter, Pythagorean fuzzy comparative BCC-filter, Pythagorean fuzzy shift BCC-filter, Pythagorean fuzzy BCC-ideal, and Pythagorean fuzzy strong BCC-ideal).
9. The union of any nonempty family of Pythagorean fuzzy near BCC-filters (resp., Pythagorean fuzzy strong BCC-ideals) of X is also a Pythagorean fuzzy near BCC-filter (resp., Pythagorean fuzzy strong BCC-ideal).
10. Let ρ be an equivalence relation (congruence relation) on X and $P = (\mu_P, \nu_P)$ a Pythagorean fuzzy sets in X . If P is a Pythagorean fuzzy strong BCC-ideal of X , then P is a rough Pythagorean fuzzy strong BCC-ideal of X .
11. Let ρ be a congruence relation on X . Then P is a rough Pythagorean fuzzy BCC-subalgebra (resp., rough Pythagorean fuzzy near BCC-filter, rough Pythagorean fuzzy BCC-filter, rough Pythagorean fuzzy implicative BCC-filter, rough Pythagorean fuzzy comparative BCC-filter, rough

Pythagorean fuzzy shift BCC-filter, rough Pythagorean fuzzy BCC-ideal, and rough Pythagorean fuzzy strong BCC-ideal) of X if and only if $U(\mu_P, t)$ and $L(\nu_P, t)$ are, if the sets are nonempty, rough BCC-subalgebras (resp., rough near BCC-filters, rough BCC-filters, rough implicative BCC-filters, rough comparative BCC-filters, rough shift BCC-filters, rough BCC-ideals, and rough strong BCC-ideals) of X for every $t \in [0, 1]$.

12. Let ρ be a congruence relation on X . Then P is a rough Pythagorean fuzzy BCC-subalgebra (resp., rough Pythagorean fuzzy near BCC-filter, rough Pythagorean fuzzy BCC-filter, rough Pythagorean fuzzy implicative BCC-filter, rough Pythagorean fuzzy comparative BCC-filter, rough Pythagorean fuzzy shift BCC-filter, rough Pythagorean fuzzy BCC-ideal, and rough Pythagorean fuzzy strong BCC-ideal) of X if and only if $U^+(\mu_P, t)$ and $L^-(\nu_P, t)$ are, if the sets are nonempty, rough BCC-subalgebras (resp., rough near BCC-filters, rough BCC-filters, rough implicative BCC-filters, rough comparative BCC-filters, rough shift BCC-filters, rough BCC-ideals, and rough strong BCC-ideals) of X for every $t \in [0, 1]$.
13. The extended intersection of two Pythagorean fuzzy soft BCC-subalgebras (resp., Pythagorean fuzzy soft near BCC-filters, Pythagorean fuzzy soft BCC-filters, Pythagorean fuzzy soft implicative BCC-filters, Pythagorean fuzzy soft comparative BCC-filters, Pythagorean fuzzy soft shift BCC-filters, Pythagorean fuzzy soft BCC-ideals, and Pythagorean fuzzy soft strong BCC-ideals) of X is also a Pythagorean fuzzy soft BCC-subalgebra (resp., Pythagorean fuzzy soft near BCC-filter, Pythagorean fuzzy soft BCC-filter, Pythagorean fuzzy soft implicative BCC-filter, Pythagorean fuzzy soft comparative BCC-filter, Pythagorean fuzzy soft shift BCC-filter, Pythagorean fuzzy soft BCC-ideal, and Pythagorean fuzzy soft strong BCC-ideal). Moreover, the intersection of two Pythagorean fuzzy soft BCC-

subalgebras (resp., Pythagorean fuzzy soft near BCC-filters, Pythagorean fuzzy soft BCC-filters, Pythagorean fuzzy soft implicative BCC-filters, Pythagorean fuzzy soft comparative BCC-filters, Pythagorean fuzzy soft shift BCC-filters, Pythagorean fuzzy soft BCC-ideals, and Pythagorean fuzzy soft strong BCC-ideals) of X is also a Pythagorean fuzzy soft BCC-subalgebra (resp., Pythagorean fuzzy soft near BCC-filter, Pythagorean fuzzy soft BCC-filter, Pythagorean fuzzy soft implicative BCC-filter, Pythagorean fuzzy soft comparative BCC-filter, Pythagorean fuzzy soft shift BCC-filter, Pythagorean fuzzy soft BCC-ideal, and Pythagorean fuzzy soft strong BCC-ideal).

14. The union of two Pythagorean fuzzy soft BCC-subalgebras (resp., Pythagorean fuzzy soft BCC-filters, Pythagorean fuzzy soft implicative BCC-filters, Pythagorean fuzzy soft comparative BCC-filters, Pythagorean fuzzy soft shift BCC-filters, and Pythagorean fuzzy soft BCC-ideals) of X is also a Pythagorean fuzzy soft BCC-subalgebra (resp., Pythagorean fuzzy soft BCC-filter, Pythagorean fuzzy soft implicative BCC-filter, Pythagorean fuzzy soft comparative BCC-filter, Pythagorean fuzzy soft shift BCC-filter, and Pythagorean fuzzy soft BCC-ideal) if sets of statistics of two Pythagorean fuzzy soft BCC-subalgebras (resp., Pythagorean fuzzy soft BCC-filters, Pythagorean fuzzy soft implicative BCC-filters, Pythagorean fuzzy soft comparative BCC-filters, Pythagorean fuzzy soft shift BCC-filters, and Pythagorean fuzzy soft BCC-ideals) are disjoint.
15. The union of two Pythagorean fuzzy soft near BCC-filters (resp., Pythagorean fuzzy soft strong BCC-ideals) of X is also a Pythagorean fuzzy soft near BCC-filter (resp., Pythagorean fuzzy soft strong BCC-ideal). Moreover, the restricted union of two Pythagorean fuzzy soft near BCC-filters (resp., Pythagorean fuzzy soft strong BCC-ideals) of X is also a Pythagorean fuzzy

soft near BCC-filter (resp., Pythagorean fuzzy soft strong BCC-ideal).

16. (\tilde{P}, A) is a Pythagorean fuzzy soft BCC-subalgebra (resp., Pythagorean fuzzy soft near BCC-filter, Pythagorean fuzzy soft BCC-filter, Pythagorean fuzzy soft implicative BCC-filter, Pythagorean fuzzy soft comparative BCC-filter, Pythagorean fuzzy soft shift BCC-filter, Pythagorean fuzzy soft BCC-ideal, and Pythagorean fuzzy soft strong BCC-ideal) of X if and only if $U(\mu_{\tilde{P}[a]}, t)$ and $L(\nu_{\tilde{P}[a]}, t)$ are, if the sets are nonempty, BCC-subalgebras (resp., near BCC-filters, BCC-filters, implicative BCC-filters, comparative BCC-filters, shift BCC-filters, BCC-ideals, and strong BCC-ideals) for every $a \in A, t \in [0, 1]$.
17. (\tilde{P}, A) is a Pythagorean fuzzy soft BCC-subalgebra (resp., Pythagorean fuzzy soft near BCC-filter, Pythagorean fuzzy soft BCC-filter, Pythagorean fuzzy soft implicative BCC-filter, Pythagorean fuzzy soft comparative BCC-filter, Pythagorean fuzzy soft shift BCC-filter, Pythagorean fuzzy soft BCC-ideal, and Pythagorean fuzzy soft strong BCC-ideal) of X if and only if $U^+(\mu_{\tilde{P}[a]}, t)$ and $L^-(\nu_{\tilde{P}[a]}, t)$ are, if the sets are nonempty, BCC-subalgebras (resp., near BCC-filters, BCC-filters, implicative BCC-filters, comparative BCC-filters, shift BCC-filters, BCC-ideals, and strong BCC-ideals) for every $a \in A, t \in [0, 1]$.
18. (\tilde{P}, A) is a Pythagorean fuzzy soft strong BCC-ideal of X if and only if $E(\mu_{\tilde{P}[a]}, \mu_{\tilde{P}[a]}(0))$ and $E(\nu_{\tilde{P}[a]}, \nu_{\tilde{P}[a]}(0))$ are strong BCC-ideals of X .

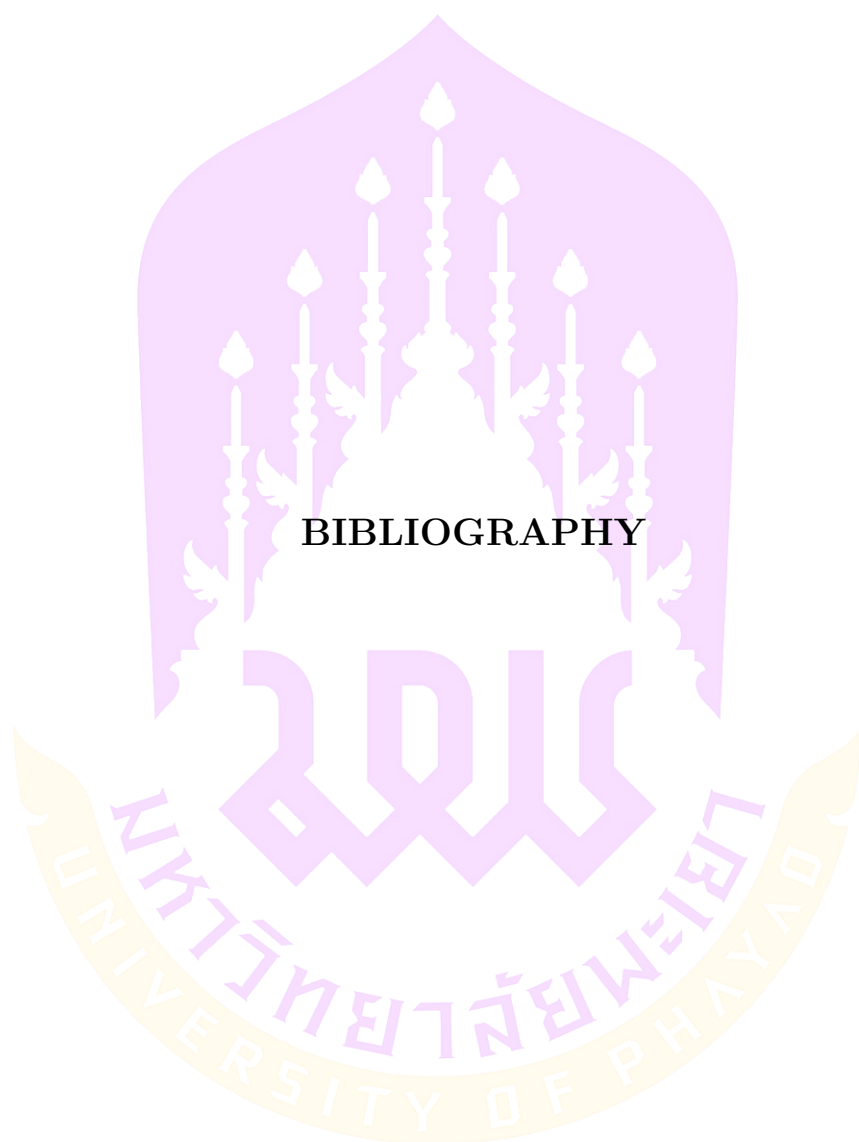

BIBLIOGRAPHY

BIBLIOGRAPHY

- [1] Ahn, S. S. and Kim, C. (2016). Rough set theory applied to fuzzy filters in BE-algebras. **Commun. Korean Math. Soc.**, 31(3), 451–460.
- [2] Ahn, S. S. and Ko, J. M. (2018). Rough fuzzy ideals in BCK/BCI-algebras. **J. Comput. Anal. Appl.**, 25(1), 75–84.
- [3] Ansari, M. A., Haidar, A., and Koam, A. N. A. (2018). On a graph associated to UP-algebras. **Math. Comput. Appl.**, 23(4), Article number: 61.
- [4] Ansari, M. A., Koam, A. N. A., and Haider, A. (2019). Rough set theory applied to UP-algebras. **Ital. J. Pure Appl. Math.**, 42, 388–402.
- [5] Atanassov, K. T. (1986). Intuitionistic fuzzy sets. **Fuzzy Sets Syst.**, 20, 87–96.
- [6] Chen, L. and Wang, F. (2008). On rough ideals and rough fuzzy ideals of BCI-algebras. **Fifth international conference on fuzzy systems and knowledge discovery**, 5, 281–284.
- [7] Chinram, R. and Panityakul, T. (2020). Rough Pythagorean fuzzy ideals in ternary semigroups. **J. Math. Computer Sci.**, 20, 303–312.
- [8] Dokkhamdang, N., Kesorn, A., and Iampan, A. (2018). Generalized fuzzy sets in UP-algebras. **Ann. Fuzzy Math. Inform.**, 16(2), 171–190.
- [9] Dudek, W. A., Jun, Y. B., and Kim, H. S. (2002). Rough set theory applied to BCI-algebras. **Quasigroups Relat. Syst.**, 9, 45–54.
- [10] Guntasow, T., Sajak, S., Jomkham, A., and Iampan, A. (2017). Fuzzy translations of a fuzzy set in UP-algebras. **J. Indones. Math. Soc.**, 23(2), 1–19.

- [11] Hussain, A., Mahmood, T., and Ali, M. I. (2019). Rough Pythagorean fuzzy ideals in semigroups. **Comput. Appl. Math.**, 38, Article number: 67.
- [12] Iampan, A. (2017). A new branch of the logical algebra: UP-algebras. **J. Algebra Relat. Top.**, 5(1), 35–54.
- [13] Iampan, A. (2018). Introducing fully UP-semigroups. **Discuss. Math., Gen. Algebra Appl.**, 38(2), 297–306.
- [14] Iampan, A. (2021). Multipliers and near UP-filters of UP-algebras. **J. Discrete Math. Sci. Cryptography**, 24(3), 667–680.
- [15] Iampan, A., Satirad, A., and Songsaeng, M. (2020). A note on UP-hyperalgebras. **J. Algebr. Hyperstruct. Log. Algebr.**, 1(2), 77–95.
- [16] Iampan, A., Songsaeng, M., and Muhiuddin, G. (2020). Fuzzy duplex UP-algebras. **Eur. J. Pure Appl. Math.**, 13(3), 459–471.
- [17] Imai, Y. and Iséki, K. (1966). On axiom systems of propositional calculi, XIV. **Proc. Japan Acad.**, 42(1), 19–22.
- [18] Iséki, K. (1966). An algebra related with a propositional calculus. **Proc. Japan Acad.**, 42(1), 26–29.
- [19] Jansi, R. and Mohana, K. (2019). Bipolar Pythagorean fuzzy A-ideals of BCI-algebra. **Int. J. Innovat. Res. Sci. Eng. Tech.**, 6(5), 102–109.
- [20] Jun, Y. B. (2002). Roughness of ideals in BCK-algebras. **Sci. Math. Japon.**, 7, 115–119.

- [21] Jun, Y. B., Brundha, B., Rajesh, N., and Bandaru, R. K. (2022). $(3, 2)$ -fuzzy UP-subalgebras and $(3, 2)$ -fuzzy UP-filters. **J. Mahani Math. Res. Cent.**, 11, 1–14.
- [22] Jun, Y. B. and Iampan, A. (2019). Comparative and allied UP-filters. **Lobachevskii J. Math.**, 40(1), 60–66.
- [23] Jun, Y. B. and Iampan, A. (2019). Implicative UP-filters. **Afr. Mat.**, 30(7–8), 1093–1101.
- [24] Jun, Y. B. and Iampan, A. (2019). Shift UP-filters and decompositions of UP-filters in UP-algebras. **Missouri J. Math. Sci.**, 31(1), 36–45.
- [25] Kim, H. S. and Kim, Y. H. (2007). On BE-algebras. **Math. Japon.**, 66(1), 113–116.
- [26] Klinseesook, T., Bukok, S., and Iampan, A. (2020). Rough set theory applied to UP-algebras. **J. Inf. Optim. Sci.**, 41(3), 705–722.
- [27] Komori, Y. (1984). The class of BCC-algebras is not a variety. **Math. Japon.**, 29, 391–394.
- [28] Maji, P. K., Biswas, R., and Roy, A. R. (2001). Fuzzy soft sets. **J. Fuzzy Math.**, 9(3), 589–602.
- [29] Molodtsov, D. (1999). Soft set theory—first results. **Comput. Math. Appl.**, 37, 19–31.
- [30] Moradiana, R., Shoar, S. K., and Radfar, A. (2016). Rough sets induced by fuzzy ideals in BCK-algebras. **J. Intell. Fuzzy Syst.**, 30, 2397–2404.
- [31] Mostafa, S. M., Naby, M. A. A., and Yousef, M. M. M. (2011). Fuzzy ideals of KU-algebras. **Int. Math. Forum**, 63(6), 3139–3149.
- [32] Neggers, J. and Kim, H. S. (2002). On B-algebras. **Mat. Vesnik**, 54, 21–29.

- [33] Pawlak, Z. (1982). Rough sets. **Int. J. Inform. Comp. Sci.**, 11, 341–356.
- [34] Peng, X., Yang, Y., Song, J., and Jiang, Y. (2015). Pythagorean fuzzy soft set and its application. **Comput. Eng.**, 41(7), 224–229.
- [35] Prabpayak, C. and Leerawat, U. (2009). On ideals and congruences in KU-algebras. **Sci. Magna**, 5(1), 54–57.
- [36] Rehman, A., Abdullah, S., Aslam, M., and Kamran, M. S. (2013). A study on fuzzy soft set and its operations. **Ann. Fuzzy Math. Inform.**, 6(2), 339–362.
- [37] Satirad, A., Chinram, R., and Iampan, A. (2020). Four new concepts of extensions of KU/UP-algebras. **Missouri J. Math. Sci.**, 32(2), 138–157.
- [38] Satirad, A. and Iampan, A. (2019). Fuzzy sets in fully UP-semigroups. **Ital. J. Pure Appl. Math.**, 42, 539–558.
- [39] Satirad, A. and Iampan, A. (2019). Fuzzy soft sets over fully UP-semigroups. **Eur. J. Pure Appl. Math.**, 12(2), 294–331.
- [40] Satirad, A. and Iampan, A. (2019). Properties of operations for fuzzy soft sets over fully UP-semigroups. **Int. J. Anal. Appl.**, 17(5), 821–837.
- [41] Satirad, A. and Iampan, A. (2019). Topological UP-algebras. **Discuss. Math., Gen. Algebra Appl.**, 39(2), 231–250.
- [42] Satirad, A., Mosrijai, P., and Iampan, A. (2019). Formulas for finding UP-algebras. **Int. J. Math. Comput. Sci.**, 14(2), 403–409.
- [43] Satirad, A., Mosrijai, P., and Iampan, A. (2019). Generalized power UP-algebras. **Int. J. Math. Comput. Sci.**, 14(1), 17–25.

- [44] Satirad, A., Mosrijai, P., Kamti, W., and Iampan, A. (2017). Level subsets of a hesitant fuzzy set on UP-algebras. **Ann. Fuzzy Math. Inform.**, 14(3), 279–302.
- [45] Senapati, T., Jun, Y. B., and Shum, K. P. (2018). Cubic set structure applied in UP-algebras. **Discrete Math. Algorithms Appl.**, 10(4), Article number: 1850049.
- [46] Senapati, T., Muhiuddin, G., and Shum, K. P. (2017). Representation of UP-algebras in interval-valued intuitionistic fuzzy environment. **Ital. J. Pure Appl. Math.**, 38, 497–517.
- [47] Somjanta, J., Thuekaew, N., Kumpeangkeaw, P., and Iampan, A. (2016). Fuzzy sets in UP-algebras. **Ann. Fuzzy Math. Inform.**, 12(6), 739–756.
- [48] Torra, V. (2010). Hesitant fuzzy sets. **Int. J. Intell. Syst.**, 25, 529–539.
- [49] Torra, V. and Narukawa, Y. (2009). On hesitant fuzzy sets and decision. **18th IEEE Int. Conf. Fuzzy Syst.**, 1378–1382.
- [50] Touqeer, M. (2020). Intuitionistic fuzzy soft set theoretic approaches to α -ideals in BCI-algebras. **Fuzzy inf. Eng.**, 12(2), 150–180.
- [51] Yager, R. R. (2013). Pythagorean fuzzy subsets. **2013 Jt. IFSA World Congr. NAFIPS Annu. Meet. (IFSA/NAFIPS)**, Edmomton, Canada, 57–61.
- [52] Yager, R. R. and Abbasov, A. M. (2013). Pythagorean member grades, complex numbers, and decision making. **Int. J. Intell. Syst.**, 28, 436–452.
- [53] Zadeh, L. A. (1965). Fuzzy sets. **Inf. Cont.**, 8(3), 338–353.



BIOGRAPHY

มหาวิทยาลัยพะเยา
UNIVERSITY OF PHAYAO

BIOGRAPHY

Name Surname Akarachai Satirad
Date of Birth January 4, 1995
Place of Birth Phayao Province, Thailand
Address 111 Moo 10, Fai Kwang Subdistrict,
Chiang Kham District, Phayao Province 56110,
Thailand
E-mail akarachai.sa@gmail.com

Education Background

2023 Ph.D. (Mathematics), University of Phayao,
Phayao, Thailand
2019 M.Sc. (Mathematics), University of Phayao,
Phayao, Thailand
2016 B.Sc. (Mathematics), University of Phayao,
Phayao, Thailand

Publications

Articles

1. **Satirad, A.**, Chinram, R., and Iampan, A. (2021). Pythagorean fuzzy sets in UP-algebras and approximations. **AIMS Math.**, 6(6), 6002–6032
2. **Satirad, A.**, Chinram, R., Julatha, P., and Iampan, A. (2022). Rough Pythagorean fuzzy sets in UP-algebras. **Eur. J. Pure Appl. Math.**, 15(1), 169–198
3. **Satirad, A.**, Chinram, R., Julatha, P., Prasertpong, R., and Iampan, A. (2023). New types of rough Pythagorean fuzzy UP-filters of UP-algebras. **J. Math. Comput. Sci.**, 28(3),

236–257

4. **Satirad, A.**, Chinram, R., Julatha, P., and Iampan, A. (2023). Pythagorean fuzzy implicative/comparative/shift UP-filters of UP-algebras with approximations. **Int. J. Fuzzy Logic Intell. Syst.**, 23(1), 56–78
5. **Satirad, A.**, Prasertpong, R., Julatha, P., Chinram, R., and Iampan, A. (2023). Pythagorean fuzzy soft sets over UP-algebras. Manuscript accepted for publication in **J. Appl. Math. Inf.**
6. **Satirad, A.**, Prasertpong, R., Julatha, P., Chinram, R., Singavananda, P., and Iampan, A. (2023). Three new concepts of Pythagorean fuzzy soft UP (BCC)-filters. Manuscript accepted for publication in **J. Math. Comput. Sci.**

